



User Manual

Fly

Revision 2.0

January, 2024

© Tempest Lighting, Inc.



Table of Contents

Approvals – Europe	4
Approvals – China	5
Introduction	6
IMPORTANT: Safety Advisories	6
Supported Projectors	7
Clearances	8
Air Clearance	8
Snow Clearance	8
Assembling the Fly Enclosure	9
Install Auxiliary Equipment	10
Installing the Projector	11
Fitting the Projector Tray	12
Connecting the Projector	12
Fit the Enclosure Top Cover	13
Fit the Side Doors	14
Connect the Fly Enclosure	14
Power Connection	14
Signal Connections	14
Using Fly in Portrait Mode	15
Fit the Portrait Door Seal	15
Rotate the Exhaust Cowl	16
Rigging Accessories – Truss Kit	17
Rigging Accessories - Feet	18
Feet – Landscape	18
Feet – Portrait	18
On-site Lens Changes	19
Positive Pressure Fan Control	20
The Fly Rigging Frame	21
Packing/Unpacking the Fly Rigging Frame	22
Fly Rigging Frame Assembly	23
Fly Rigging Frame Tilt Angles	27
Installing Fly Enclosure in the Rigging Frame - Landscape	28
Installing Fly Enclosure in the Rigging Frame – Portrait	30
Portrait Method 1 – Upright Frame	30
Portrait Method 2 – Horizontal	32
Hoisting the Assembled Rigging Frame	35
Remote Monitoring	36

DEC4 Ethernet Adapter – 51.D4.15	37
51.D4.15 Default Configuration.....	37
51.D4.15 Additional Support	37
Digital Enclosure Control	38
Schematic.....	38
DEC4 Main Functions	39
Firmware Revision	39
Factory Settings – Data Modes	39
Hardware Indicators & Fuses	40
Operating Modes.....	41
RDM Only Monitor (Factory Default)	41
RDM+DMX Control	41
RDM+DMX Service	41
DEC4 Control Parameters	42
Control Interface.....	43
User Interface LCD Display.....	44
Control Interface Operation	44
Control Menu.....	45
Set DMX Options	45
Set Temp Units	46
Set Temp Ranges	46
Set Max Humidity	46
Set Lamp Options	46
Set Fan Function.....	47
Status Display.....	48
Safe Mode	50
Safe Mode and Sensors.....	50
Safe Mode – What to do:.....	51
DEC4 Firmware Updates	52
Direct Firmware Update (System Control Board only).....	52
Indirect Firmware Updates	56
Requirements	56
Installation Procedure	56
Troubleshooting.....	61
Warranty	62
Appendix – TEMP Protocol.....	63
Physical Layer.....	63
Developer’s Guide	63

Approvals – Europe



CERTIFICATE AND DECLARATION OF CONFORMITY
FOR CE MARKING

Tempest Lighting, Inc.

11845 Wicks Street, Sun Valley, CA 91352, USA

t: +1 818 787 8984 f: +1 818 252 7101 e: info@tempest.biz

www.tempest.biz

Tempest Lighting, Inc. declares that their

Fly Projector Enclosure Series 71.HS.xxx

complies with the Essential Requirements of the following EU Directives:

Low Voltage Directive 2014/35/EU Test Report 60065-6500-01-14

Electromagnetic Compatibility Directive 2014/30/EU Test Report 61000-6500-03-14

and further conforms with the following EU Harmonized Standards:

EN 60065 : 2014/AC:2016 Test Report 60065-6500-01-16

EN 60529:1991/AC:2016-12 Test Report 60529-6500-02-16

EN 61000-6-3:2007+A1:2011 Test Report 61000-6500-03-14

EN61000-6-1:2007 Test Report 61000-6500-03-14

EN55015:2019/A11:2020 Test Report 61000-6500-03-14

Dated: 21st July 2023

Position of signatory: President

Name of Signatory: Tim Burnham

Signed below:

on behalf of Tempest Lighting, Inc.

.....

Approvals – China



强制性认证目录外产品确认书
Confirmation Letter for Products
Outside the Scope of China Compulsory Certificate

Ref. No: CL-TEMPEST-160818-1

申请人: Applicant: Tempest Lighting Inc.		地址: Address: 11845 Wicks St., Los Angeles, CA 91352 United States
生产厂名称: Factory: Tempest Lighting, Inc.		地址: Address: 11845 Wicks St., Los Angeles, CA 91352, USA
产品名称: Product Name: 投影仪外壳, 灯具外壳 Projector Enclosures Moving Light Enclosures Lighting Enclosures	型号: Model: 18xx.IN, 19xx.IN, 2xxx.IN, 66xx.IN, 52.xxx.IN, 53.xxx.IN, 54.xxx.IN, 55.xxx.IN, 56.xxx.IN	商标: Trademark: Tornado, Twister, Thunder, Blizzard, Whispr, Typhoon, Cyclone, Tacit
产品标准: Standard: /		HS code: 9405.99.0000
产品描述(包括使用场所) Product Description (utilization of product) : Enclosures for high-powered luminaires and video projectors for outdoor use and indoor noise attenuation. For professional use only. 产品为用于户外和室内噪声衰减大功率灯具和视频投影仪的外壳。仅供专业使用。		
确认意见 Conclusion: According to the product description, the models above are out of CCC scope 基于产品描述, 如上型号的产品在中国强制性产品目录之外。 本确认书的有效有效期至: August 18th, 2017 Validity Period		



Introduction

Thank you for purchasing a Tempest enclosure! We have worked hard to provide you with the very best product available for its purpose, and we shall continue to do everything possible to ensure that it works well for you for many years to come.

Please read this manual before starting work!

In the event of difficulty, please contact your Tempest reseller or Tempest direct:

info@tempest.biz

+1 818 787 8984

We will do everything we can to help you get the very best results from your Tempest enclosure.

IMPORTANT: Safety Advisories

- All installation and rigging work done must where applicable be designed and built in accordance with norms and standards of the local authority having jurisdiction of the installation site. It is the responsibility of the installer to obtain such approvals as may be required to achieve full compliance.
- All electrical work must be carried out by a suitably licensed electrical contractor in full compliance with local electrical standards.
- Lifting: some enclosures and the equipment inside them may be heavy. Use properly rated lifting equipment where appropriate and never attempt to carry out work with fewer than the number of workers needed to lift safely.
- It is the responsibility of the installer to ensure that all local building, safety and electrical codes are strictly adhered to in the installation of this enclosure. Tempest Lighting, Inc., its employees and agents are in no way responsible for damage arising from failure to follow either the instructions in this manual or building, safety and electrical codes prevailing at the installation location.
- Do not attempt to install or operate the enclosure before fully reading and understanding this manual
- Never allow anyone who has not read this manual to open the enclosure or perform maintenance on the projector within.
- Never leave the enclosure unattended when open.
- Always make sure all bolts and latches are tight and safety locks are in place after performing any form of maintenance on the unit.
- Do not open any electrical boxes until power has been shut off to all supply lines to the enclosure (including the one powering the projector).
- Do not open the enclosure in wet weather.

Supported Projectors

	Fly 25	Fly 35	Fly 50	FLY 50+
Barco UDX			•	•
Barco UDM		•	•	•
Barco F90	•	•	•	•
Barco F80	•	•	•	•
Christie Griffyn 4K50			•	•
Christie Griffyn 4K35			•	•
Christie M4K25	•	•	•	•
Christie HS Series	•	•	•	•
Epson L-30000			•	•
Epson EB-2022PU	•	•	•	•
Epson EB-1000PU	•	•	•	•
Panasonic PT-RQ50K				•
Panasonic PT-RQ35K		•	•	•
Panasonic PT-RQ25K	•	•	•	•
Panasonic PT-RQ21K	•	•	•	•

This shows a small selection of popular projectors in the equipment rental space. Contact Tempest for projectors not shown here, and to discuss your present and likely future requirements.

Clearances

Air Clearance

Observe the minimum clearances shown around your enclosure

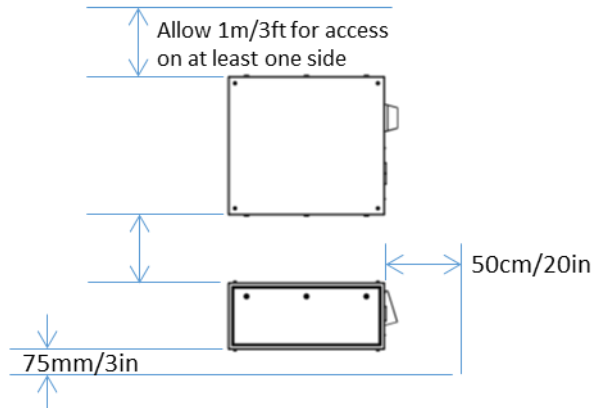

Snow Clearance

In areas where snow is likely, make sure the base of the enclosure is at least 24" [60cm] above highest potential snow drift level.

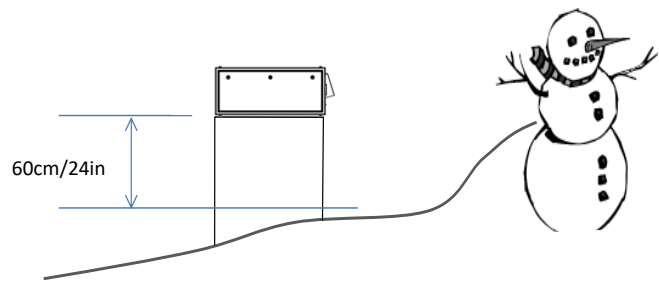

Assembling the Fly Enclosure

There are many steps described here, but with a little practice assembly takes only a few minutes.

Place the folded Fly chassis on a flat surface.

1. pull out the quick-release pins securing the front and back to the enclosure base (you may need to tap the pins out when the enclosure is new).

Fly quick-release pin and tether.

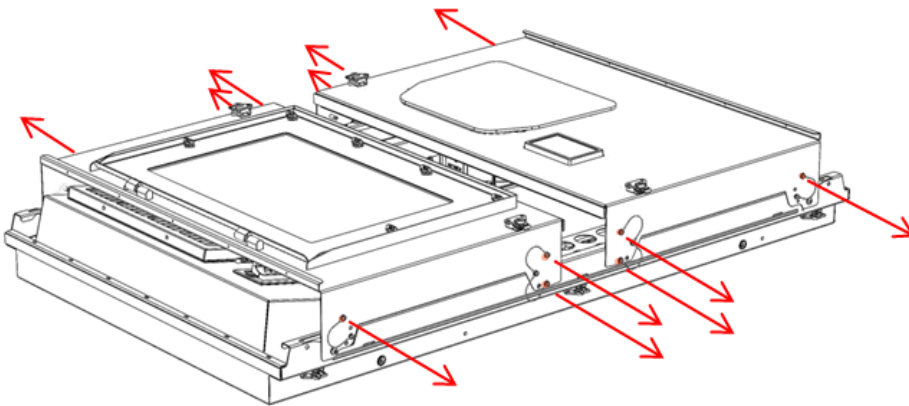

2. Rotate the front and back panels to the upright position

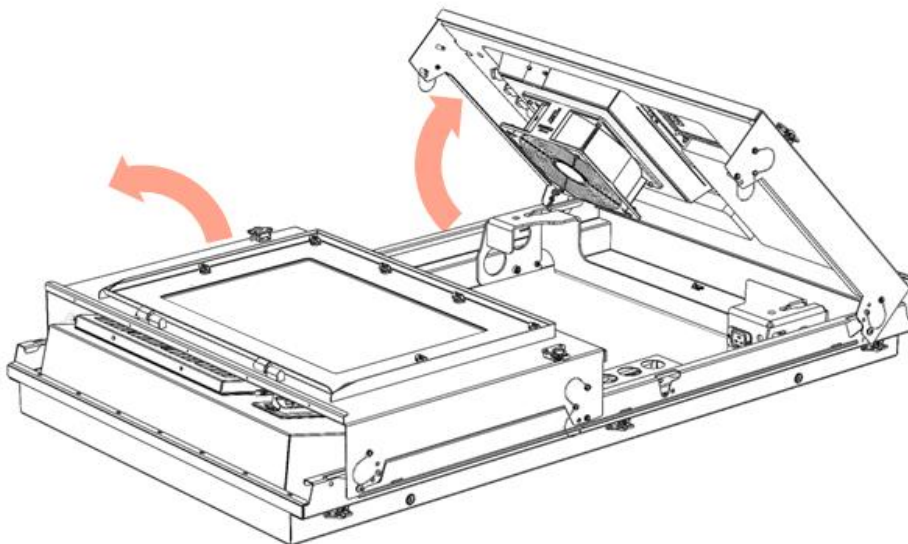

3. Lock in place by inserting 4 quick-release pins in the locations indicated

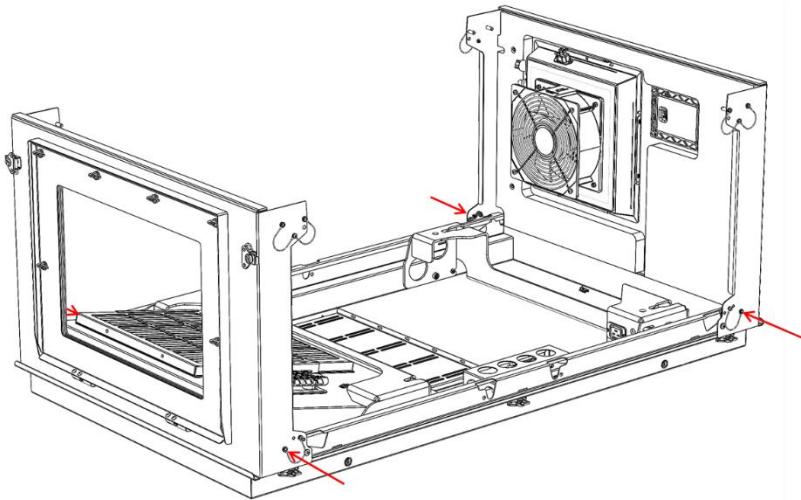

Install Auxiliary Equipment

If you need additional equipment inside the Fly enclosure, such as small media servers, fiber boxes, etc, it is easiest to install them before installing the projector.

Attach such equipment to the aux rack in the enclosure base using cable ties.

Connect power to the C13 outlet provided on the front of the back projector beam, using the C14 plug provided.

Note: For use in North America and Japan, the C13 outlet is fed from a discrete C14 100-120VAC inlet above the exhaust fan. For 230V systems the aux power is in parallel with the 230V projector power outlet.



No-one ever has a C14 plug with them, so we supply one with every enclosure.

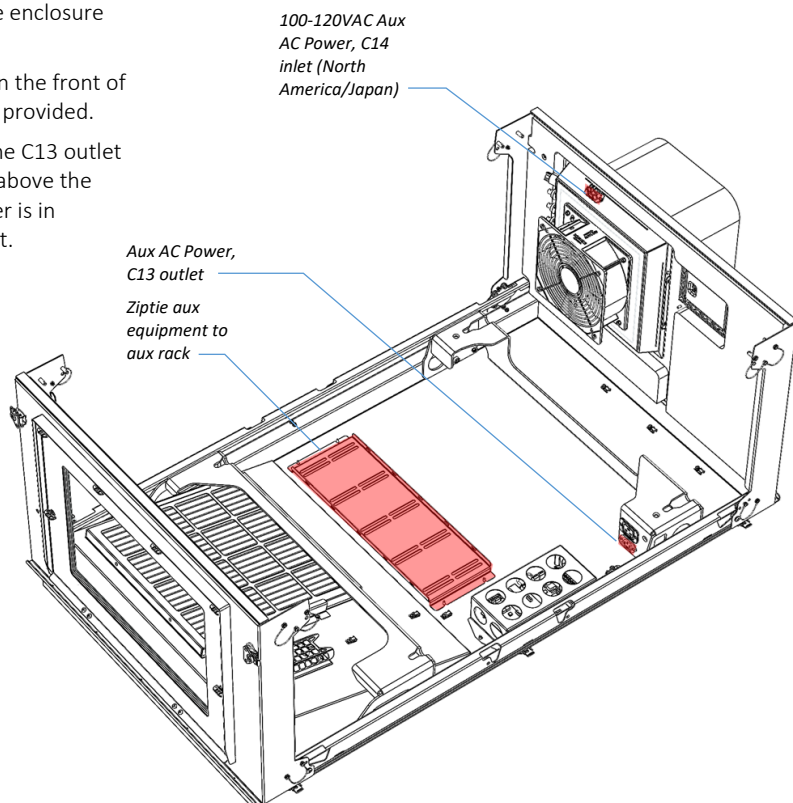

Installing the Projector

Remove the projector feet if necessary and mount the projector to the Projector Mounting Plate, using the projector's feet or ceiling mount threaded holes.

For projectors not presently supported in the Fly system, you may need to drill the appropriate hole pattern in the Small Projector Mounting Plate.

Projectors vary – this Panasonic RQ35 uses four M10 flathead screws to mount into the projector feet sockets.

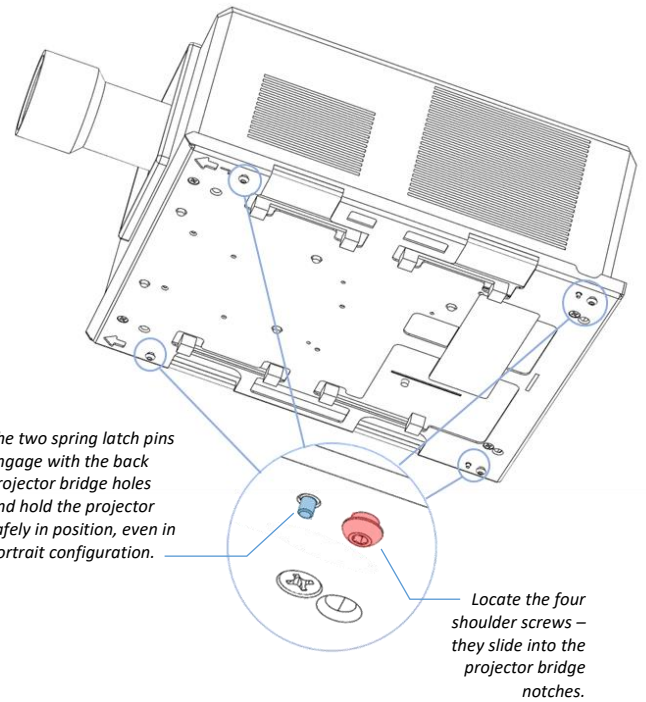
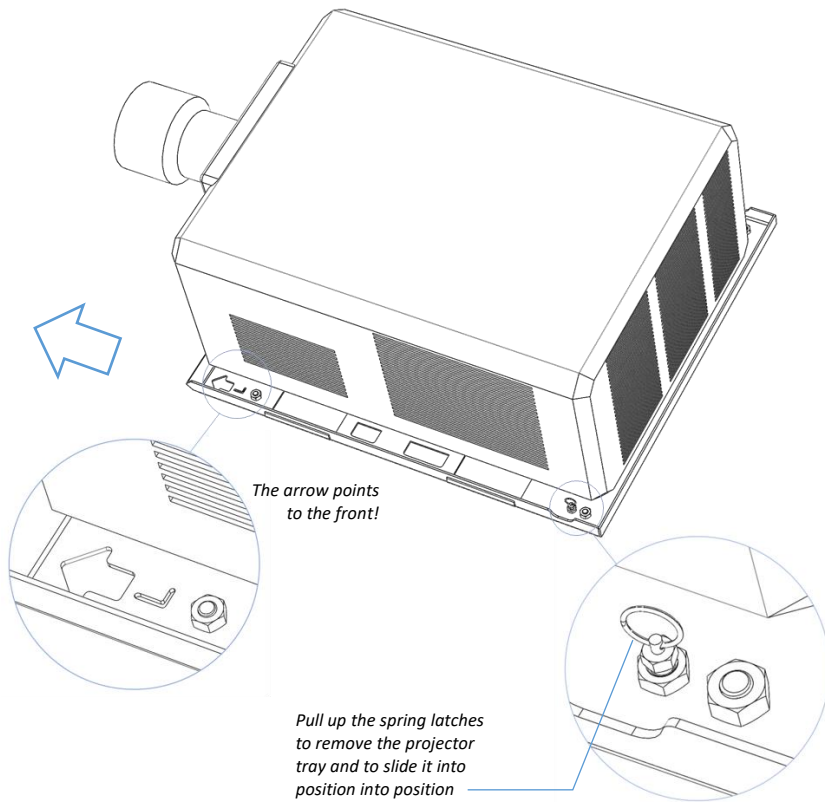
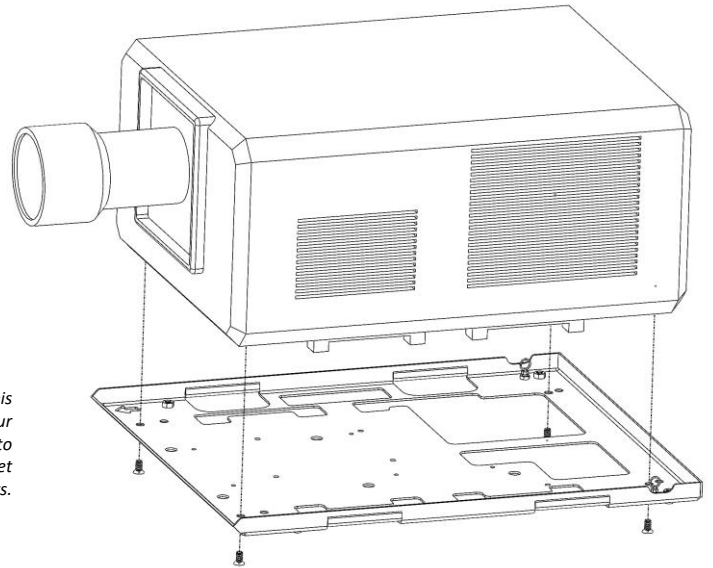

Fitting the Projector Tray

Depending on the projector, AT LEAST TWO people are needed for this step!

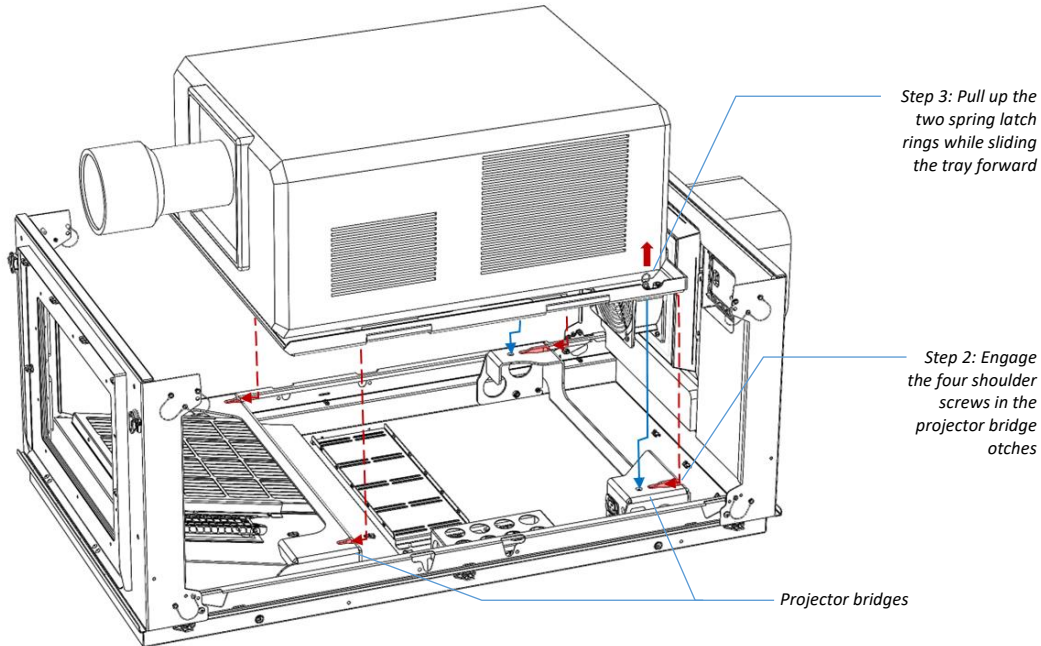

1. Set the projector tray on the two projector bridges.
2. Slide the tray forward until all four shoulder screws engage with the bridge notches.
3. Lift up the two spring latch rings and slide the tray forward until the latches engage.
4. Release the two spring latches.

CHECK THAT THE PROJECTR TRAY IS SECURE AND CANNOT SLIDE OUT OF POSITION.

Connecting the Projector

Plug the projector power cable into the C19 outlet provided (use an IEC 60320 C20 plug).

Connect projector signal cables to the feedthroughs on the side of the fan box.

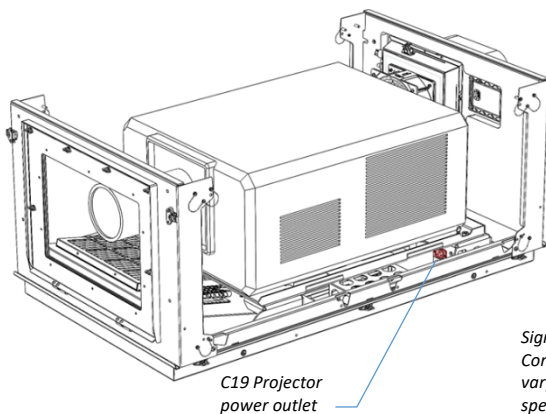

Signal Feedthrough Connectors. Types vary by customer specification.

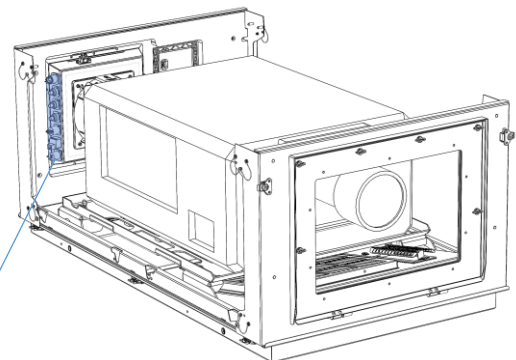

Fit the Enclosure Top Cover

With the projector in place, fit the Fly top cover assembly:

Place the cover on the front and back enclosure panels.



Press 8 quick-release pins into the locating holes – 2 at each corner.

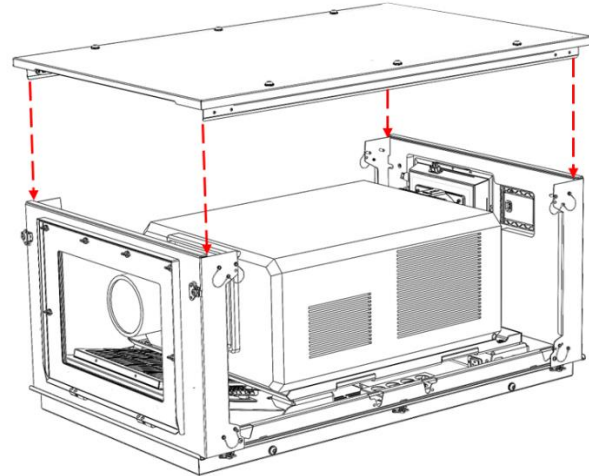

WARNING: FOR SAFE OPERATION ALL 8 PINS MUST BE ENGAGED

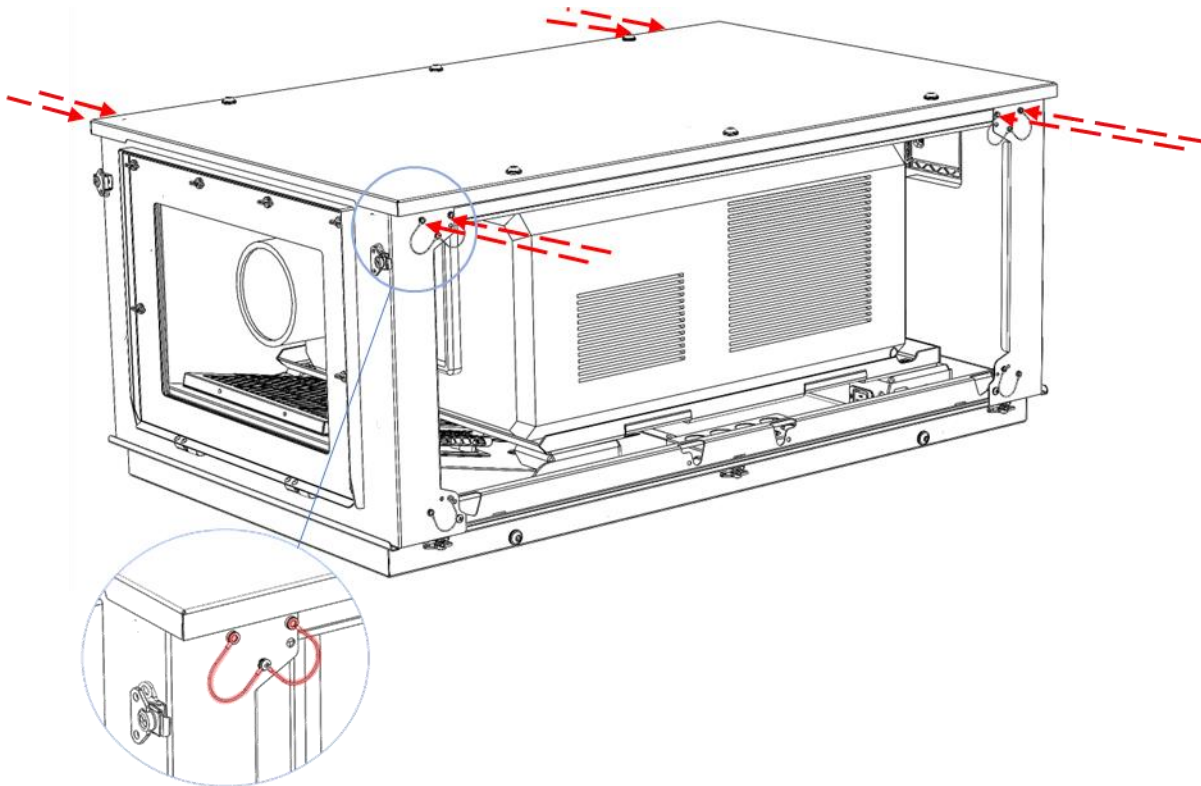

Fit the Side Doors

Attach the doors, using the five butterfly latches.

Note the three alignment tabs
On the inside of the door locate
In the corresponding slots in the
Enclosure chassis.

Note: for portrait operation, see the
Next section.

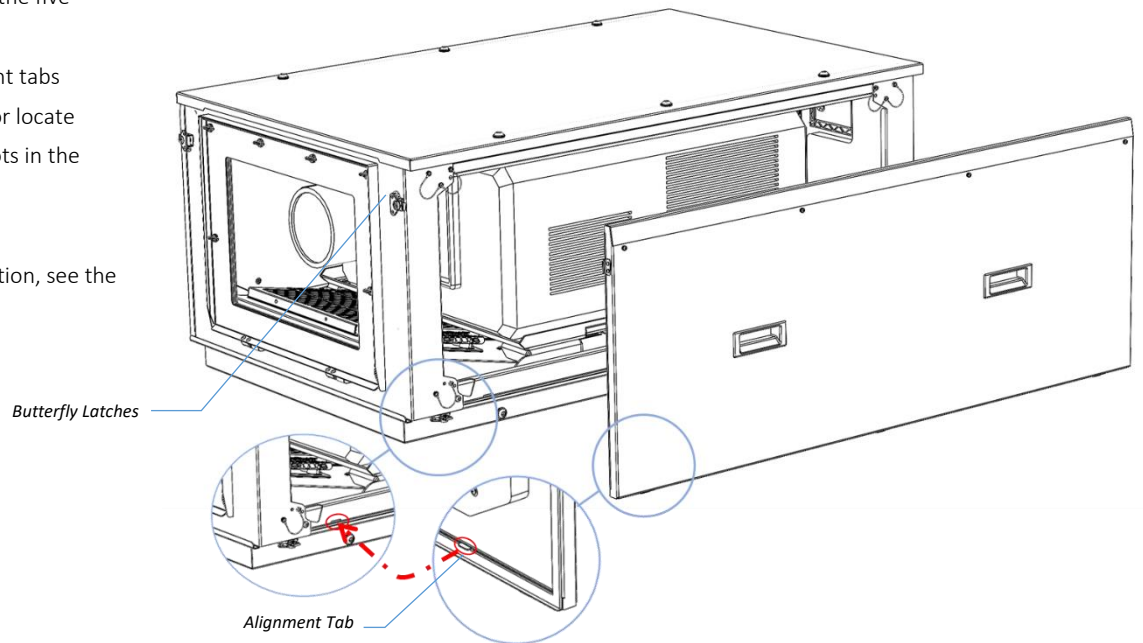

Connect the Fly Enclosure

Power Connection

230V Systems (International):

Connect the supplied 230VAC (L, N, E) power cable with Neutrik PowerCon True 1 TOP female line connector to the power inlet connector inside the fan box opening.

200-208V Systems (North America, Japan):

Connect the supplied 200-208VAC (L1, L2, E) power cable with Neutrik PowerCon True 1 TOP female line connector to the power inlet connector inside the fan box opening.

IMPORTANT:

When used outdoors the Fly enclosure must be powered 24/7 to protect the projector outside of showtimes.

Signal Connections

Connect signal cables to the feedthrough connectors inside the fan box opening.

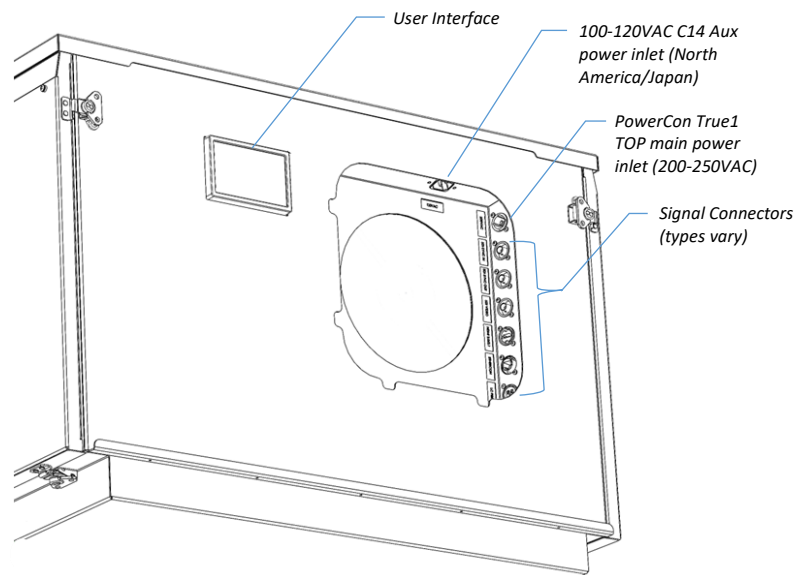

Using Fly in Portrait Mode

Fly enclosures may be used in portrait orientation, with only minor adjustments.

First, assemble the Fly enclosure and install aux equipment and the projector, as shown above.

Rotate the enclosure into portrait orientation, with the right side up.

FLY MUST BE USED RIGHT SIDE UP IN PORTRAIT MODE, WITH THE AIR INLET DOWN. NOTE THAT ANY RAIN ENTERING THE AIR INLET WILL SIMPLY DRAIN OUT IN THIS ORIENTATION.

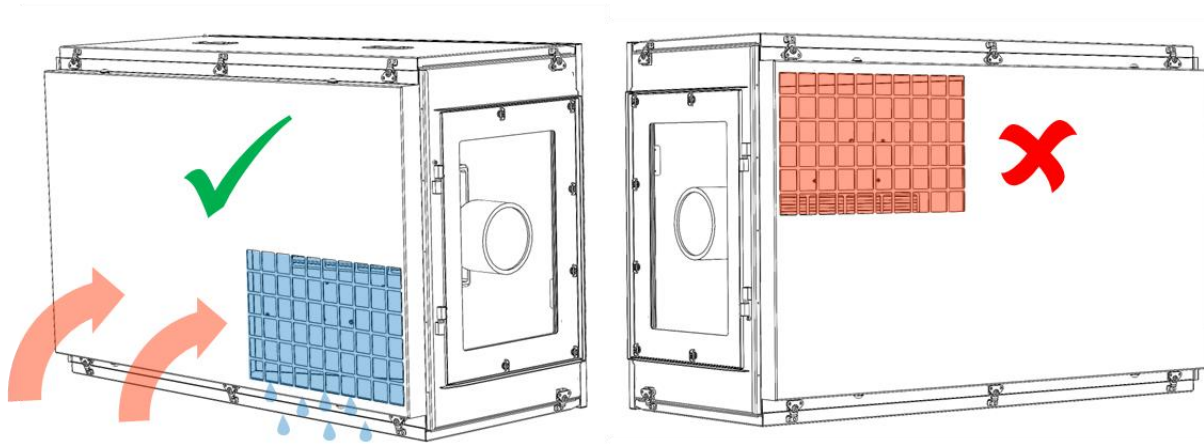

Fit the Portrait Door Seal

In portrait mode, the supplied Portrait Door Seal is required for weather protection.

Remove the four screws and rubber washers on the right (upper) side door.

Place the door seal in position and fasten using the same four screws and washers.

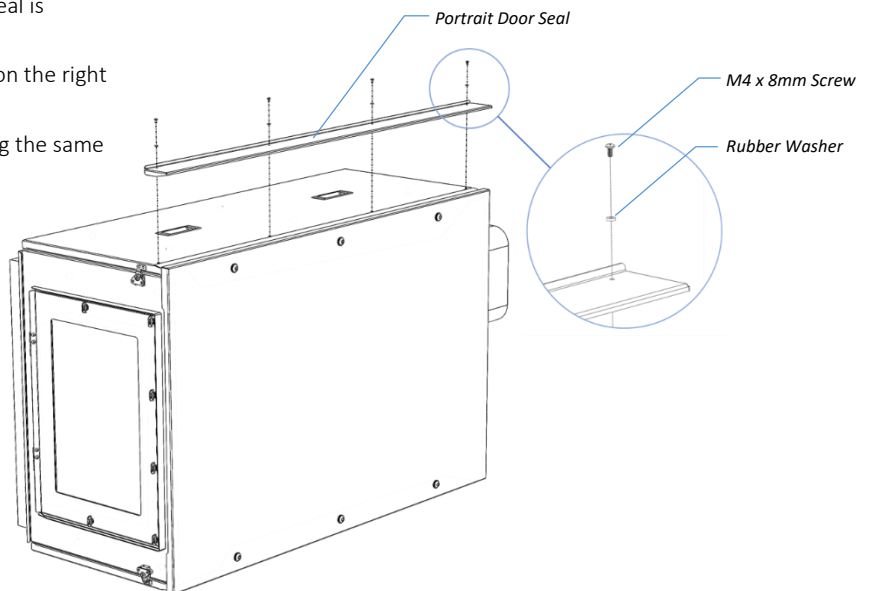

Rotate the Exhaust Cowl

(this is easier to do than to describe!)

1 Remove the exhaust cowl by pressing up into the corners and prying out each leg in turn.

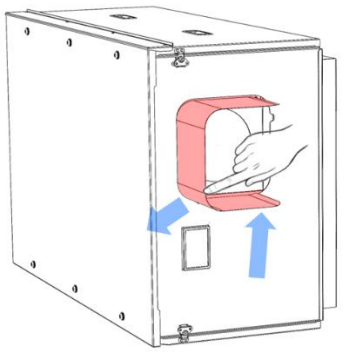

2 Rotate the cowl 90 degrees for portrait use.

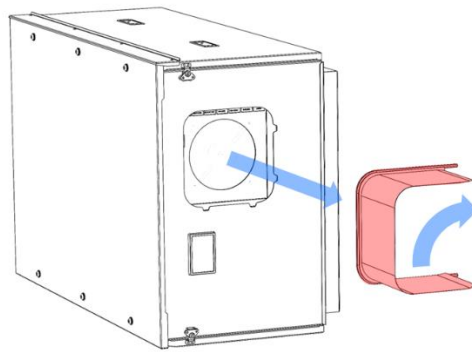

3 Replace the cowl by reversing the actions in step 1.

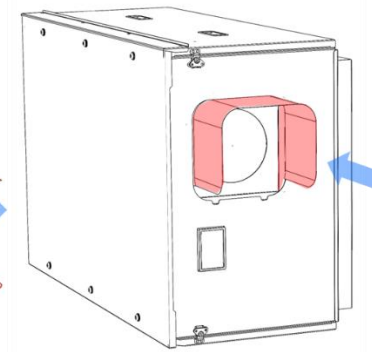

Your Fly enclosure is now ready for portrait use.

Rigging Accessories – Truss Kit

The truss kit may be used in either landscape or portrait format, to hang a Fly enclosure from any truss with poles between 12-24in (305-610mm) apart.

Attach each truss beam to the three M10 threaded holes on the top of the Fly enclosure.

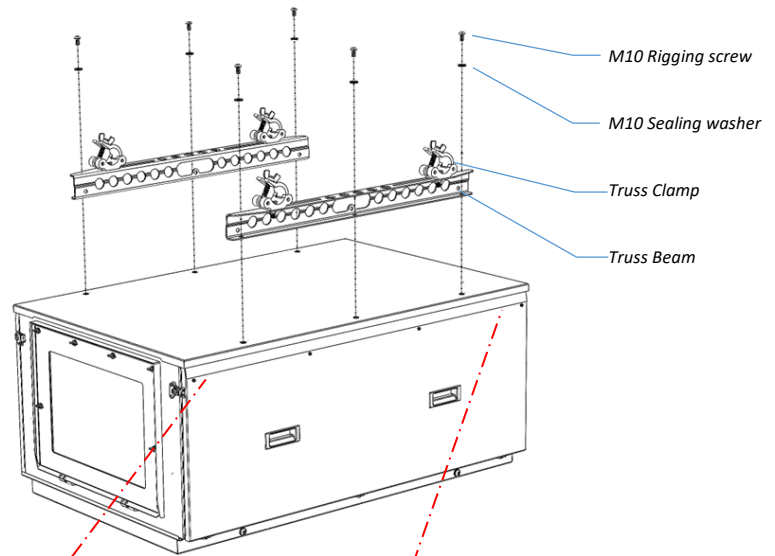

IMPORTANT – SAFETY CHECK:

CHECK THAT ALL 8 QUICK-RELEASE PINS ARE CONNECTING THE TOP COVER TO THE FRONT AND BACK PANELS (BOTH SIDES).

In portrait mode the truss beams mount differently – one to the base, the other to the cover.

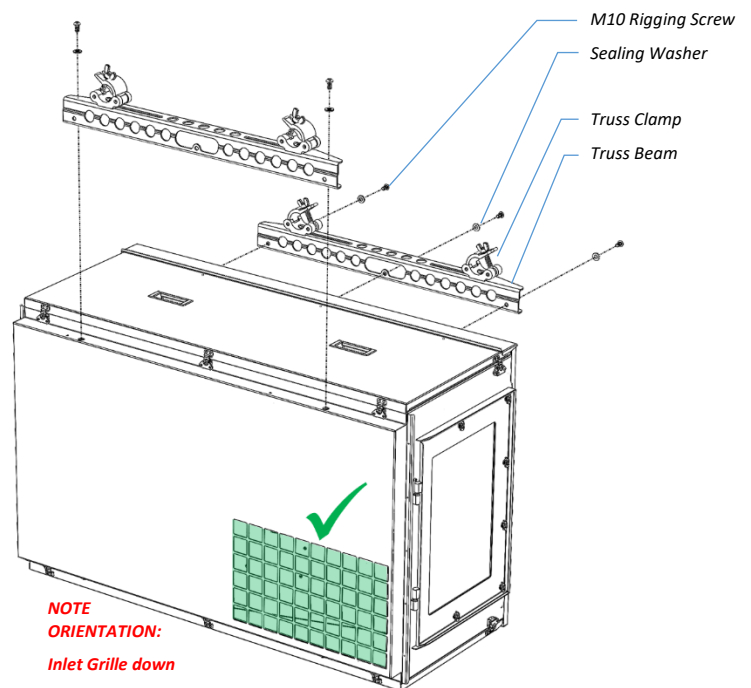
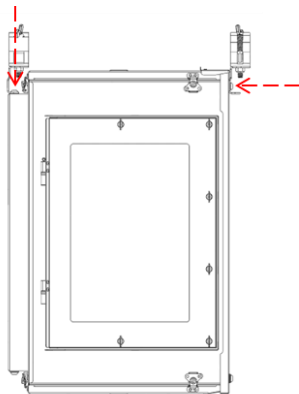

Adjust the distance between the truss clamps to correspond with the truss being used and tighten the truss clamp nuts.

Hang the enclosure on the truss and **TIGHTEN THE TRUSS CLAMPS SECURELY.**

Tempest and its agents will not be liable for damage if ^{Truss Clamp Nuts} these instructions are not followed correctly.

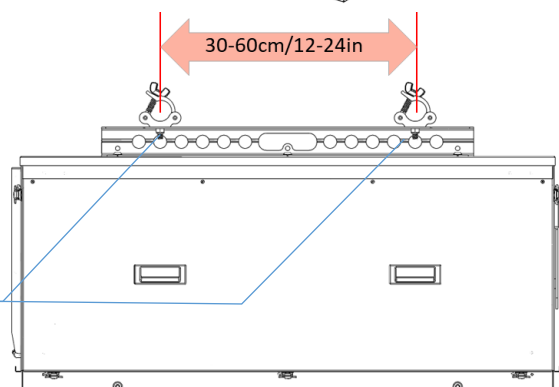

Rigging Accessories - Feet

Feet – Landscape

If the Fly enclosure is to be set on its base in landscape mode, the inlet grille **MUST** have at least 75mm/3in clearance below to allow airflow to the projector.

This can be assured using the Fly Feet Kit.

Mount the four feet to the M10 threaded holes on the enclosure sides, using the M10 screws provided.

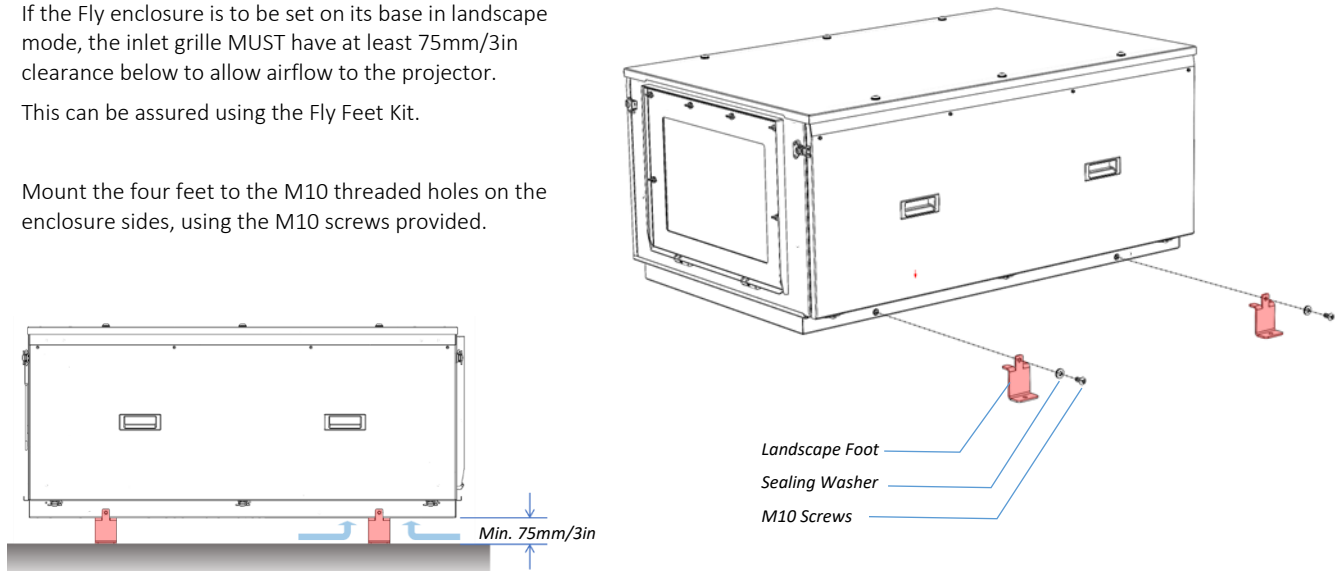

Note that a minimum clearance of 75mm/3in is required below the inlet grille for airflow.

Feet – Portrait

The portrait feet are asymmetrical:

Note that since the air inlet is on the side in portrait mode, airflow clearance below the enclosure is not mandatory.

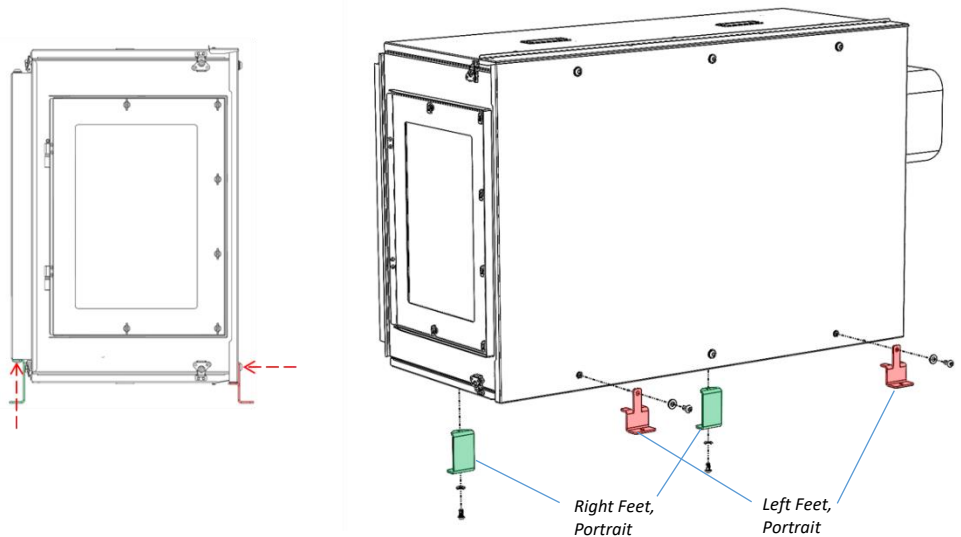

On-site Lens Changes

Fly's port glass opens from the front for quick and easy lens changes, without opening the enclosure or moving the projector.

Simply undo the quarter-turn fasteners and open the door to access the projector lens.

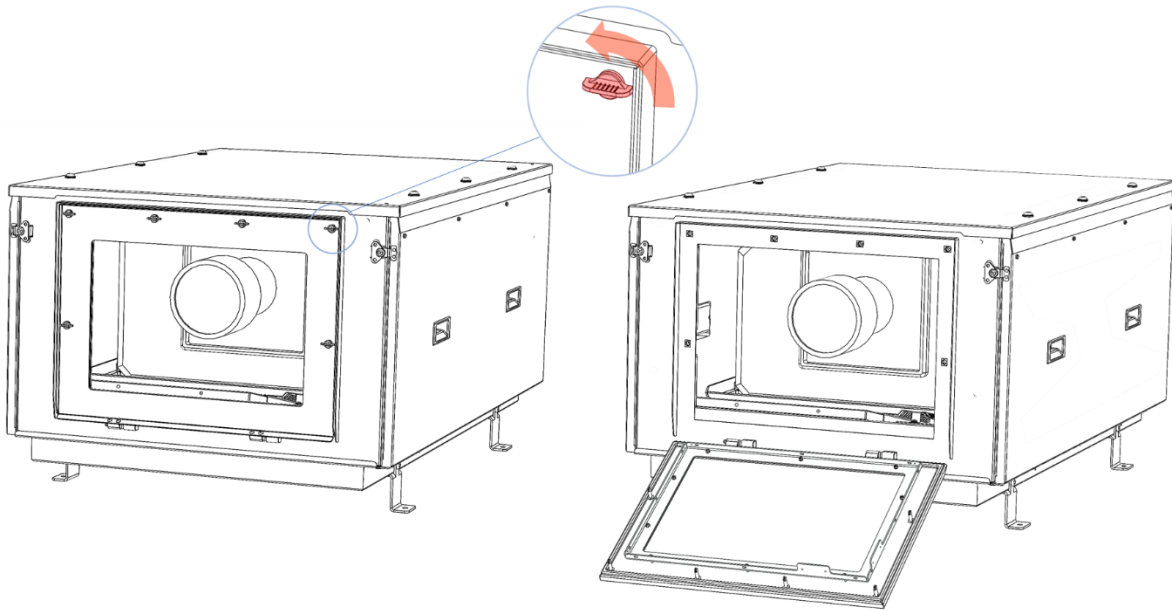

Note: A deeper door is available as a custom option for extra-long lenses. Contact Tempest for details.

Positive Pressure Fan Control

Specify the Positive Pressure option when ordering:

- Normally the enclosure fan(s) will run only when either the projector/luminaire lamp is on, or if the daytime temperature in the enclosure exceeds the DEC Upper Temperature setting. At all other times the fan is OFF.
- With the Positive Pressure option, when the fan would normally be off, it is instead powered via a capacitor that lowers the operating voltage so that the fan continues to run at a low level, maintaining positive pressure in the enclosure and preventing harmful contaminants from entering through the exhaust path.

Fan Control Board

Capacitor

Fan

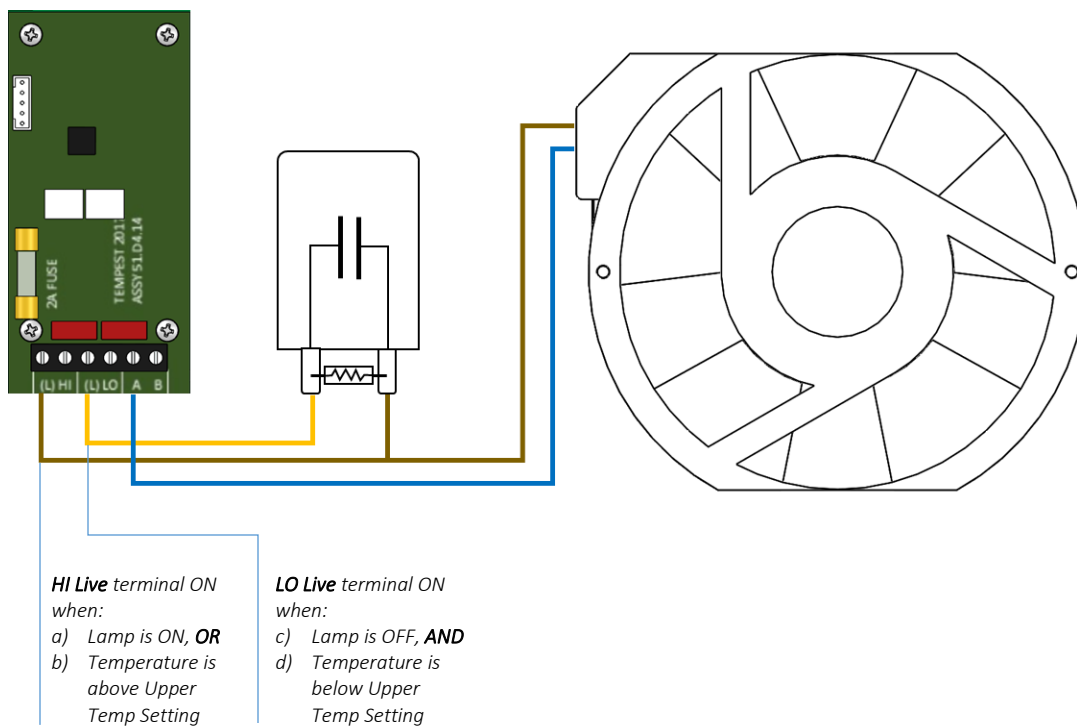

The Fly Rigging Frame

This strong but very lightweight frame supports up to three Fly enclosures and projectors, in either landscape (right) or portrait (below) configurations.

In landscape mode, enclosures may be installed shooting up (as shown here), or the enclosures may be reversed, for shooting down from a high position.

Enclosures may be installed in the rigging frame at a variety of angles, from horizontal to 45 degrees tilt up or down (left/right in portrait mode).

In either configuration, the Fly Rigging Frame can be fully assembled and tested with enclosures and projectors, before being hoisted into position atop buildings or other structures.



The Fly Rigging Frame packs into a compact case (not included¹) for easy transportation by air or truck, and rigging time is less than five minutes for two people.



¹ Ask Tempest for case internal dimensions to share with your case supplier or talk to Tempest about case supply.

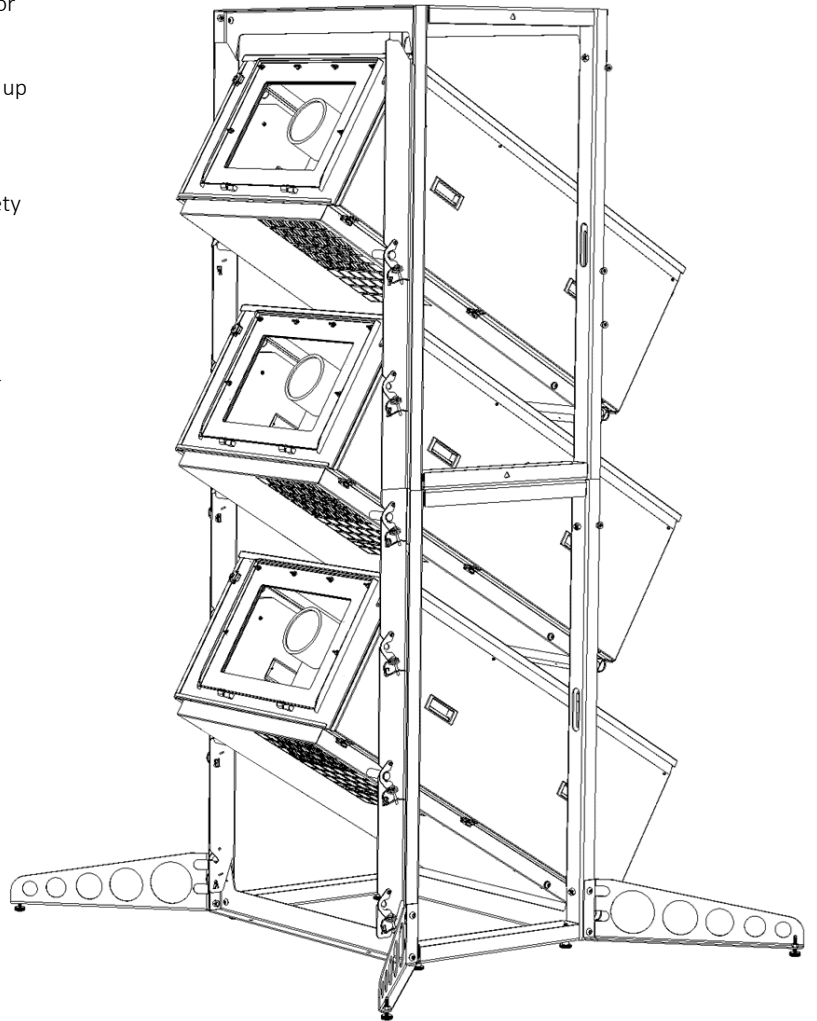

Rigging Frame with three Fly enclosures, landscape configuration.

Packing/Unpacking the Fly Rigging Frame

Packing and unpacking in the right sequence saves time and shortages!

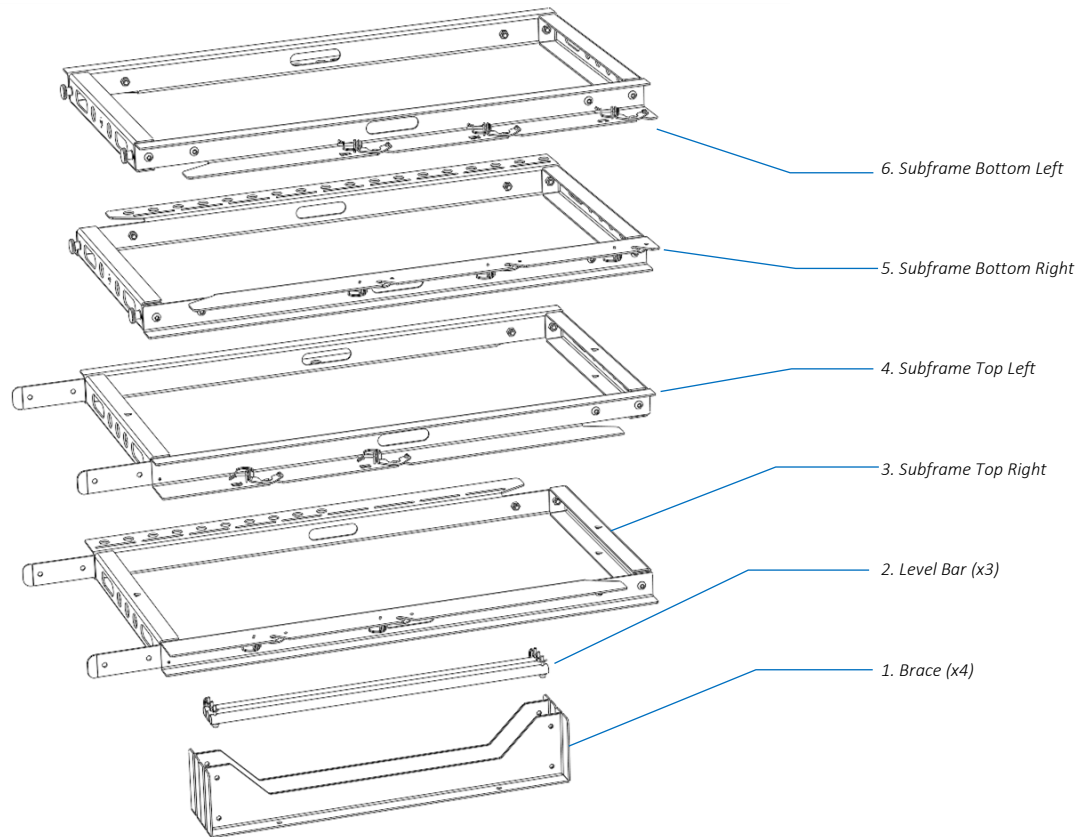

Fly Rigging Frame Assembly

Tip: Use a screw gun with an 8mm ball-nosed hex bit (bit is included):

DO NOT OVER-TIGHTEN SCREWS.



Step 1

Assemble brace to bottom subframes

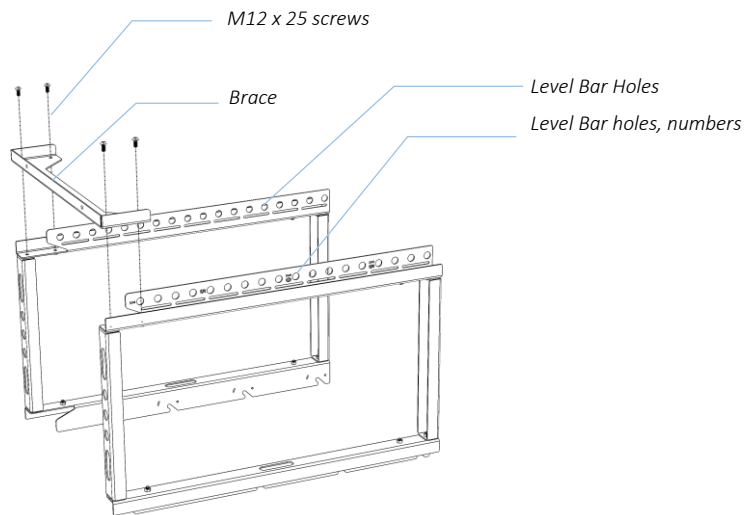

Step 2

Flip the frame over and add the second bottom brace

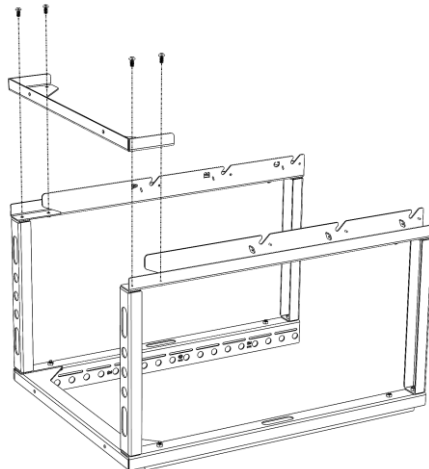

Step 3

Slide in the top subframes.

Secure with 4 screws.

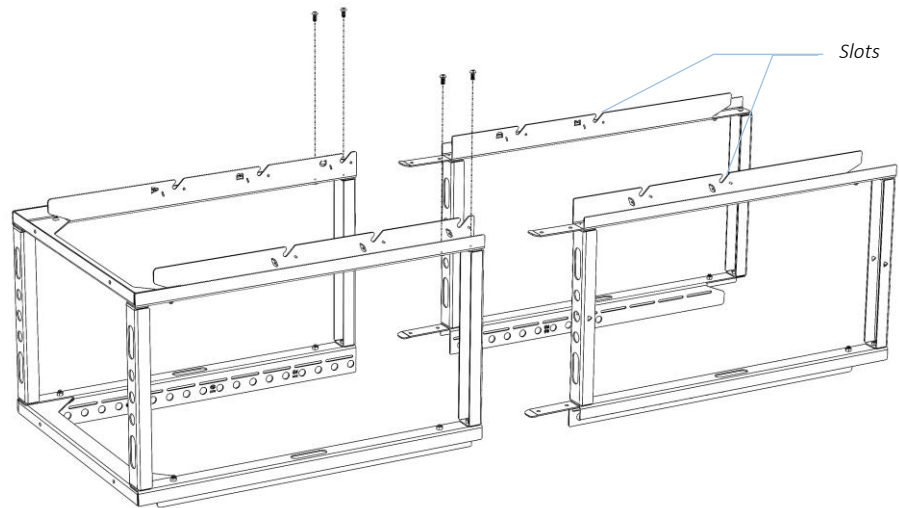

Step 4

Attach the first top brace

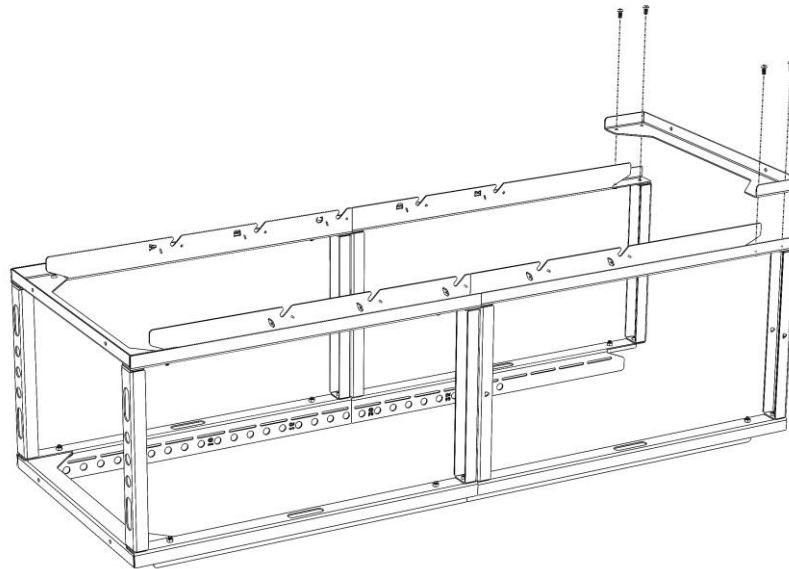

Step 5

Flip over

Secure top subframe screws

Add second top brace.

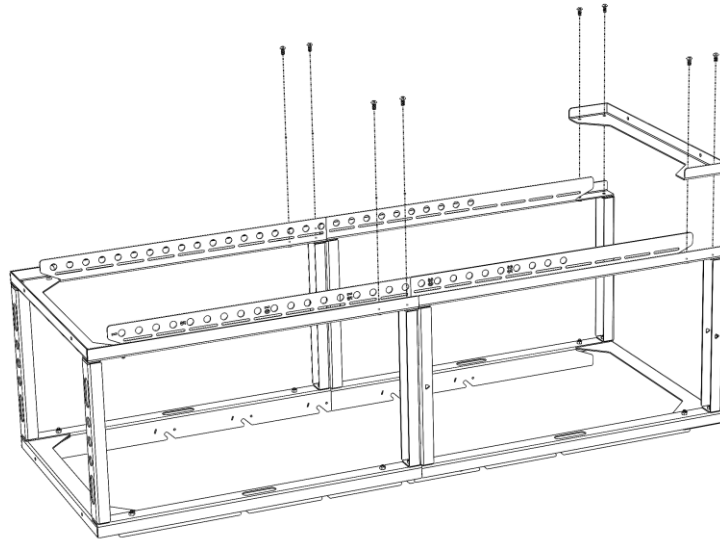
Step 6

Add the three level bars to the required numbered level bar holes (see next section).

Secure with a spring clip at both ends

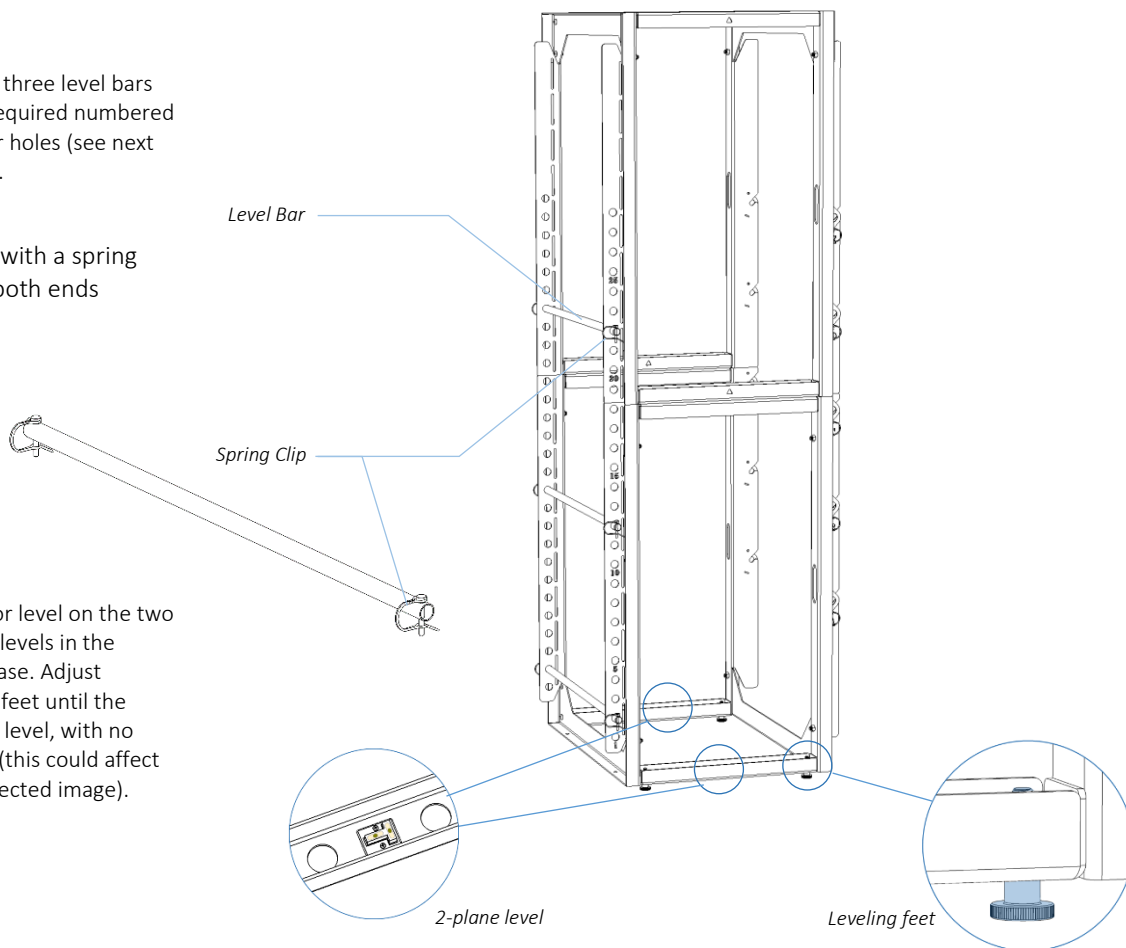

Check for level on the two 2-plane levels in the frame base. Adjust leveling feet until the frame is level, with no wobble (this could affect the projected image).

Step 7 - Stability

In vertical mode, the rigging frame must be stabilized for safety in windy conditions.

This can be done in two ways:

1. Bolt to substrate

Use the holes in the frame base to bolt to a solid surface, using M12 or ½" hardware.

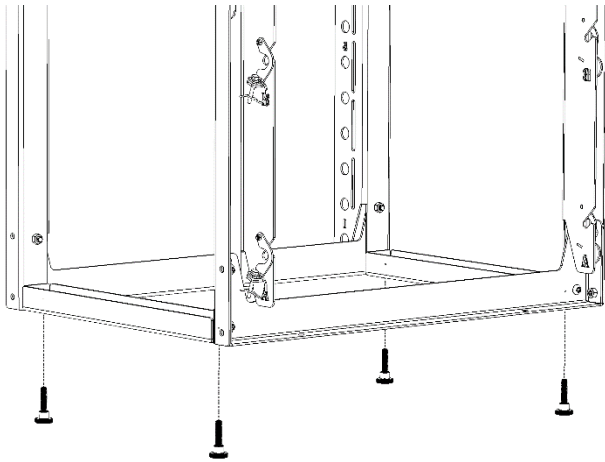

Optional: unscrew leveling feet

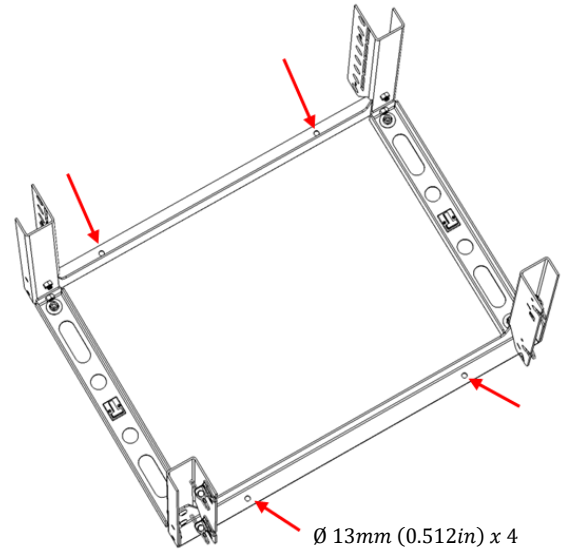

Fix to a secure surface using M12 or ½" hardware.

2. Use Outriggers

Bolt the four outriggers to all four corners of the Rigging Frame base, using two M12 screws per outrigger (provided).

Adjust the leveling feet for stability.

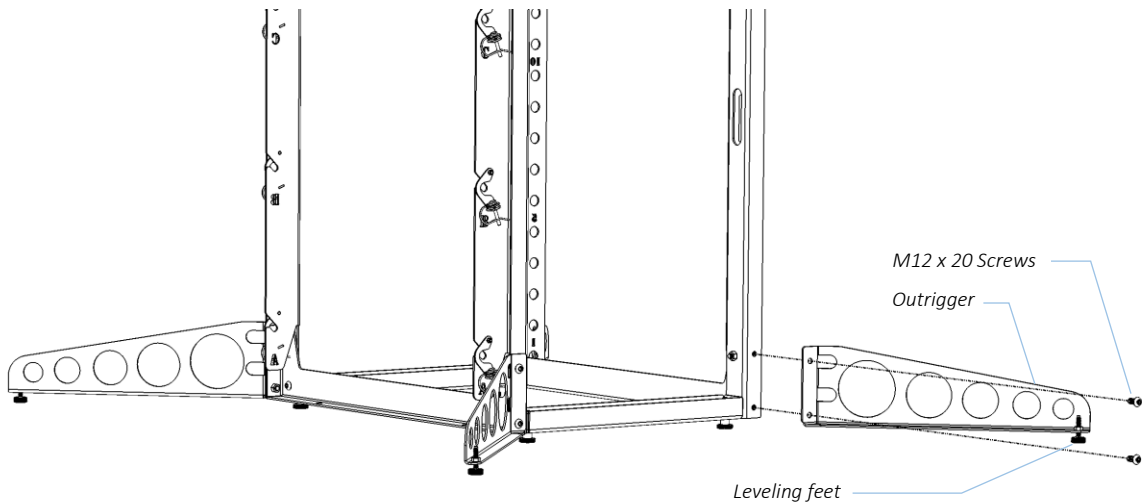

THE INSTALLER/USER IS RESPONSIBLE FOR INSTALLING ALL EQUIPMENT IN COMPLIANCE WITH ALL SAFETY STANDARDS IN THE JURISDICTION OF THE INSTALLATION.

Fly Rigging Frame Tilt Angles

Steeper angles may be achieved by using only two enclosures per rigging frame.

Remember, shooting DOWN = lens over level bar, shooting UP = fan over level bar.

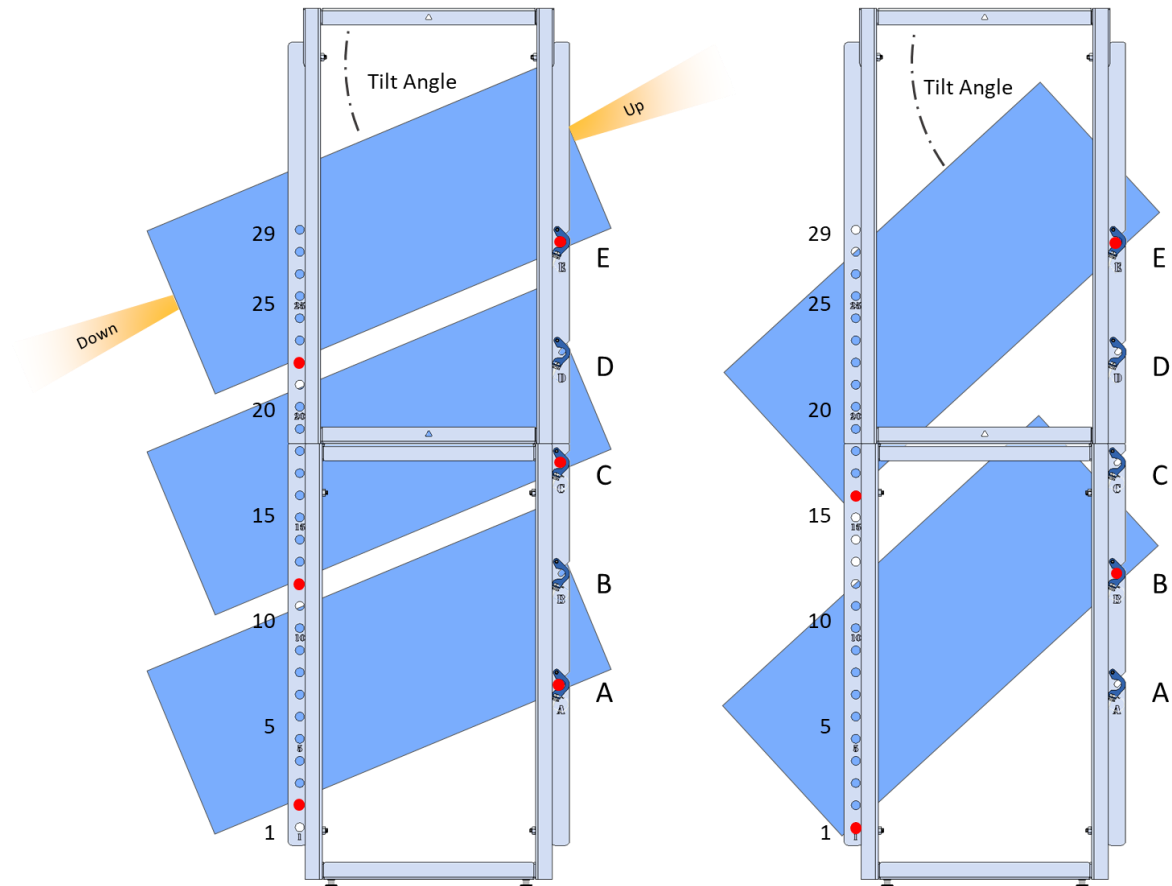

3 Enclosures							
Back	Front						
E	21	22	23	24	25	26	27
C	11	12	13	14	15	16	17
A	1	2	3	4	5	6	7
Tilt Angle °	26.9	23.0	18.8	14.4	9.8	5.0	0.2

2 Enclosures							
Back	Front						
E	16	17	18	19	20	21	22
B	1	2	3	4	5	6	7
Tilt Angle °	42.7	40.1	37.2	34.0	30.6	26.9	23.0

Installing Fly Enclosure in the Rigging Frame - Landscape

To the fully assembled Fly landscape enclosure, remove the M8 screws from two of the side mounting holes, and replace them with the two landscape frame adapter knobs.

The adapter knobs should be hand-tightened to touch the side of the base frame. **Do not overtighten.**



If the enclosure is to be installed projecting DOWN, screw the adapter knobs to the **back** of the base frame:

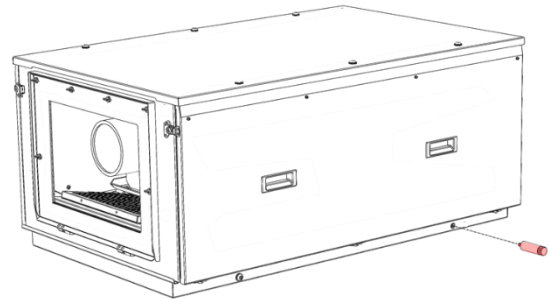
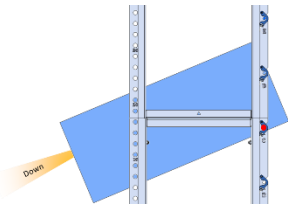

If the enclosure is to be installed projecting UP, screw the adapter knobs to the **front** of the base frame:

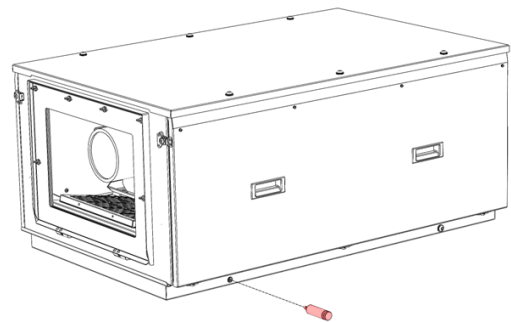
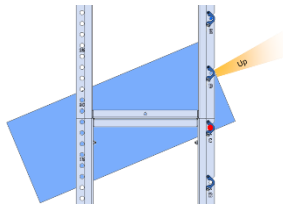

Using the chart on the previous page, determine the locations for the level bars and install them in the front verticals of the rigging frame.

Be sure to attach one spring clip at each end of the level bar to prevent accidental removal.

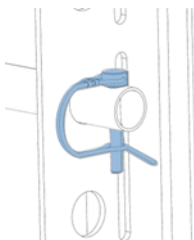

Spring Clip, correct installation

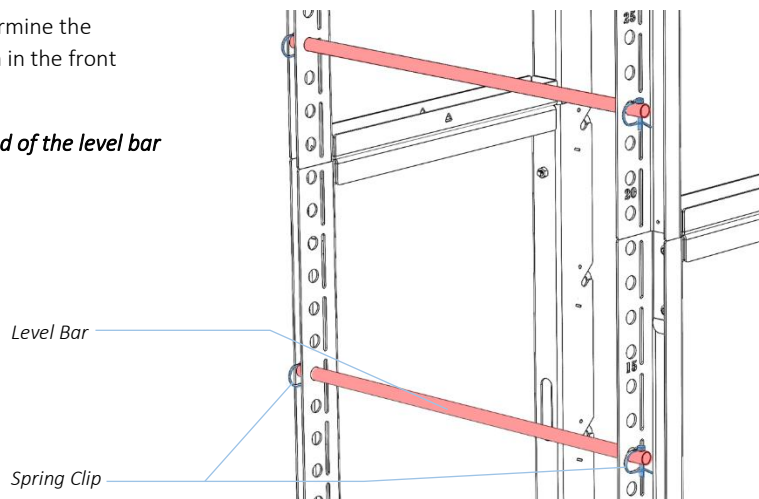

Using the same chart, determine which slot (A – E) to use for the rear enclosure support.

Remove the spring clips from the safety hooks on both sides and flip the hooks up out of the way.

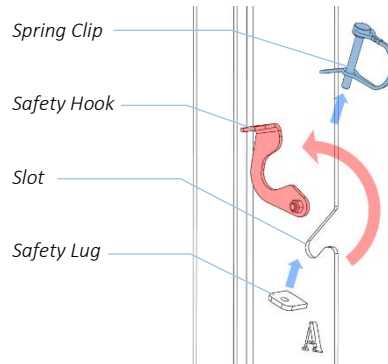

1. Lift the assembled Fly enclosure and insert it into the rigging frame from the back.

Depending on which projector is used, this may require up to four people.

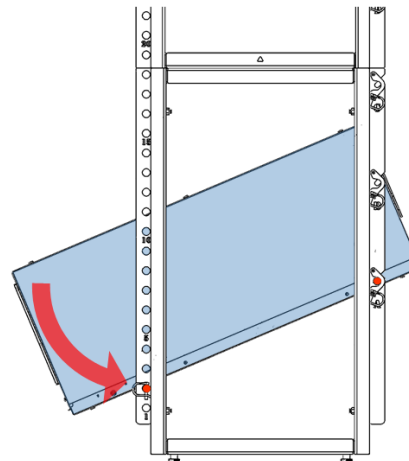
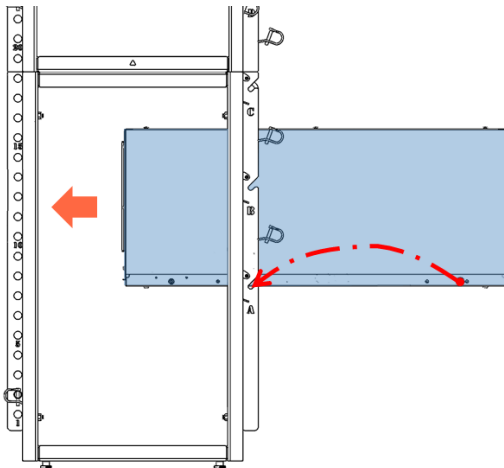

IMPORTANT:
Close safety hooks and secure with spring clips both sides

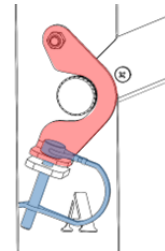

2. Locate the frame adapter knobs into the desired slots and rest the front of the Fly enclosure on the appropriate level bar.
3. Lower the front of the enclosure onto the desired level bar.
4. Close the safety hooks both sides, insert and fasten both spring clips.

Installing Fly Enclosure in the Rigging Frame – Portrait

Portrait Method 1 – Upright Frame

One or two Fly enclosures may be rigged in this configuration, either both portrait, or one portrait, one landscape. Note that the left and right portrait mounts are different.

Note also that the following illustrations assume the projectors will shoot DOWN from the frame. To shoot UP, mount the portrait mount brackets at the other end of the portrait bars – illustration on the next page.

Right Side – shooting down:

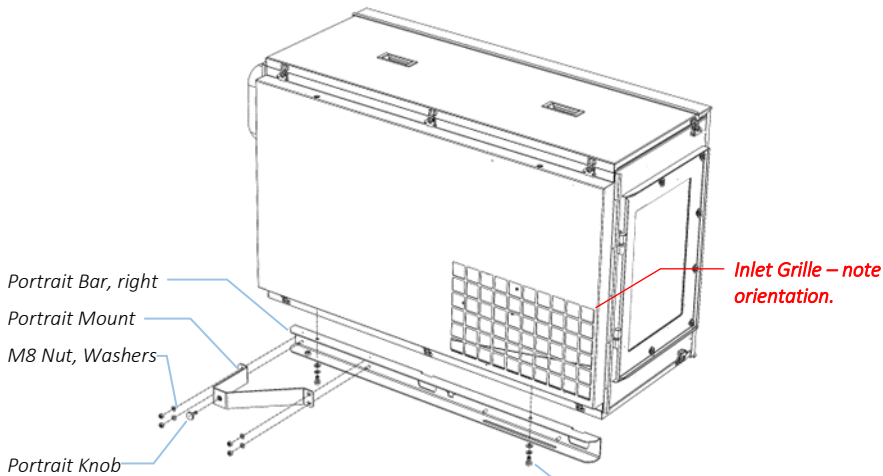

Left Side shooting down:

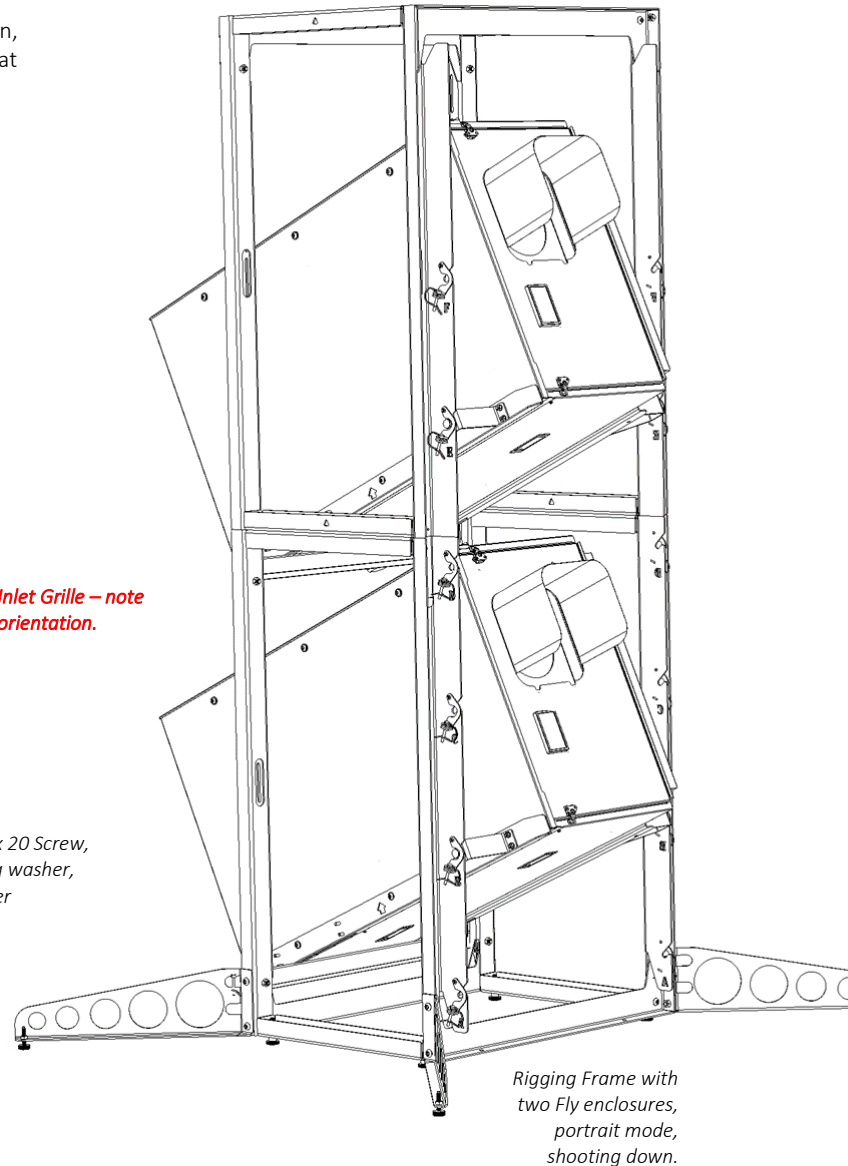
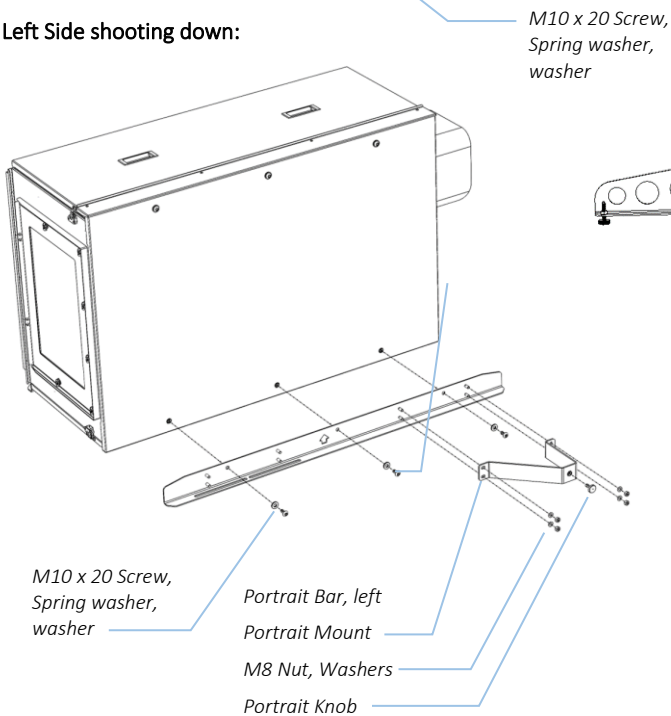

1. **IMPORTANT** – align so that the inlet grille is DOWN.
2. Mount the assembled enclosure to the rigging frame using the method described above for landscape enclosures.
3. Lift the front of the enclosure and set the front Portrait Bar on the level bar tube.

Portrait – Shooting UP

Left Side – Shooting Up

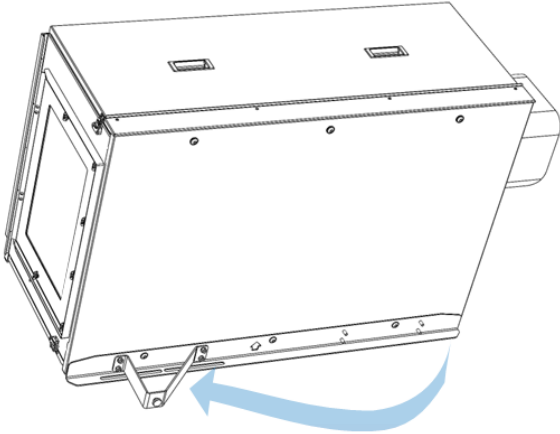

Right Side – Shooting up

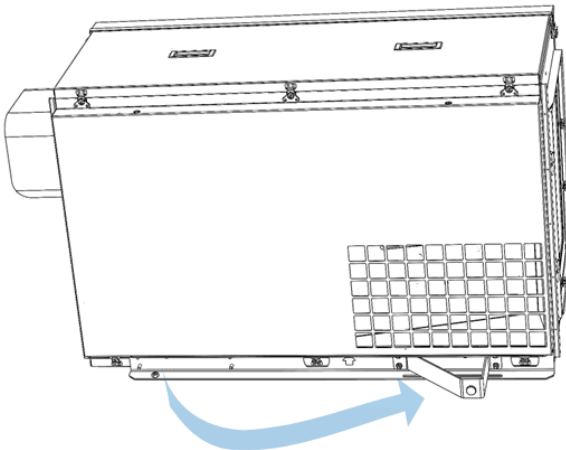

For projection UP from a frame mounted at ground level, simply flip the portrait mounts to the studs at the other end of the portrait bars, both sides.

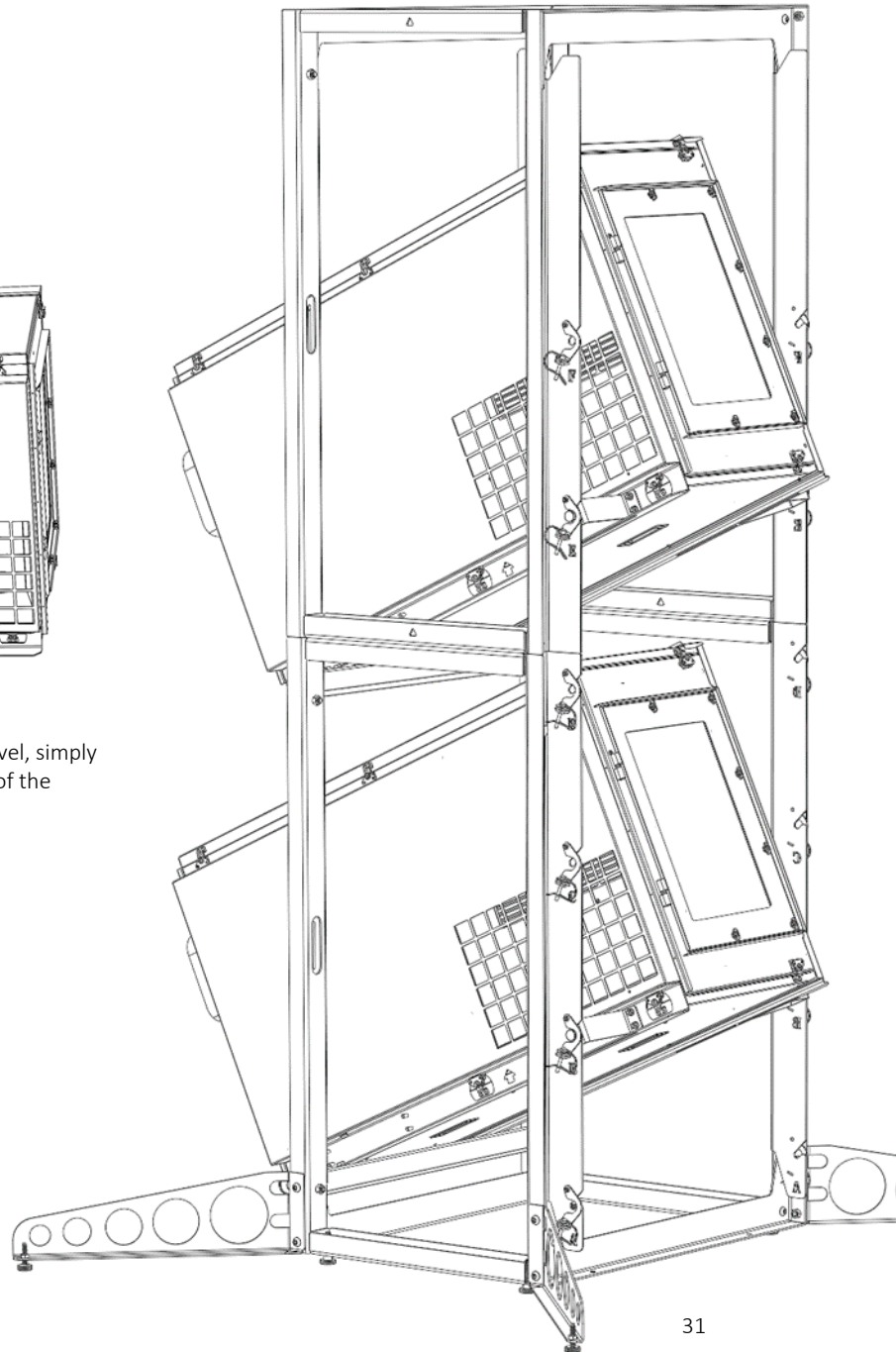

Portrait Method 2 – Horizontal

The Fly rigging Frame supports up to three Fly enclosures in portrait configuration, when the frame is *on its side*.

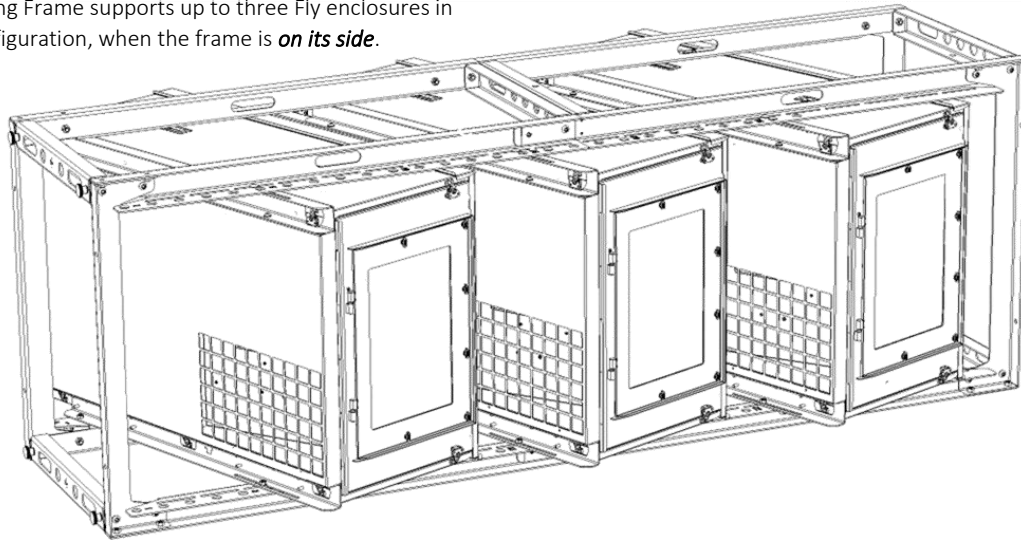

This requires the addition of three portrait mounting bars to each Fly enclosure, as shown here:

The portrait knobs should be hand-tightened to touch the side of the portrait adapter block. *Do not overtighten.*



Left Side – Horizontal

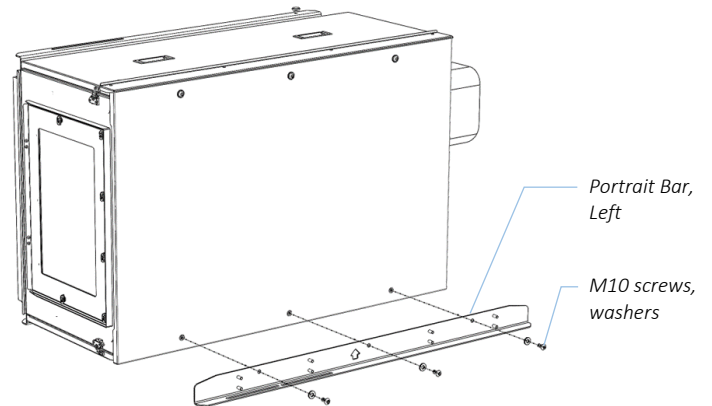

Right Side - Horizontal

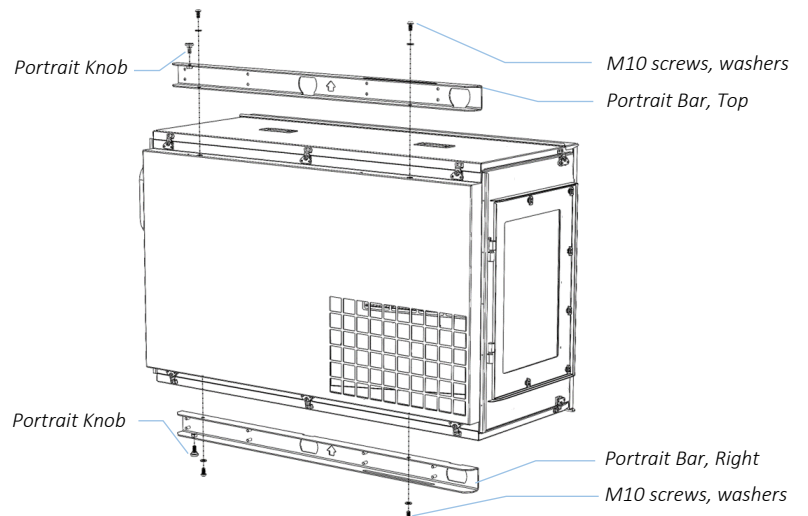

Lay the rigging frame on its side.

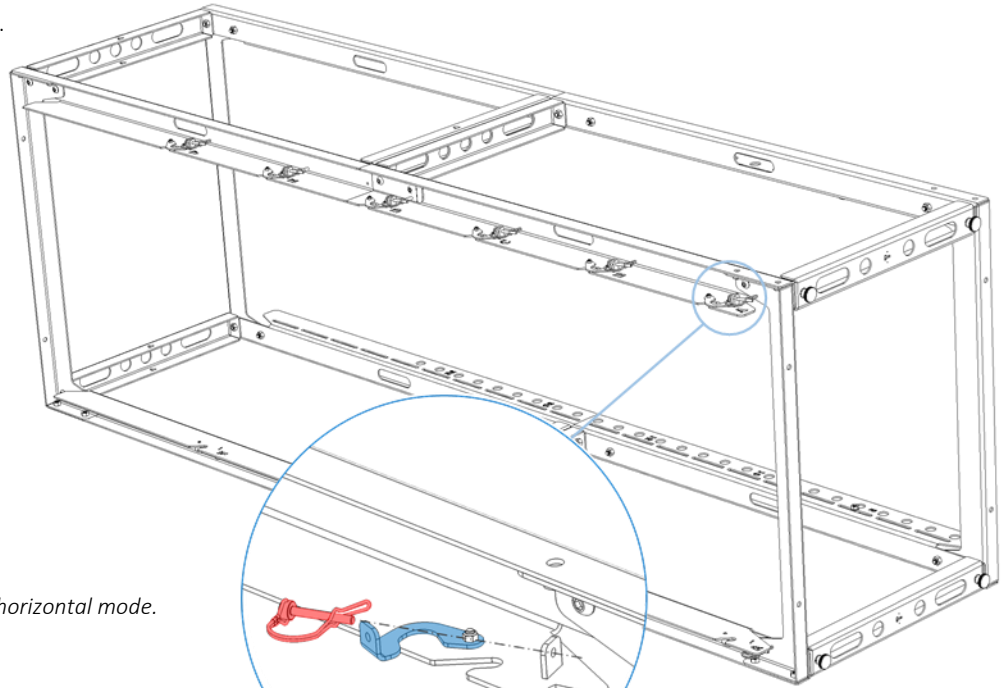

Note: level bars are not used in horizontal mode.

Open the safety hooks (top and bottom sides)

Slide the enclosure in from the back side until the portrait adapter knobs locate in the rigging frame slots.

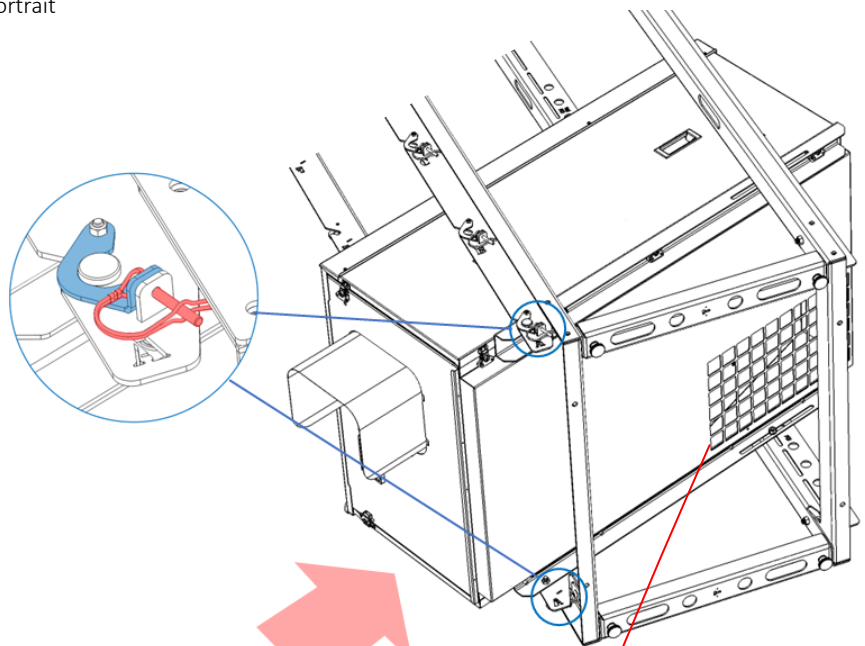

Secure the safety hook with the spring clip, **top and bottom.**

IMPORTANT: The enclosure **MUST** be aligned so that the inlet grille location is **DOWN**, as shown here.

Set the enclosure at the desired angle, then secure the front of the enclosure to the slots in the rigging frame, using the supplied stainless steel M10 carriage bolts, nuts and washers, **top and bottom**.

Add one or two more Fly enclosures, in the same manner.

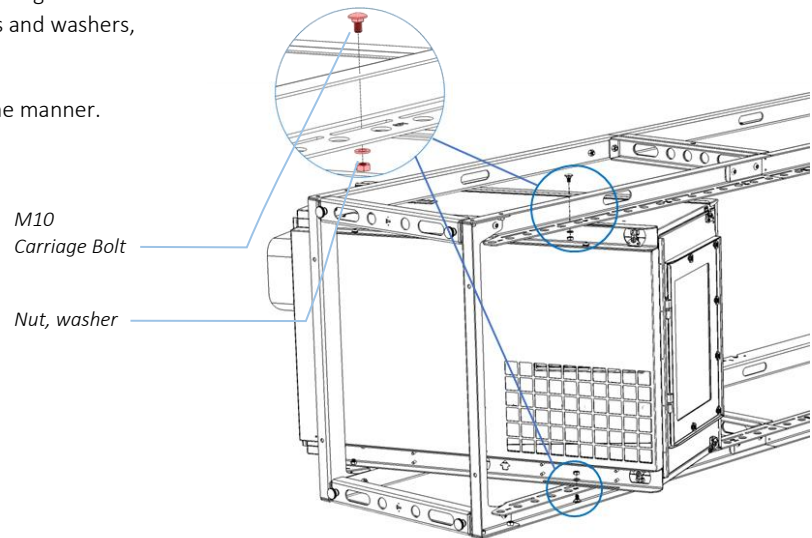

Hoisting the Assembled Rigging Frame

The fully assembled rigging frame may be safely hoisted using a crane, with suitably rated slings.

Vertical

Wrap slings under top corners.

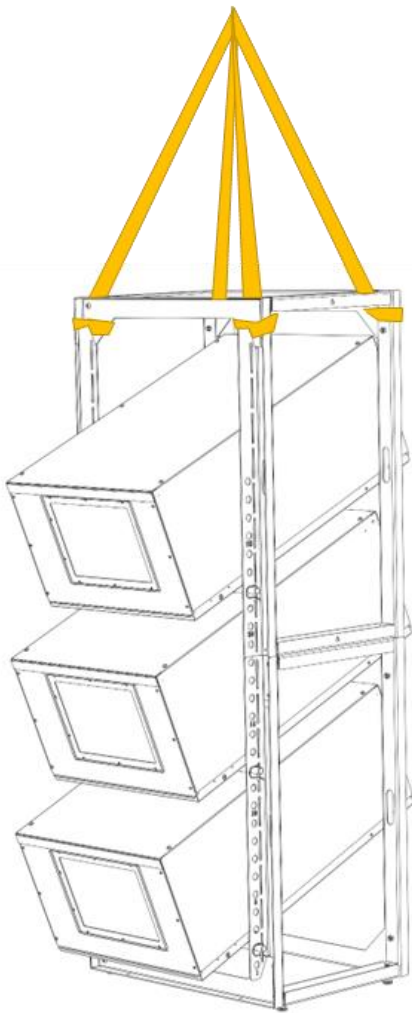

Horizontal

Thread slings through slots.

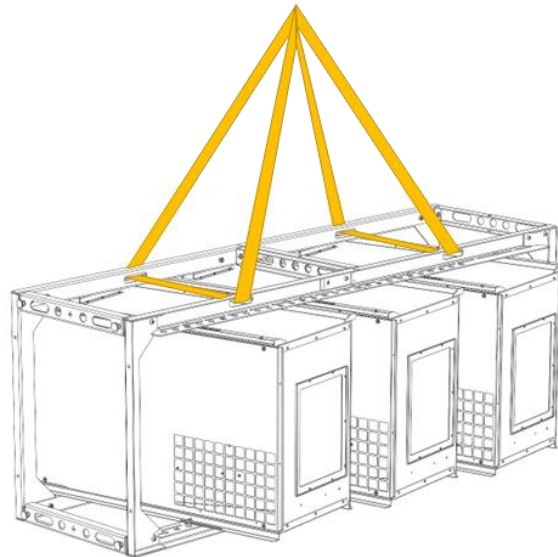

Remote Monitoring

Fly enclosures support remote monitoring over ethernet, using Tempest's TEMP protocol:

System Topology

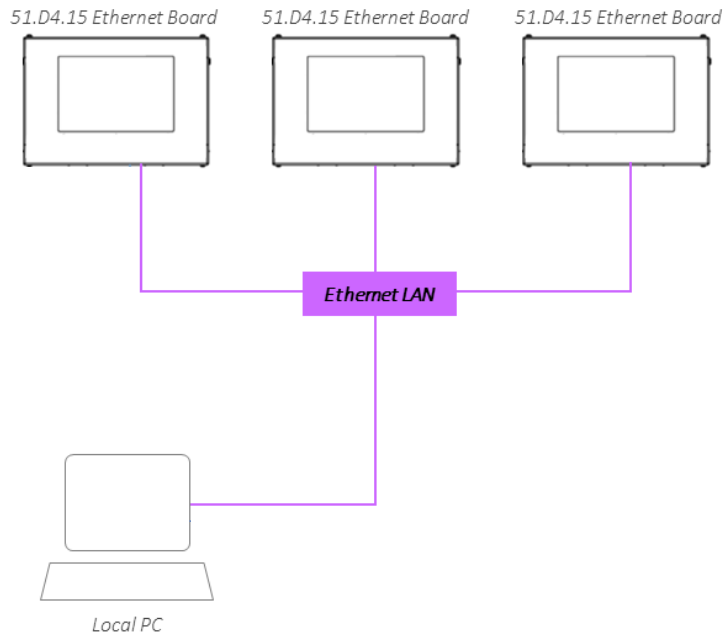

DEC4 Ethernet Adapter – 51.D4.15

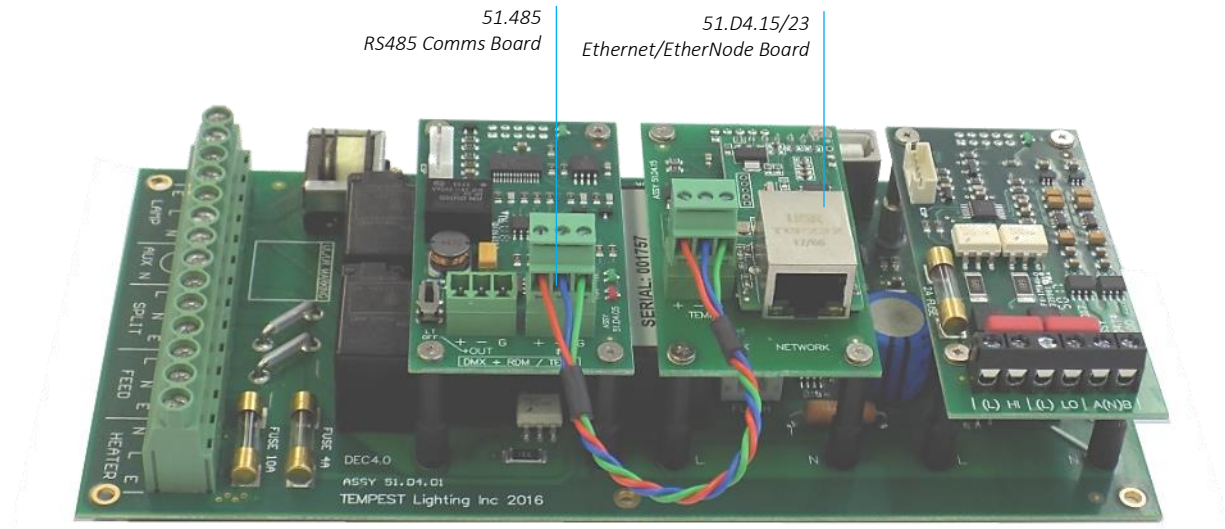

As a default, DEC4 communicates using DMX512 and RDM, over RS485.

With the addition of either Ethernet board, any DEC4 – or any group of DEC4 boards connected using RS485 – may be connected to an Ethernet network – see above.

51.D4.15 Default Configuration

The bridge module is supplied in DHCP TCP port server configuration, with all traffic on port 3308. These settings may be changed with a web browser on port 80 at the DHCP assigned address. Login to the home page using ‘admin’ for username and password.

The bridges may be discovered with a UDP broadcast on port 1500 and a payload of
(Hex) 30 31 32 33 34 35 36 37 38 39 30 31 32 33 34 35 36 37 38 39

30 31 32 33 34 35 36 37 38 39 30 31 32 33 34 35 36 37 38 39

The bridge will respond from its DHCP address

51.D4.15 Additional Support

The network IP is developed by Jinan USR, more details and software configuration utilities may be found by visiting their web site at <https://www.pusr.com>

Digital Enclosure Control

DEC4™ – that’s Digital Enclosure Control, fourth Generation – is the brain of your Tempest enclosure. It will maintain the internal environment in a comfortable temperature and humidity range, and prevent condensation – the real killer of outdoor equipment. DEC4 monitors internal and external temperature, humidity and lamp current at all times, and uses this information to control the enclosure’s lamp relay, fan(s) and heater(s). It can report back over an RS485 network, using the RDM protocol (Remote Device Management), or connect to your TCP/IP network for remote monitoring and management using Tempest’s TEMP protocol.

Typical DEC4 configuration, with Motherboard, fan control board and RS485 comms board

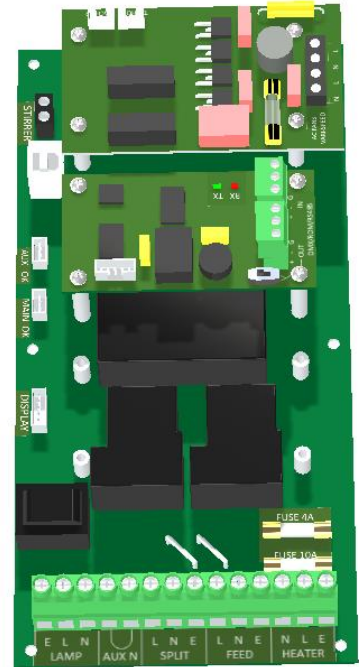

Schematic

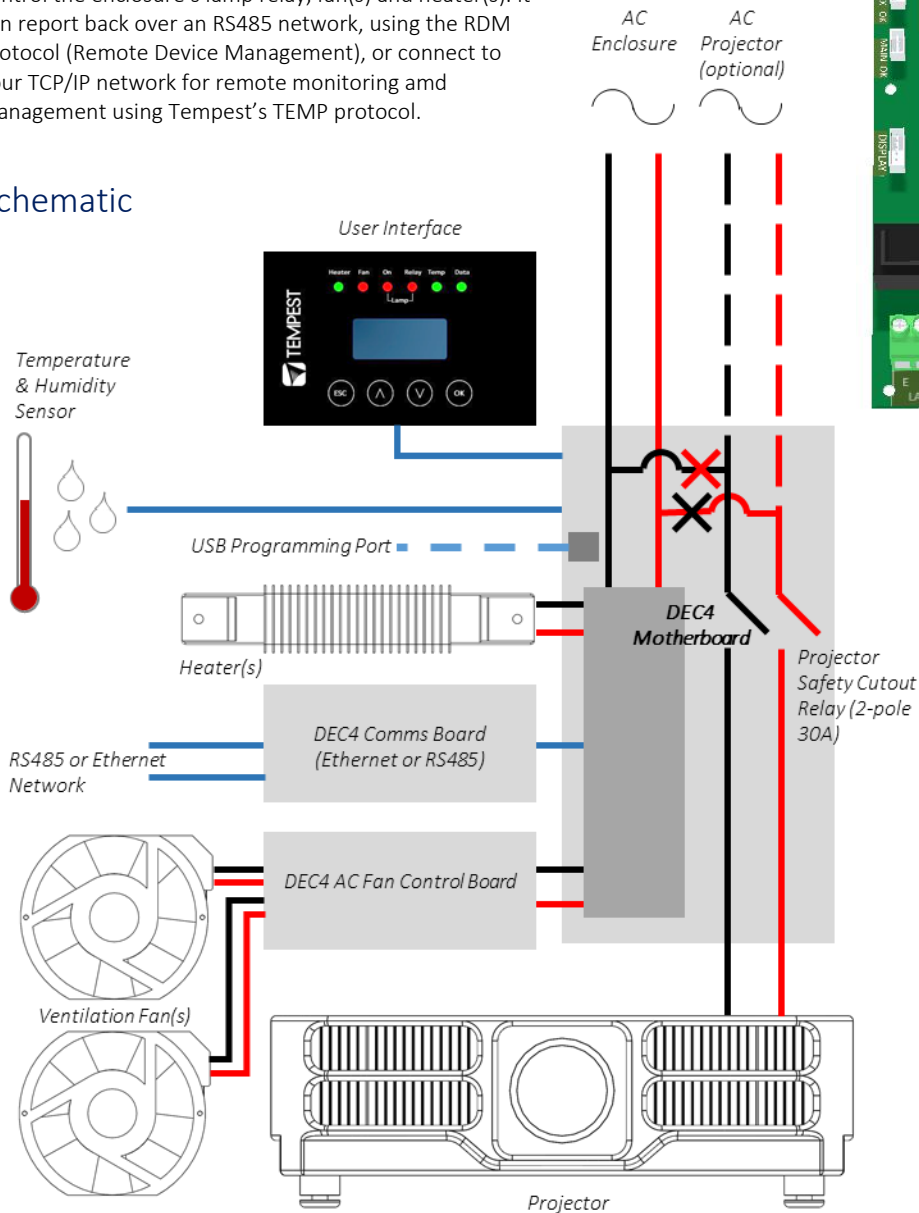

DEC4 Main Functions

Firmware Revision

This manual covers DEC4 Firmware revision 2.03.000 and higher.

To check the Firmware revision, on the User Interface menu, go to Status Display/Firmware.

1. Sense current to projector (lamp on/off)
2. Record lamp hours
3. Monitor temperature and relative humidity inside Enclosure
4. Monitor temperature outside enclosure
5. Maintain internal temperature at safe operating level
6. Maintain relative humidity within safe limits to prevent condensation
7. Isolate projector in case of unsafe temperature
8. Report status over RS485, RDM, TCP/IP
9. Maintain positive pressure (optional) 24/7 to prevent ingress of salt air and other contaminants through the exhaust path
10. Circulates air internally to prevent hot and cold spots when projector is idle

DEC 4's patented Goldilocks™ algorithm uses a combination of sensors, heaters and fans to maintain a safe operating temperature and a safe relative humidity level that will not allow condensation to take place.

As air is heated it is able to support more moisture without condensing, so Goldilocks uses heat to raise the air temperature inside the enclosure in the event that relative humidity approaches dewpoint.

DEC4 constantly monitors the following parameters:

- Projector/Luminaire current
- Line Voltage
- External Temperature
- Internal Temperature
- Internal Relative Humidity

Factory Settings – Data Modes

In most applications, DEC4 will operate correctly with its factory default settings, in Basic operating mode.

You do not need to do anything. Please skip to the next section.

- Standard default temperature and humidity settings
- DMX, RDM and Remote Monitoring disabled
- Best for standalone operation

If your needs are more complex, read on.



Hardware Indicators & Fuses

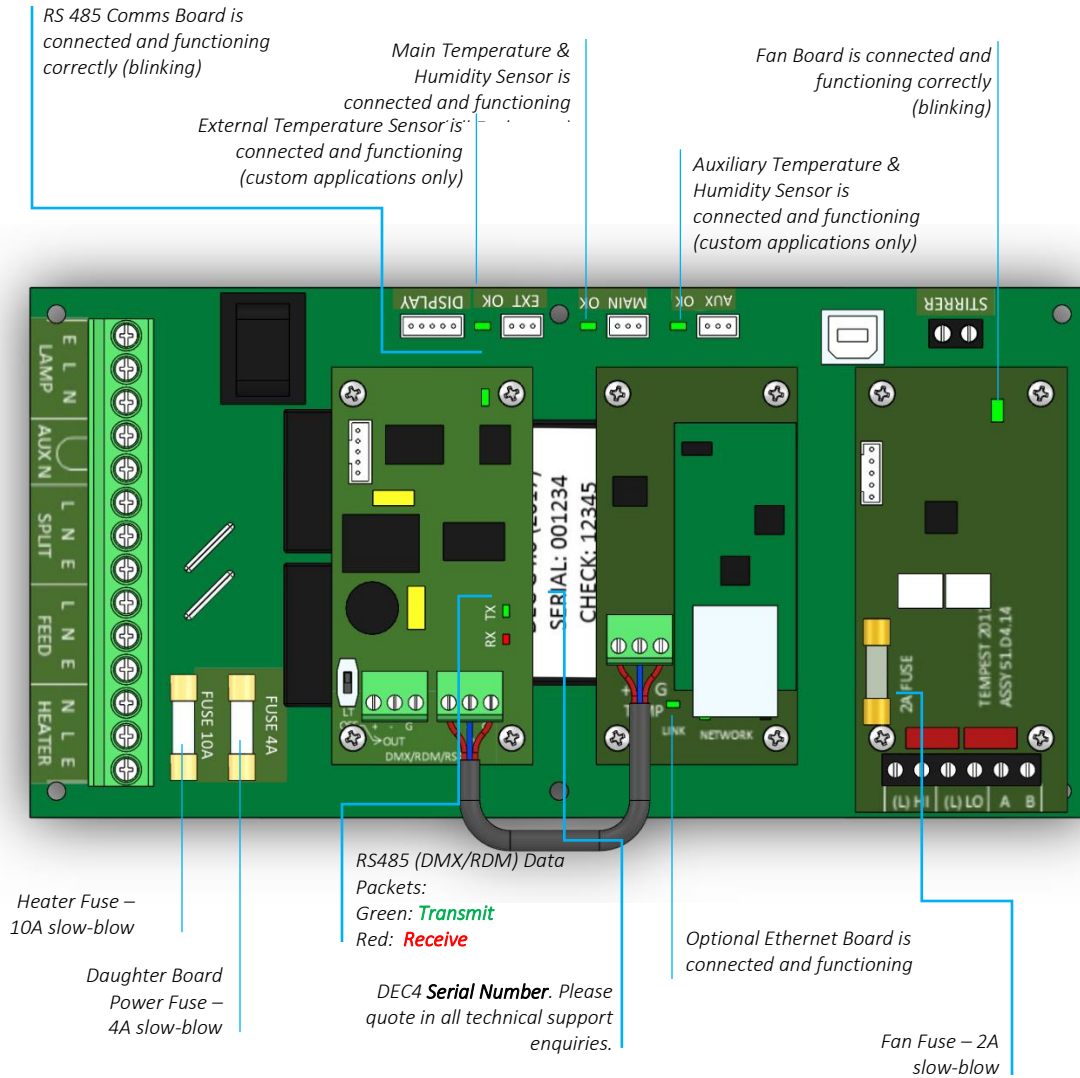

Operating Modes

RDM Only Monitor (Factory Default)

- Supports RDM monitoring over RS485 if present
- Supports TEMP monitoring if present
- RDM Status Reporting over RS485
- RDM Configuration – settings may be changed remotely or at the enclosure user interface.
- No DMX control

RDM+DMX Control

- Enclosure functions as a 1-channel DMX device, with remote control of the lamp relay
 - DMX level > 75% enables normal relay operation (normally ON)
 - DMX level < 25% disables normal relay operation (relay turns OFF)
 - This allows you to force a hard reset of the lamp relay in the event of a projector malfunction
- RDM Status Reporting over RS485
- RDM Configuration – settings may be changed remotely or at the enclosure user interface.
- Control mode is recommended for show control applications, but can be risky in live show operation, since the DMX slot used for the enclosure MUST be kept high to prevent the lamp relay from opening.

RDM+DMX Service

For trained service personnel only

- Normal operation is suspended and the enclosure functions as a 3-channel DMX device:
 - Lamp Relay (Slot 1)
 - Fans (Slot 2)
 - Heater (Slot 3)
- RDM Status Reporting over RS485
- RDM Configuration – settings may be changed remotely or at the enclosure user interface.
- ***Service mode is ONLY for troubleshooting – DO NOT use Service mode for normal operation.***

DEC4 Control Parameters

Temperature and Humidity Ranges

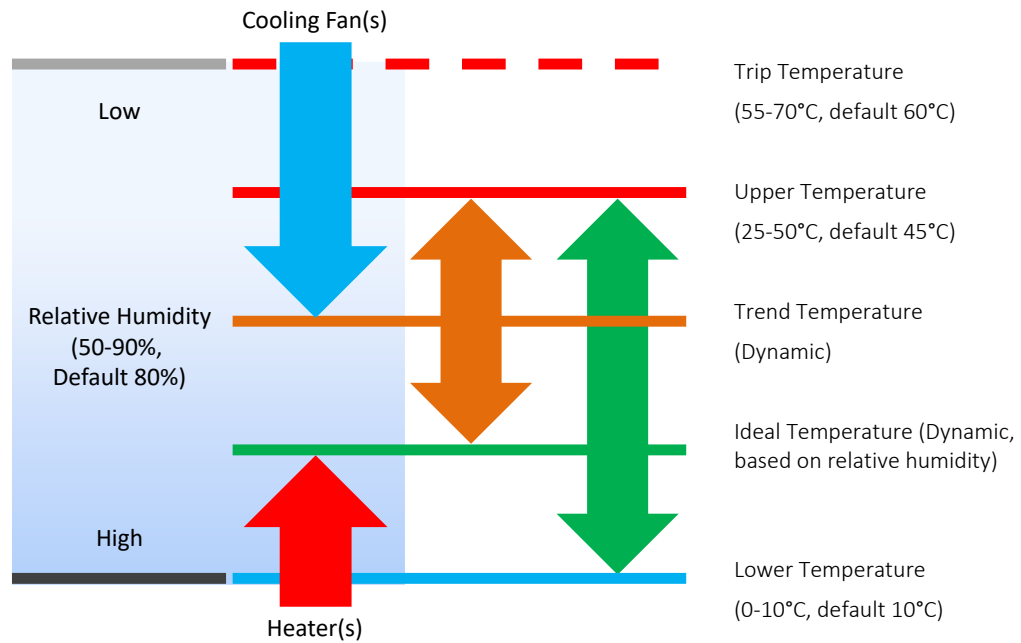

Notes:

- 1 In moving light enclosures the temperature sensor is located in the exhaust airflow. Temperatures shown may be higher than those around the projector.
- 2 We recommend using the factory default settings for several weeks or months before making any changes. In most cases they will not be necessary.

Control Interface

LED Indicators

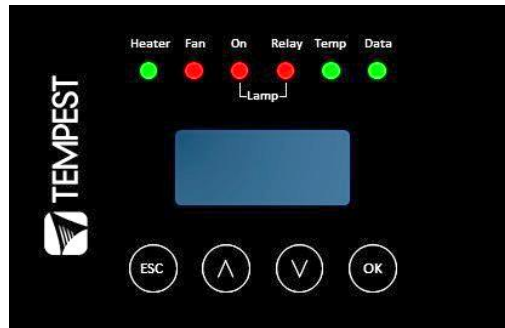

Heater	ON (Green) 	Heater is ON, to maintain lower temperature level or to prevent condensation
	ON (Amber) 	Enclosure is temporarily outside the Goldilocks zone, and DEC is working to restore it
Fan	ON (Green) 	Lamp is ON, or Temperature is HIGH and fan is cooling enclosure. OR: Lamp is OFF, and internal temperature => UPPER TEMP setting
	ON (Amber) 	Fan should be ON, but no status response received. <i>Tacit and Zen systems: check the integrity of the yellow status fan wire.</i>
	ON (Red) 	No fan detected at initialization. <i>Tacit and Zen systems, check that the yellow (status) and brown (PWM) wires are not crossed or disconnected.</i>
Lamp On	ON (Green) 	Current sensing shows lamp is ON Lamp hour counter is running
	OFF	Current sensing shows lamp is OFF Lamp hour counter is not running
Lamp Relay	ON (Green) 	Lamp relay is closed (normal) Projector power receptacle is energized
	ON (Red) 	Lamp relay is open due to over-temperature event. Projector power receptacle is isolated.
Temp	FLASHING (Green) 	Temperature is below lower temp setting
	ON (Green) 	Temperature is in normal range
	ON (Amber) 	Humidity is above target limit
	ON (Red) 	Temperature is above top setting
	FLASHING (Red) 	Temperature is above Trip level Projector power is isolated
Data	OFF	Data not used in present Mode. OR DEC4 is in RDM + DMX Control Mode and no valid data packet has been detected.
	ON (GREEN) 	Good data packet received.
	ON (RED) 	RDM + DMX Control Mode: Data Fail. A previously good data signal has failed.

User Interface LCD Display

The display on the Control display provides additional status information, depending on the operating mode:

RDM Only Monitor Mode

28 °C	47%	<i>internal temperature, relative humidity line voltage, lamp status</i>
209V	OFF	

RDM+DMX Control Mode RDM+DMX Service Mode

28 °C	47%	<i>internal temperature, relative humidity line voltage, lamp status</i>
209V	OFF	

Alternating with:

DMX: 001	<i>DMX Start Address DMX Status</i>
No DMX	

(Alternating DMX Display requires a DMX signal to be present)

Control Interface Operation

The Control Interface is normally LOCKED.

- To UNLOCK, hold **ESC** and **OK** together for **5 seconds**.
- You are now in the CONTROL MENU
- Use **↑↓** to scroll up and down the menu.
- Press **OK** to enter a menu item
- Use **↑↓** to set the item parameter, or to scroll to the next menu level.
- Use **ESC** to go BACK, or **OK** to confirm settings (**↵**).
- To exit and LOCK, hold **ESC** for 5 seconds.

Menu will time out and the display will lock after ten minutes.

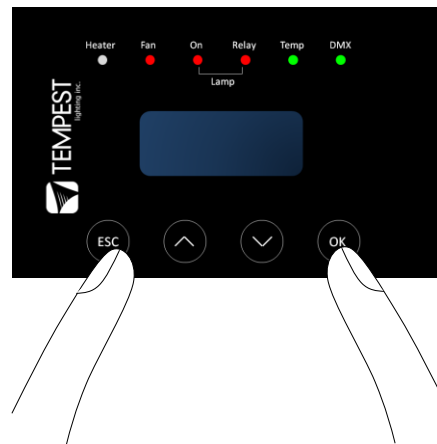

Control Menu

Set DMX Options

SET Data Mode

From the Front Panel, this menu item allows the user to check (and if necessary change) the Data mode.

RDM Only Monitor	DEFAULT	Supports RDM or TEMP if connected. No DMX Control.
RDM+DMX Service		Service mode – 3 DMX slots, starting with the DMX address set <i>Important: Please ensure that DEC4 is NOT left in Service Mode.</i>
RDM+DMX Control		DMX (set 1 address for lamp relay) plus RDM

SET DATA ADDRESS (in RDM Only Monitor, RDM+DMX Service or RDM+DMX Control Service modes)

Select a DMX starting address in the range 001 to 510

1 – Lamp Relay

In Service Mode an addition two slots are available

2 – Fan Duty Control

3 – Heater Duty Control

Note that the DMX control is designed using a SAFETY pile-on Logic. So the DMX input can only override automatic settings within safe limits.

SET DATA CURVE

DMX Curves affect the way the fixture relay is controlled in RDM+DMX Control Mode.

DMX levels are shown as %.

Response Curve 1 (default)

DMX level 0-25 Relay disabled (open)

DMX level 26-75 No change to relay status

DMX level 76-100 Relay enabled (normally closed)

Response Curve 2

DMX level 0-19 No change to relay status

DMX level 20-40 Relay disabled (open)

DMX level 41-59 No change to relay status

DMX level 60-80 Relay enabled (normally closed)

DMX level 81-100 No change to relay status

SET DATA RESPONSE

DMX Response sets a delay time before DMX Control Mode settings are acted on. Setting a response delay of a few seconds would prevent unintended fixture relay state changes in the event of a short accidental change in DMX level.

NOTE: from firmware revision 0.00.100, DEC holds last valid DMX level if DMX is interrupted.

Response Delay Values are:

No Delay (default), 1, 2, 5, 10, 15, 20, 30, 60 seconds.

Set Temp Units

Choose to display temperature values in Celsius or Fahrenheit (default Celsius)

Note that temperature settings must be entered in Celsius.

Set Temp Ranges

Set three temperature trigger points for Bottom, Top and Trip temperatures, in °C.

SET TEMP LOWER (minimum temperature to be maintained)

(default 10°C, permissible range 0-10°C).

SET TEMP UPPER (maximum desired daytime temperature)

(default 45°C, permissible range 25-50°C).

SET TEMP TRIP (temperature at which load will be isolated – see note)

(default 60°C, permissible range 55-70°C).

Note: A thermal emergency is when enclosure ventilation fails with the lamp on, in which case the temperature will rise very quickly. To avoid nuisance tripping we recommend setting a higher Trip temperature, 60°C or above.

Set Max Humidity

Sets highest desired Relative Humidity: Default 85%, permissible range 80-90%.

Note that, when the projector/luminaire lamp is OFF, the enclosure heaters will switch on to raise the temperature and lower the risk of condensation. We recommend setting the highest Max Humidity that works in your location, to avoid unnecessary heater use.

Set Lamp Options

SET LAMP ON POINT

The lamp current at which DEC detects the projector/luminaire lamp is running. Default is 1 Amp, which allows for most equipment fans and power supplies to run without changing the air in the enclosure. Lamp on point may be set in 0.1 Amp increments between 0.2 Amps and 2.0 Amps.

If the enclosure fans never turn off, the Lamp On point is probably set below the standby current draw of the projector/luminaire. Check the standby current draw on the display and set the Lamp on Current higher.

SET LAMP HEAT OFF

HEAT OFF – In normal conditions the heater will ALWAYS be disabled when the system detects the LAMP ON POINT is reached (ie: projector comes out of standby). So default is HEATER OFF at LAMP ON.

For cold weather operation (temperature < TEMP LOWER setting), the heater may operate when the lamp is on, by setting a higher current at which the heater is disabled. This may also be calculated to prevent the heater overloading the supply circuit.

For this purpose, assume that the heater will draw 5 Amps.

Range: LAMP ON, 5 – 15A

Default: LAMP ON

Example: 16A power circuit, set to 11A (16-5 = 11)

RESET LAMP HOURS

Reset each time you change the lamp in the projector.

Make this a part of your maintenance instructions.

Set Fan Function

SET FAN TEST

To test the enclosure fan(s), press [OK]

The enclosure fan will run

The Display Fan LED lights green

DEC Beeps

To stop the fan test, press [ESC]

SET FAN TYPE ID (Tacit and Zen Enclosures)

For Tacit 050-150, choose Fan Type **220**

For Tacit 210 and higher, choose Fan Type **270** (*see also SET FAN MAX DUTY*)

For Zen 1xx – 2xx, choose Fan Type 220

For Zen 3xx – 5xx, choose Fan Type 270

SET FAN RECOVERY (Tacit and Zen Enclosures)

Select a setting between 0 and 10, where 0 is fastest fan speed response and 10 is slowest.

SET FAN MAX DUTY (Tacit and Zen Enclosures)

This limits maximum speed of PWM-controlled fans. **If fan type 270 is used, MAX DUTY Should be set to 80%.**

Range: 50-100%

Default: 100%

SET FAN MIN DUTY

Tacit and Zen Enclosures (with PWM-controlled DC Fans):

In effect this is the fan speed setting. the actual range varies for each fan type:

Start with a moderate MDC value – say 60.

Test the projector, with the enclosure closed, and monitor the projector inlet temperature over the projector control system.

If the projector is running HOT, INCREASE the MDC level

If the projector is running COOL, DECREASE the MDC level

The aim is to find the sweet spot where the projector is running at an acceptable temperature over long periods, and the blower speed is no higher than necessary, to minimize power consumption and noise level.

All Other Enclosure Types (with AC Fans)

Minimum Duty Cycle setting is used in cold weather. If the actual temperature < TEMP LOWER setting, AND the projector lamp is ON, the fan will pulse under thermostatic control to attempt to maintain an internal temperature at or above TEMP LOWER. The MIN DUTY setting is the slowest fan speed.

Range: 10-100%

Default: 100%

In cold environments, set a low MDC to prevent the enclosure filling with cold air as soon as the projector lamp turns on.

IMPORTANT: Systems with Active Cooling (ActiveCool, BlizzardCool)

Minimum Duty Cycle MUST be set to 100%.

SET FAN RUN ON

Time the fan will run after system detects LAMP OFF (cooldown).

Range: 5 – 15 minutes

Default: 5 minutes

Status Display

View current status information, using the arrow keys to scroll through:

- a) Humidity – relative humidity in %
- b) Internal temperature, in degrees C or F
- c) External Temperature (custom enclosures with external temperature sensors only)
- d) PCB temperature (this will usually be significantly higher than air temperature)
- e) Voltage – line Voltage reaching the DEC

- f) Current being drawn by projector/light, in Amps
- g) Lamp Hours elapsed since last reset
- h) Firmware version
- i) UID – unique system ID number

Safe Mode

In certain circumstances, the DEC User Interface may display the message SAFE MODE. This can happen if the Humidity sensor stops reporting, or reports an extreme value, indicating the probability of a sensor error. This situation may arise either because of a faulty sensor* or in conditions of extremely high absolute humidity.



In SAFE MODE, the normal operation is temporarily suspended, and the enclosure works to return the internal environment to a condition from which normal operation may be resumed.

SAFE MODE is SAFE! It indicates that attention may be needed, but not that your equipment is at risk

Safe Mode and Sensors

** Some of the temperature/humidity sensors shipped before mid-2017 have had a limited operational life in harsher conditions. Tempest has since developed a new class of capacitive sensor that is far more resilient, especially in demanding conditions.*

The newer sensors (2018-21) have:

- a) A piece of green tape on the sensor cable
- And
- b) TEMPEST logo on the plastic sensor case

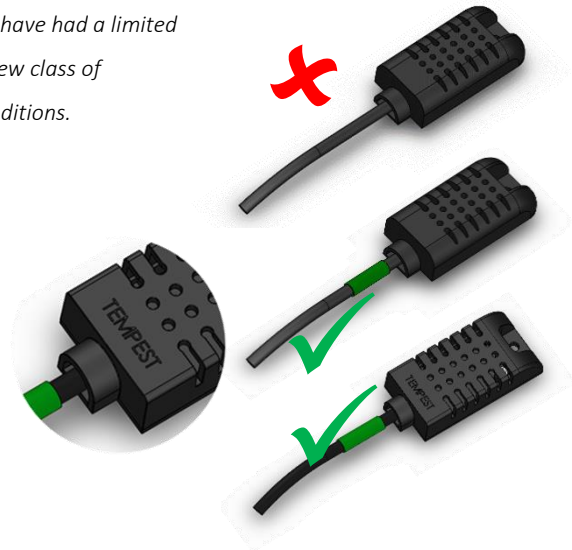

OR (from 2022):

- c) A blue tape at the connector end of the cable
- And
- d) A serial number/date code label

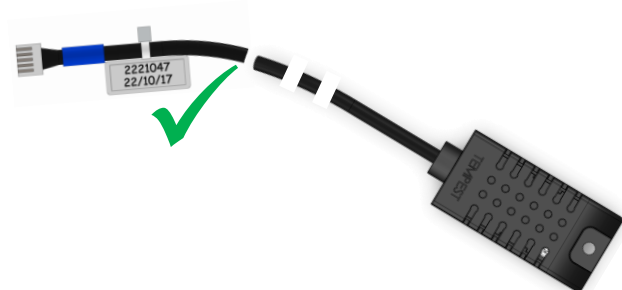

Safe Mode – What to do:

If you see **SAFE MODE** on your User Interface Display:

1. Check the temperature/humidity sensor:
 - a. Check that the sensor cable is not damaged and that it is plugged in to the header on the DEC Mother board labeled MAIN. The OK status LED should be lit.

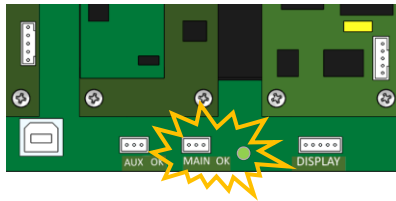

- b. If the sensor cable does NOT have a date code/serial number next to the plug, contact Tempest for a free-of-charge replacement. If you have more than one enclosure, we suggest replacing the sensors on ALL your enclosures.

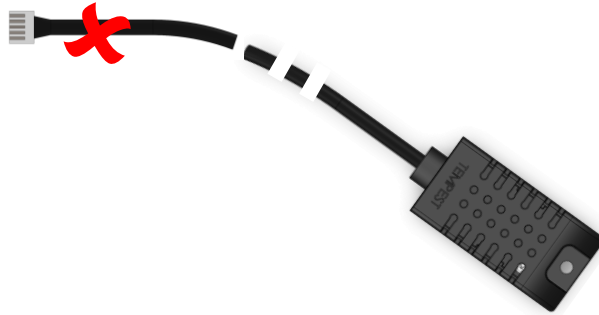

- c. Check the actual climate conditions – could the absolute humidity be close to 100%? If it is, SAFE MODE is operating correctly, and all is well.

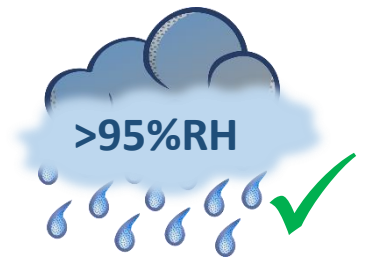

DEC4 Firmware Updates

From time to time Tempest may introduce new DEC4 firmware for feature enhancements and bug fixes. Please note that the main System Control Board (SCB) and the various optional daughter boards each have their own firmware, and it will be good practice to update all firmware in an enclosure for optimal performance and interoperability.

- System Control Board firmware may be updated DIRECTLY using JESE JUST software and a USB cable, or INDIRECTLY, over an RDM network, using JESE GetSet software and a JESE RDM-TRI interface.
- Fan board firmware is extremely simple and is unlikely to require updating.
- RS485 Board (51.485) firmware may be updated over an RDM network, using JESE GetSet software and a JESE RDM-TRI interface.

All required files are available for download at <https://www.tempest.biz/tech-support/>

Direct Firmware Update (System Control Board only)

Requirements

Windows Laptop / PC, Windows XP through Windows 10 A standard USB A to B cable



Latest version of JUST application (download from <https://www.tempest.biz/tech-support/>)

A copy of the firmware file to upload (download from <https://www.tempest.biz/tech-support/>)

Powered Target DEC4 SCB

Preliminaries

1. Power up the target DEC4 System Control Board and connect the USB Port to the PC or laptop.



2. If not already installed, install the latest version of JUST. **IMPORTANT: If this is the first time using JUST, the PC**

MUST be connected to a live System Control Board for the installation to complete correctly.

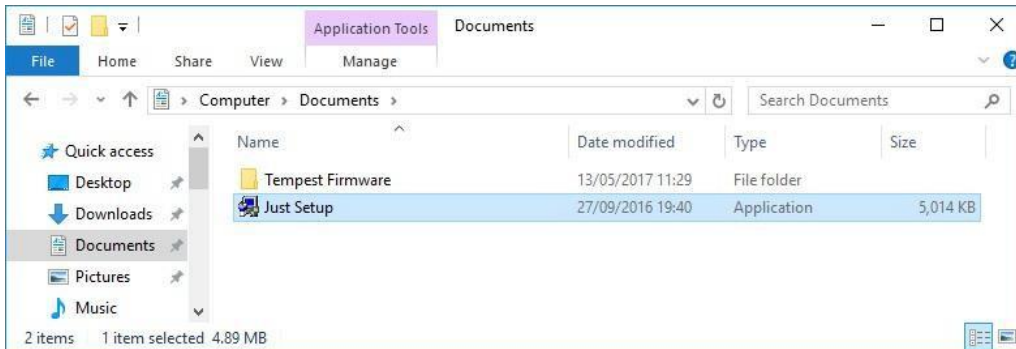

3. Run JUST and select the top left USB connection Icon. Select the DEC4 from the Connection Details option and click the connect/plug icon. Having connected, close the connection window.

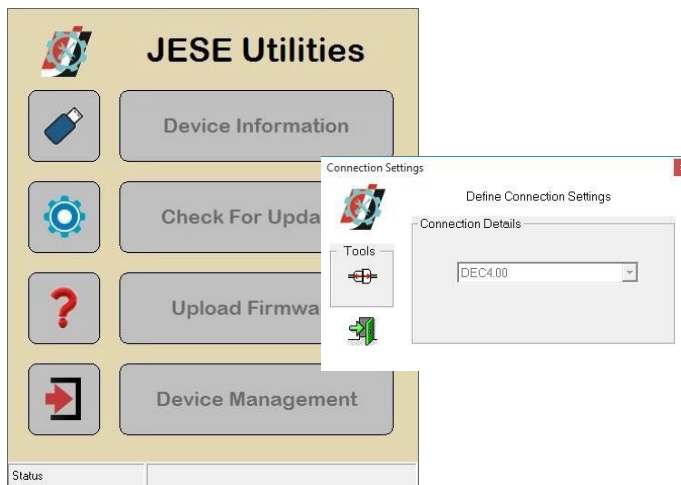

- From the main window, select the 'Upload Firmware' option. Select the file icon and navigate to the firmware file to upload

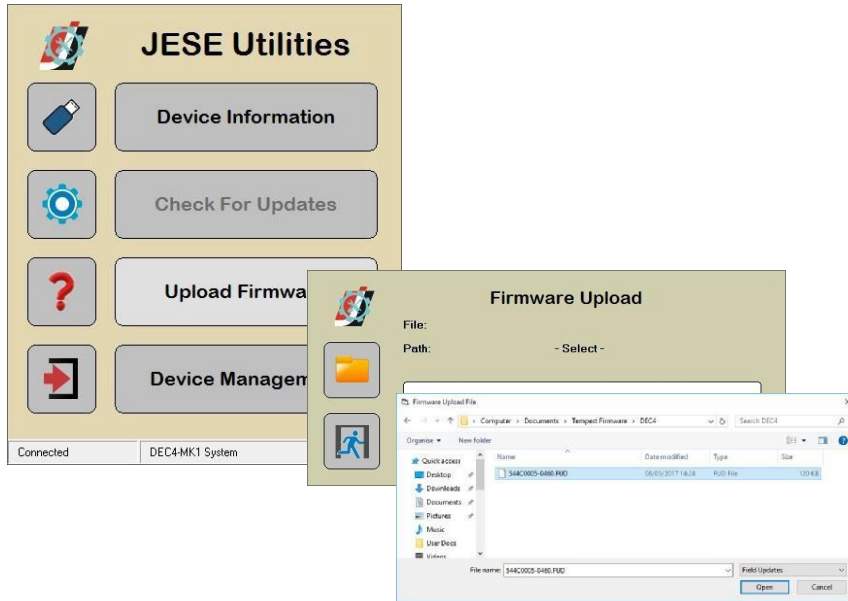

- On selection, the firmware upload will begin and run until complete.

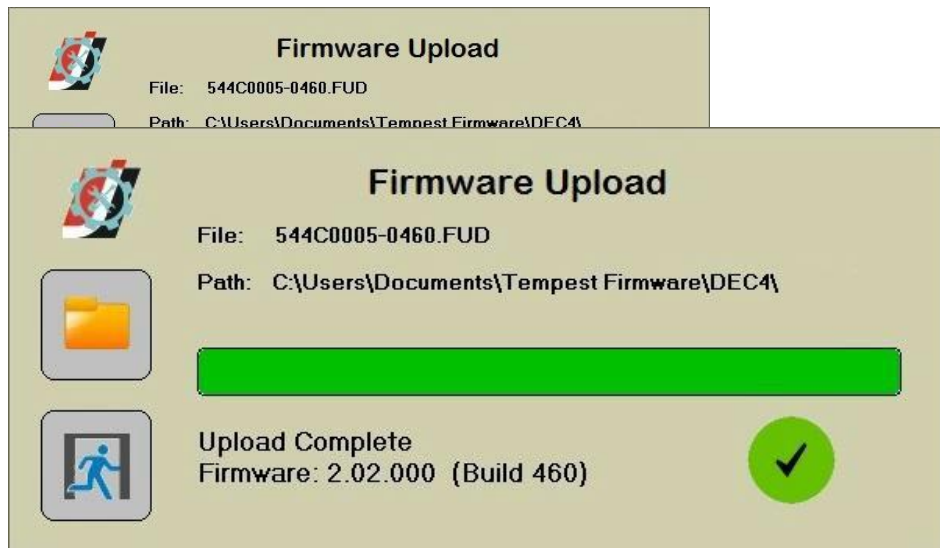

- On completion of the upload, dismiss the upload window and return to the main window.

7. The details of the SCB and firmware version may be viewed and verified by selecting the 'Device Information' option

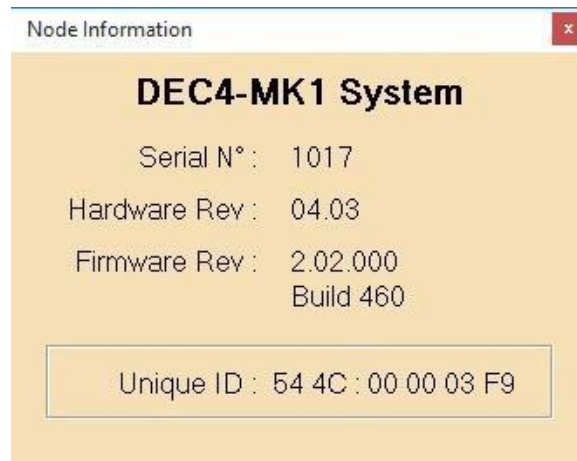

8. Close the application and disconnect the USB Cable from the SCB

- END -

Indirect Firmware Updates

Requirements

Windows Laptop / PC, Windows XP through Windows 10

A JESE RDM-TRI or RDM-TXI interface and USB connection (available from Tempest).

An installed version of the JESE GetSet RDM configuration utility.

A copy of the firmware file(s) to upload, available for download from www.tempest.biz/tech_support.

Powered Target DEC4 with 51.485 RS485 communication interface card.

Installation Procedure

1. If not already installed, install a copy of GetSet. *To ensure that the correct USB drivers are loaded, the software should be installed and the PC/Laptop re-started before connection to an RDM-TRI.*
2. If using an Asian character set, go to control panel and select Region and Language. Ensure input locale for non Unicode programs is set to a non Asian language

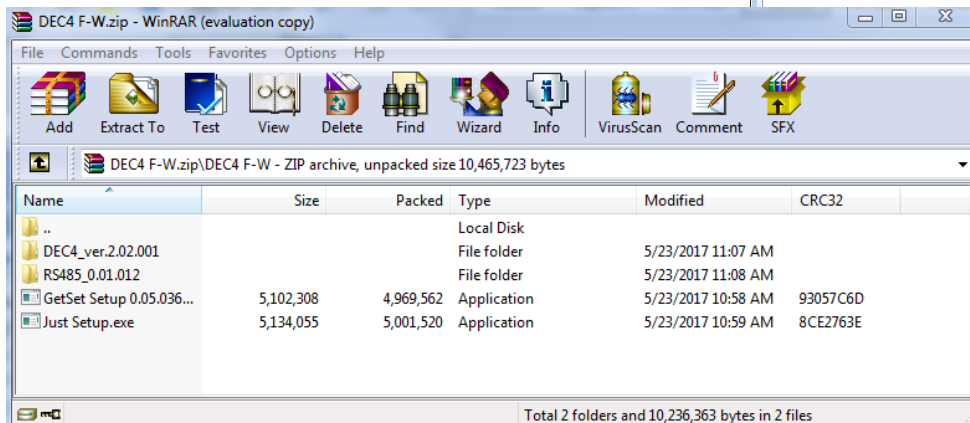
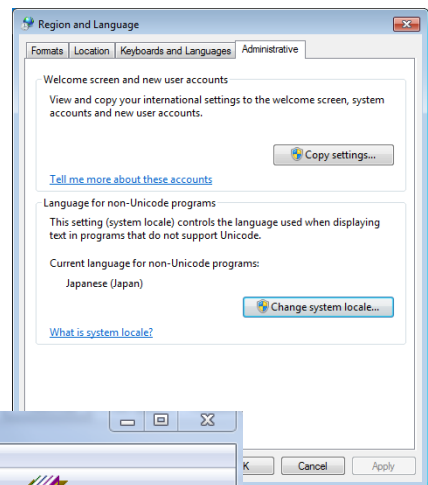

3. Connect your RDM-TRI (or RDM-TXI) in to your PC and connect to the RS485 connection on the DEC4 communications board with the fly lead, as shown below.

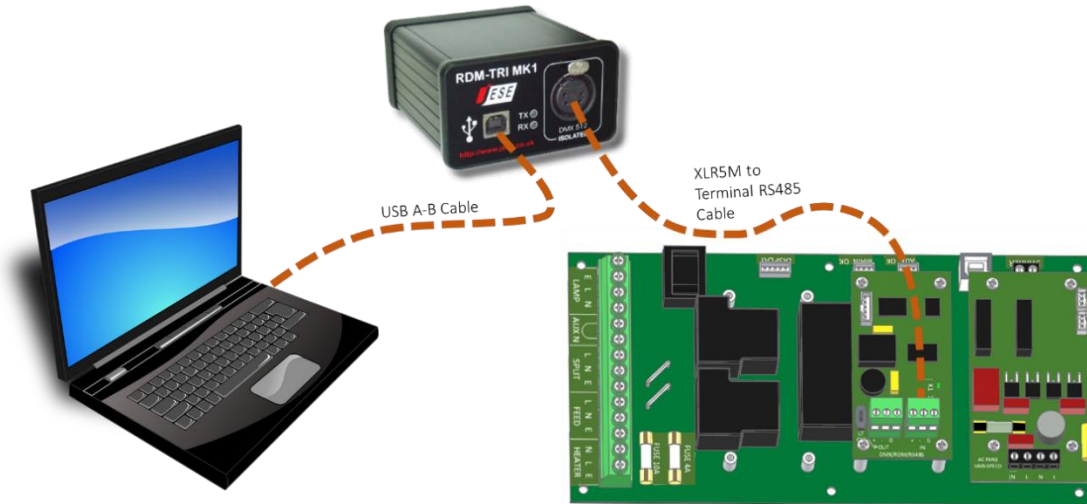

4. Power up the target SCB, ideally with mains power, or alternatively, with a USB power adaptor connected to the USB Port on the SCB.

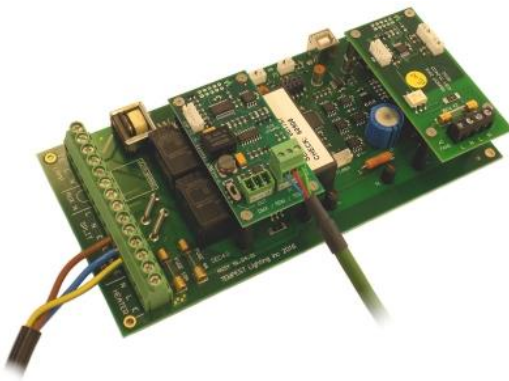

5. On older revisions of DEC Firmware, if the elected DEC 'DATA MODE' is set to 'RS485 TEMP', select 'RDM MONITOR' mode using the DEC user display. On more recent revisions of Firmware, the appropriate mode will be automatically selected.
6. Open the GetSet application, connect to the RDM-TRI and discover the DEC. To run discovery, click the Icon indicated below

- Right click on the highlighted item in the list view and select 'Reprogram' from the popup menu. This will open the firmware upload tool.

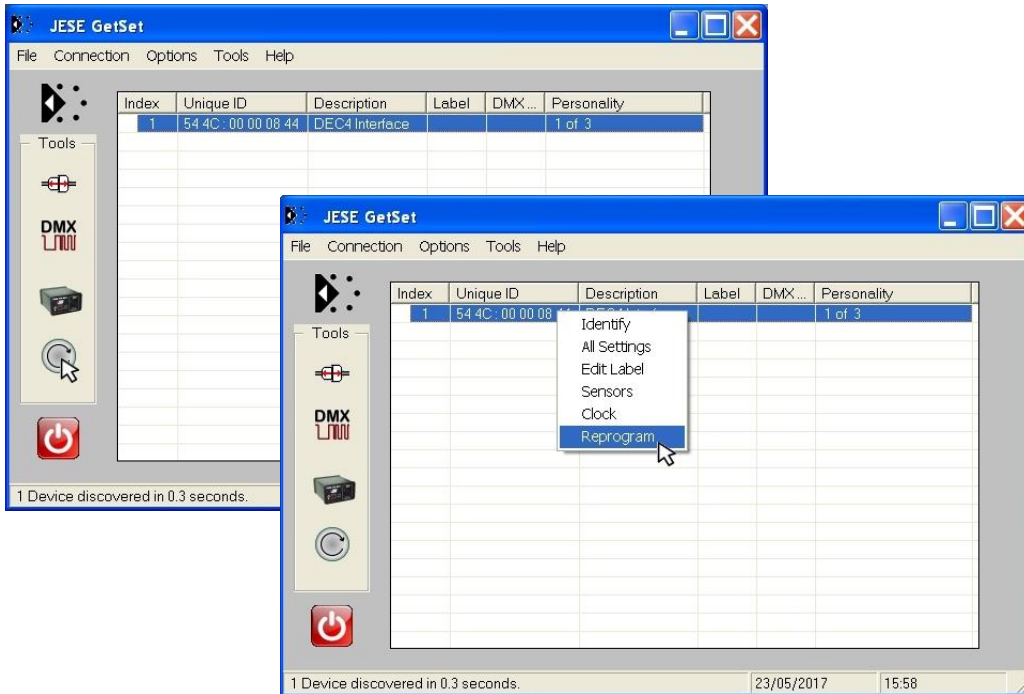

- In the Firmware upload handler, search for a file to upload by clicking the file icon. Find and select the file to load and click the Open button.

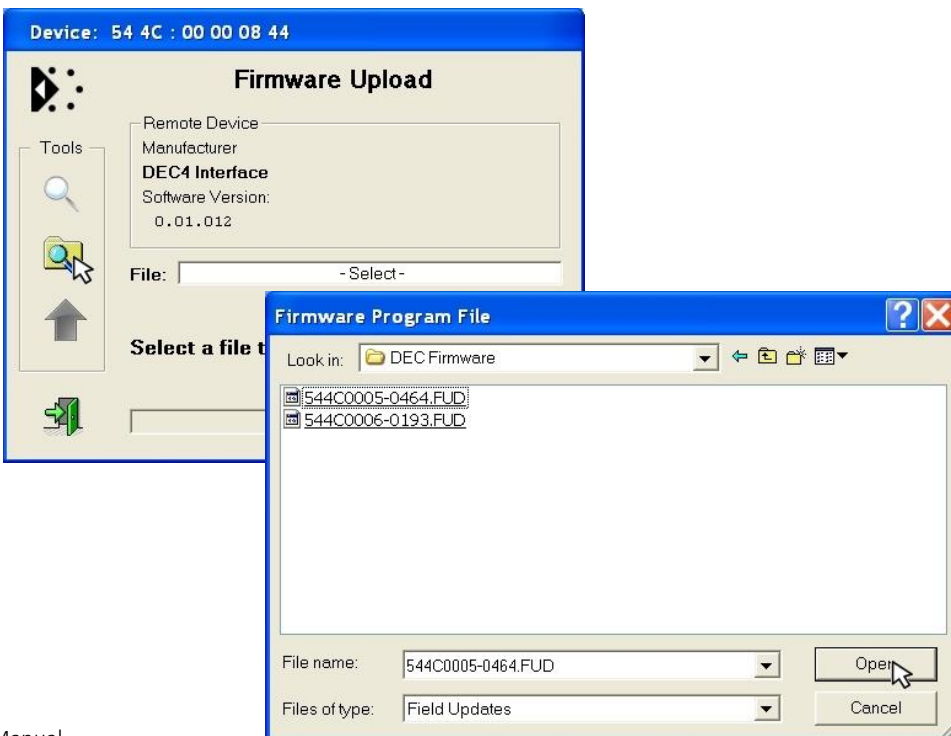

- On returning to the File upload tool window, select the green upload arrow to initiate the upload process. The upload will start.

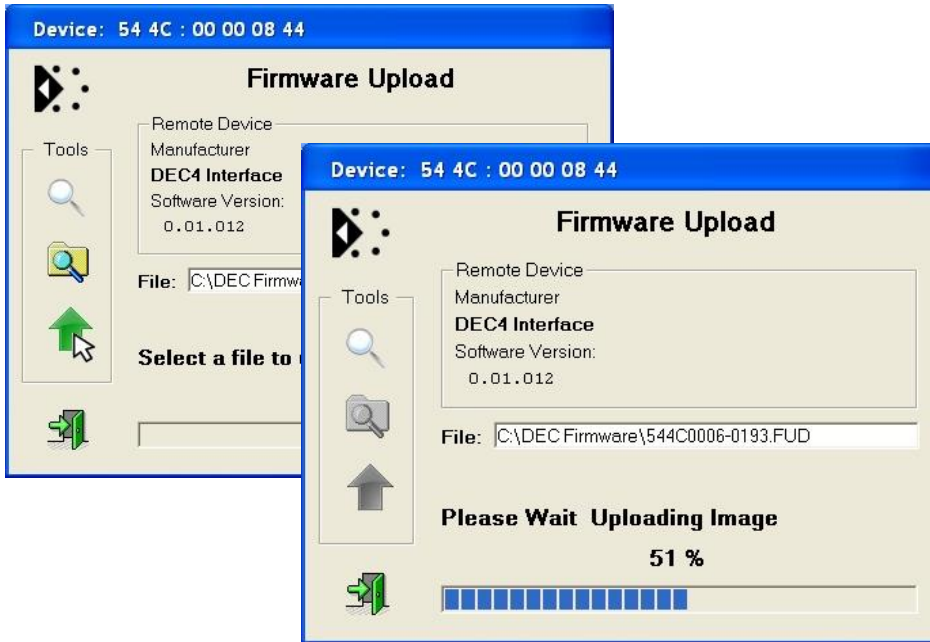

- On successful completion of upload and restart, the firmware upload is complete.

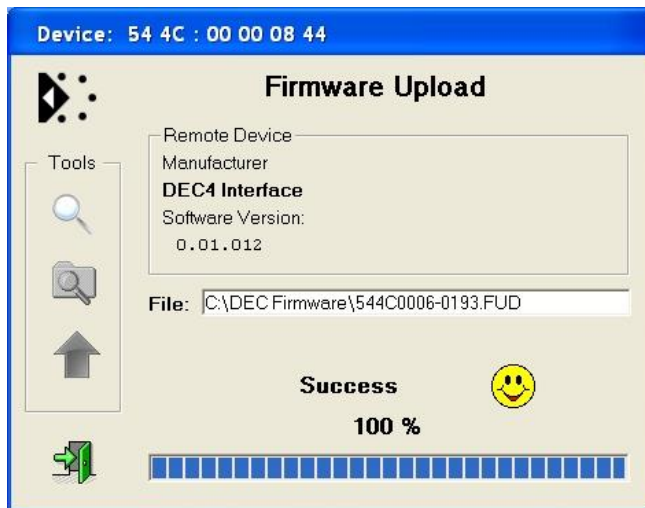

Repeat from stage 8 to 11 for each additional file to upload.

On completion of the upload, dismiss the upload window and return to the main window.

Close the application and disconnect the USB Cable from the SCB



Important:

If the Tempest enclosures are connected to an RDM interface or controller, set the DATA MODE for each enclosure as follows:

RDM MONITOR ONLY To view status information over RDM

RDM + CONTROL To monitor and over RDM and control the Lamp/Projector relays via DMX

If the enclosures are connected to an Ethernet network for monitoring using TEMP (Tempest Equipment Management Protocol) then the appropriate mode is RDM MONITOR ONLY.

Troubleshooting

Projector does not have power:

1. Check Projector power switch
2. Check projector is plugged into DEC4 projector outlet
3. Check that enclosure feed circuit is on
4. Check DEC4 User Interface leds are on. If feed circuit is on and UI leds are off, check feed wiring to DEC terminals and meter DEC4 projector outlet for power
5. If UI lamp led is on and DEC4 projector outlet is live, there is a projector fault.

Projector overheats:

1. **Is the projector connected to the DEC4 projector receptacle?** If the projector is powered independently the controller has no way to know when to turn on the exhaust fans!
2. Is the filter clogged or obstructed?
3. Check that the Fan led on the UI is on when the projector is running. If not, then the projector is probably not connected to the DEC (see 1).
4. If the fan led is on, check that the fan is running. If not, check fan wiring. If wiring is ok, fan may be faulty.
5. Check the UI display for RH (relative humidity) message. If display reads RH 5%, RH 100%, or RH####, there is a sensor fault. Contact Tempest for a replacement sensor.

Dirt/Debris inside enclosure

1. Filter is either missing or damaged?
2. Filter is not properly seated
3. Side panels or back door is not firmly latched

Water in enclosure

1. Check the drain holes in the bottom of the enclosure. If they become blocked, any water that gets in cannot escape.
2. Check seals around side panels and doors

Fan LED is on but fans do not operate

The exhaust fan is protected by a 20mm 4A slow-blow fuse on the DEC4 motherboard, and a secondary fuse on the fan board. In very exceptional cases it is possible that either fuse could fail. Check visually.

The fuse is protected with a clear resin sealant and soldered to the circuit board. With care, you can de-solder the fuse and replace it, but we recommend replacing the DEC4 motherboard to maintain the integrity of the board's conformal coating.

Heater LED is on but heater does not operate

The heater is protected by a 20mm 10A slow-blow fuse on the DEC4 motherboard. In very exceptional cases it is possible that it could fail. Check visually.

The fuse is protected with a clear resin sealant and soldered to the circuit board. With care, you can de-solder the fuse and replace it, but we recommend replacing the DEC4 motherboard to maintain the integrity of the board's conformal coating.

None of the above?

Contact info@tempest.biz

Warranty

INSPECTION/WARRANTY/RETURNS.

A. Customer, at its sole expense, shall inspect all Goods promptly upon receipt and accept all Goods that conform to the specifications or catalog. All claims for any alleged defect in or failure of the Goods or Seller's performance to conform to the Contract, capable of discovery upon reasonable inspection, must be set forth in a written rejection notice detailing the alleged non-conformity, and be received by Seller within thirty (30) calendar days of Customer's receipt of the Goods. Failure by Customer to notify Seller of the alleged non-conformity within thirty (30) days will be conclusive proof that the Goods have been received by Customer without defects or damage, and in the quantities specified on the bill of lading and shall constitute an irrevocable acceptance of the Goods and a waiver of any such claim in connection with the Goods.

B. Seller warrants to Customer only that the Goods will be free from defects in material and workmanship at the time of delivery and, subject to the exceptions and conditions set forth below, for the following period (the "Warranty Period"): twenty four (24) months from the date of shipment by Seller. Seller may provide additional years of warranty coverage beyond 24 months, at the rate of 2.5% of the net sale price per year, up to a total of three additional years' coverage beyond the standard 24 month warranty period. Seller will remedy a defect as set forth in paragraph 7 D, below, (the "Warranty"). The Warranty is subject to each of the following exceptions and conditions:

1. Customer must promptly (and in all events within the Warranty Period) notify Seller of any alleged defect in a written notice (the "Notice") which shall set forth the quantity, catalog number, finish, original purchase order number, Seller's invoice number on which Goods were originally billed and a statement of the alleged defect, along with digital photographs showing such defects where feasible.

2. The Warranty shall not apply: (i) to any claimed defect that was capable of discovery upon reasonable inspection and deemed to be waived under paragraph 7 A, above; (ii) to any Goods that have been subject to misuse, abnormal service or handling, or altered or modified in design or construction; (iii) to any Goods repaired or serviced by any person other than Seller's authorized service personnel or to Goods installed other than according to installation instructions, or (iv) with respect to normal wear and tear. Seller warrants materials and finishes to customary commercial standard and makes no warranty whatsoever to cover minor imperfections of finish not affecting the performance of the Goods.

3. Seller makes no Warranty with respect to parts or components that are not the product of Seller, and specifically makes no warranty whatsoever for equipment housed inside enclosure products manufactured by Seller.

4. The Warranty is Seller's exclusive warranty with respect to the Goods. Seller makes no warranties, guarantees or representations, express or implied, to Customer except as set forth in this paragraph 7. ALL OTHER WARRANTIES, EXPRESS OR IMPLIED, INCLUDING, WITHOUT LIMITATION ANY IMPLIED WARRANTY OF MERCHANTABILITY OR OF FITNESS FOR USE OR FOR A PARTICULAR PURPOSE, ARE HEREBY EXCLUDED AND DISCLAIMED.

C. Seller will accept the return of Goods properly rejected under paragraph 7 A, above, or as to which Notice of an alleged breach of Warranty has been timely given and such Goods may be returned to Seller, freight prepaid, but only upon Customer's receipt of Seller's written return material authorization ("RMA") and shipping instructions. The RMA shall be void if the Goods are not received within 45 days after issuance of the RMA. No deduction or credit in respect of any rejected or returned Goods shall be taken until Customer has received Seller's further written deduction or credit/authorization following Seller's inspection to confirm nonconformity or defect. Seller will charge to Customer any and all costs incurred by Seller in connection with the handling, shipping, inspection and disposition of any returned Goods that are determined by Seller not to have been nonconforming upon Delivery or as to which the warranty hereunder is not applicable.

D. UPON ANY PROPER RETURN PURSUANT TO PARAGRAPH 7C, ABOVE, WHETHER IN CONNECTION WITH A REJECTION OF GOODS OR AN ALLEGED BREACH OF WARRANTY AND BASED UPON THE CONDITIONS SET FORTH IN THIS PARAGRAPH 7, SELLER AGREES THAT IT WILL, AS THE SOLE AND EXCLUSIVE REMEDY UNDER THE CONTRACT OR OTHERWISE, FOR ANY NONCONFORMITY OR BREACH OF WARRANTY, AND AT SELLER'S SOLE ELECTION: (i) REPAIR SUCH GOODS; OR (ii) REPLACE SUCH GOODS.

NOTE: All sales are subject to Tempest Lighting, Inc. Standard Terms and Conditions (Standard Terms). In the case of any discrepancy between the foregoing and Standard Terms, Standard Terms shall prevail. Download Standard Terms [here](#).

Appendix – TEMP Protocol

AVAILABLE TO SPECIAL ORDER

Tempest can optionally provide a firmware load that facilitates TEMP over RS485, suitable for interfacing to an Ethernet adapter. TEMP is a lightweight proprietary ASCII based protocol, intended for rapid integration into management systems. With TEMP and a suitable RS485 to Ethernet adaptor connected to the DEC DMX connectors, your DEC may be configured and monitored over an IP network.

Please contact factory for ordering information.

Physical Layer

1. EITHER: Use a 51.EN Ethernet daughter board plugged directly to the DEC4 motherboard, connected to your TCP/IP network.
2. OR: Use a 51.485 RS485 daughter board on each of a number of DEC4 motherboards, and use one of the convertors listed below to bridge to your TCP/IP network.

Suitable Converters include:

<http://gridconnect.com/rs485-ethernet.html>

<http://www.audon.co.uk/lan232/ENET485-POE.html>

<http://uk.rs-online.com/web/generalDisplay.html?id=brainboxes>

Developer's Guide

Download the Developer Guide from www.tempest.biz/tech-support.