



# Typhoon

Rental &  
Staging  
Projector  
Enclosures



# Typhoon

## Rental & Staging Projector Enclosures

Typhoon is the all-weather, go-anywhere, breathe anything protection you always needed for delicate and expensive digital projectors on tours, outdoor events and those smoky TV specials where they come back full of cracked oil...

Typhoon is made from a strong aluminum chassis, with stainless steel hardware for great strength and durability in the rough-and-tumble world of rental and staging.

Typhoon models are available for most popular large-format rental projectors. Typhoon can be configured on the fly for landscape or portrait operation. Typhoon Projector Mounts are customized for each projector type, and allow the projector to travel inside the Typhoon enclosure. Set up the projector in the rental shop and save time on site! We can also design your Typhoon to house more than one projector type, to maximize your return on this investment.

Talking of investment return, Tempest features rental companies with our equipment on our web site, and since we will never rent our products, we refer all such enquiries to our Typhoon customers.

Typhoon comes with rigging points top, bottom and on both sides; a wide range of rigging accessories makes it easy to configure for any kind of event.

Typhoon's unique connector panel is totally configurable for any type of power connector and up to eleven signal feedthroughs of any type. Just tell us what you need, and Typhoon will fit in right away to your existing wiring infrastructure.



*From 2022, all Typhoons feature removable port glass frames — now you can change lenses on the fly, without moving the projector!*

*Rear view of the same enclosure, configured for portrait operation, with truss kit and Grab Handles. The exhaust and connector cowls rotate 90 degrees in portrait mode.*



*New Feature: This security ring allows you to chain the enclosure to something solid on outside jobs.*

*We get it — rental companies already have power and distribution equipment, so we'll configure your Typhoon enclosures to work with your existing cabling.*

*The cowls over the connector and exhaust ports are easily removed for access, and to rotate for portrait operation.*

### Customization

Your needs are specific to your operation - we get that. So most Typhoon orders are at least semi-custom, to fit seamlessly to our customers' needs.

We will be happy to design the perfect Typhoon for you: perhaps you need it to work with

several different projectors? No problem.

You need a special rigging accessory that we didn't think of yet? Great!

Just talk to us and we'll put together the ideal enclosure to fit *your* business.

# Typhoon

Rental &  
Staging  
Projector  
Enclosures

Tempered low-iron optical grade port glass for strength and perfect imaging

Typhoon's hydrophobic HEPA inlet filter keeps out dust, oil and salt fog.

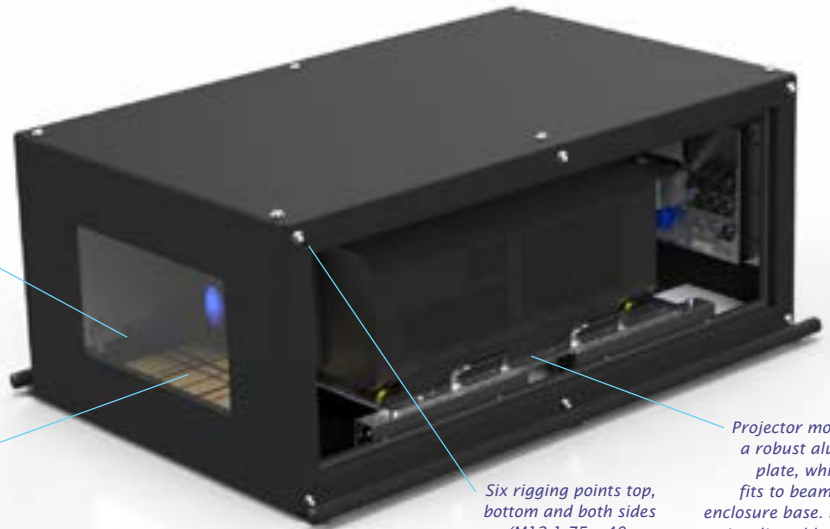

Six rigging points top, bottom and both sides (M12-1.75 x 40mm stainless steel bolts supplied)

Projector mounts on a robust aluminum plate, which then fits to beams in the enclosure base. Position is adjustable front to back to accommodate different lenses.

## Connector Panel — Power

Choose a power inlet connector type to suit your cabling (for US/Japan a separate 100-120V inlet is provided for aux equipment used inside the enclosure).

## Connector Panel — Signal

Choose up to nine Neutrik feedthrough connectors of any type, plus up to two DVI feedthroughs (total 11 connectors). Specify label text for each one and we will take care of that too!

## Internal Connections

Every Typhoon enclosure contains a C19 outlet for the projector, plus a pair of C13 outlets for any auxiliary equipment you may need to run inside the enclosure (and there's a handy rack under the projector for most commonly-used aux items - just attach them with zip ties).

And since no-one ever has IEC connectors when they need them, we include rewirable plugs for each outlet.

## 2-Speed Exhaust Fan

Set to high speed for outdoor events in warm weather, or low for indoor jobs or where the enclosure is close to the audience.

Rear Panel — Connector and exhaust cowls removed

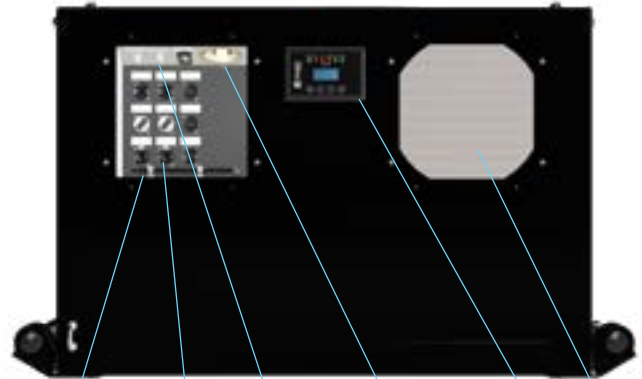

8mm Hex Key for door latches and rigging bolts — don't lose it!

Up to 9 Neutrik feed-throughs

Up to 2 DVI feed-throughs

Power Inlet Connector (and 120V Aux inlet, Americas/Japan)

User Interface

Exhaust Insect screen

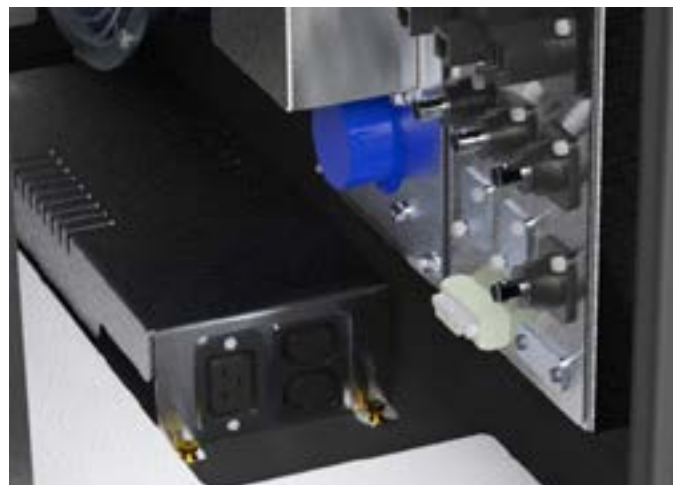

# Typhoon

## Rental & Staging Projector Enclosures

All Typhoons come with six M12 threaded sockets — one at each corner, and two midway between — top and bottom, and on both sides.

Stainless steel bolts are provided for attachment to any suitable support structure and/or any of the Typhoon rigging accessories shown here.

We are used to the weird and the wonderful, and are always happy to work on custom rigging options for you!

### Typhoon Truss Kit (54.TR.xxx)

Hang any Typhoon safely on any truss with pipe OD 2in [50].

The supplied half coupler clamps run in slots to adapt to any truss up to 24"[600].

### Stacking Kit (51.SK)

Stack two or more Typhoon enclosures of the same type using this stacking kit.

Male and female parts attach to the threaded corner holes, and are simply joined together on site using stainless steel clevis pins.

### Drop Arms Kit (54.DA)

Vary the angle of individual enclosures in a stack with these handy drop arms — requires a stacking kit.

## Rigging Options



*Stack, fly, landscape, portrait — there are so many ways to rig Typhoon enclosures, and we can help you with custom solutions too!*

## Goldilocks™

How do we keep projectors from roasting when it's 50°C and there's no shade? And prevent condensation from destroying your projector overnight?

Tempest's unique Goldilocks™ Operating System (patents pending) brings enclosure control to a new level.

Goldilocks keeps the air temperature inside your enclosure just right, removing heat from the projector when the lamp is on or when the enclosure is heated by the sun. We're changing the air about every second.

Goldilocks uses a heater to maintain a minimum temperature in cold climates.

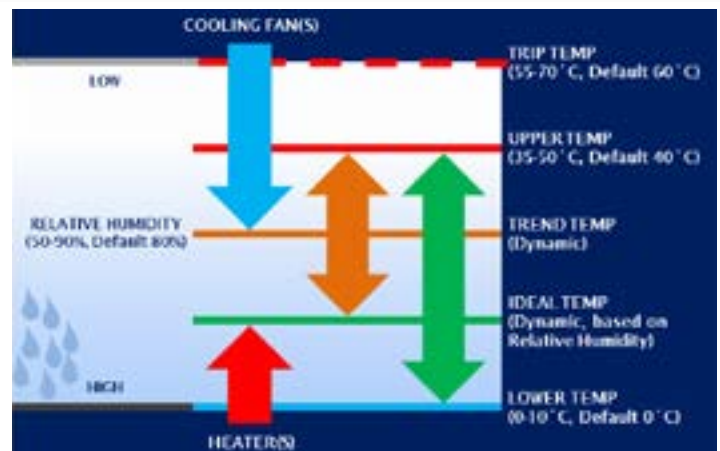

And Goldilocks tracks temperature and humidity 24/7, keeping relative humidity inside your enclosure just right by using

heaters to raise the air temperature when needed, adapting constantly to prevent deadly condensation.

# Typhoon

Rental &  
Staging  
Projector  
Enclosures

## Rigging Options

### Stacking Kit (51.SK)

Stack two or more Typhoon enclosures of the same type using this stacking kit.

Male and female parts attach to the threaded corner holes, and are simply joined together on site using stainless steel clevis pins.



### Unistrut Kit (54.UR.xxx)

Add these stainless steel Unistrut rails to any pair of rigging points for easy rigging in any orientation, using industry-standard hardware.



### Cyclovator Tilt Kit (55.C2)

Mount your Typhoon enclosure on a Cyclovator for quick and easy tilt adjustment up to 60° up or down - so handy when you don't know the tilt angle until you get to the job site...

(Cyclovator requires the enclosure to have a Unistrut kit (54.UR.xxx))



# Typhoon

Rental & Staging Projector Enclosures

Tempest System Manager is a Windows app running on a local PC connected to your enclosures over a local area network.

TSM discovers any Tempest enclosures present on the network at initialization, and monitors system attributes in real time, including lamp, fan and heater status, temperature, relative humidity and more.

TSM may also be used to upload firmware updates to enclosure controllers over the network, without having to visit each enclosure.

The TSM license includes 12 months unlimited user support from Tempest electronics partner JESE, and continuing support is available for a modest annual fee.

### Monitoring Connections

There are two ways to connect enclosures to the TSM PC:

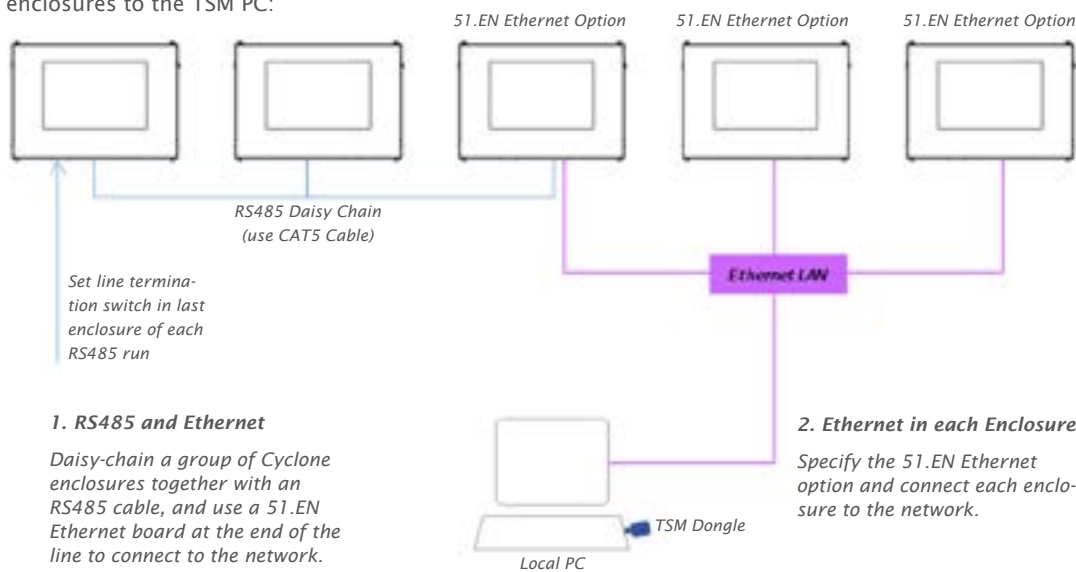

#### 1. RS485 and Ethernet

Daisy-chain a group of Cyclone enclosures together with an RS485 cable, and use a 51.EN Ethernet board at the end of the line to connect to the network.

#### 2. Ethernet in each Enclosure

Specify the 51.EN Ethernet option and connect each enclosure to the network.

# Tempest System Manager

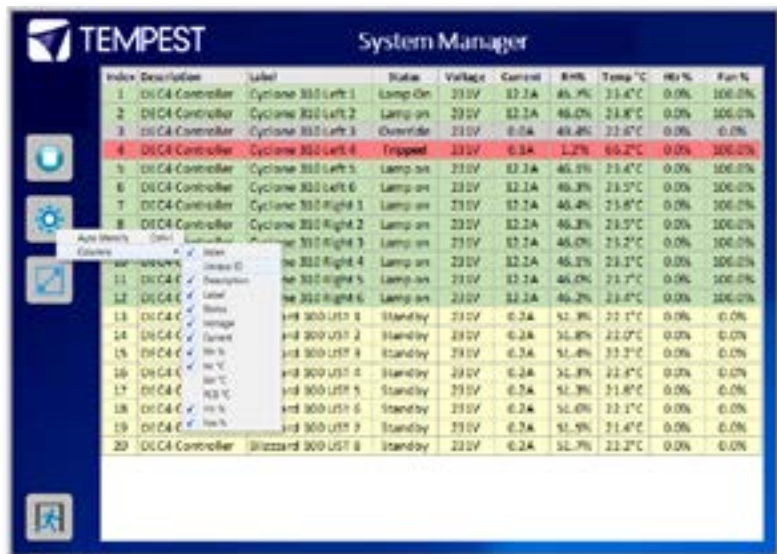

### TSM Model Numbers

- 51.TSM.10 Up to 10 enclosures
- 51.TSM.25 Up to 25 enclosures
- 51.TSM.50 Over 25 enclosures

# TEMP Protocol



Tempest also publishes a simple protocol for use by integrators wishing to monitor enclosures over an existing control network.

Connection options are the same as for System Manager.

Download the TEMP Developer Guide [here](#):

## Enclosures

Typhoon Enclosure Dimensions <sup>1</sup>		Enclosure								Shipping							
Model	Typical Projectors <sup>2</sup>	L (cm)	W (cm)	H (cm)	Kg	L (in)	W (in)	H (in)	Lb	L (cm)	W (cm)	H (cm)	Kg	L (in)	W (in)	H (in)	Lb
54.200	Epson EB-PU 22xx	86	86	46	39	34	34	18	86	107	107	71	70	42	42	28	154
54.202	Panasonic PT-RQ25K, DPI M-Vision 23K	112	76	46	39	44	30	18	86	132	97	71	70	52	38	28	154
54.204	Christie M4K-25	117	76	51	47	46	30	20	104	137	97	76	78	54	38	30	172
54.210	Panasonic PT-RZ21K, Barco G100	127	86	51	47	50	34	20	104	147	107	76	78	58	42	30	172
54.250	Epson L-30000	127	94	51	49	50	37	20	108	147	114	76	80	58	45	30	176
54.305	Panasonic PT-RQ35K, RZ34K, Barco UDM	132	81	61	49	52	32	24	108	152	102	86	80	60	40	34	176
54.310	Barco UDX 40K	137	86	61	66	54	34	24	145	157	107	86	97	62	42	34	213
54.314	Christie Griffyn 32K	147	86	61	66	58	34	24	145	168	107	86	97	66	42	34	213
54.322	DPI Titan Laser 37K	142	94	61	76	56	37	24	167	163	114	86	107	64	45	34	235
54.514	Christie Griffyn 50K	147	94	61	76	58	37	24	167	168	114	86	107	66	45	34	235
54.522	DPI Insight 8K 37K	163	94	71	74	64	37	28	164	183	114	97	115	72	45	38	253
54.525	Panasonic PT-RQ50K	163	91	66	74	64	36	26	164	183	112	91	115	72	44	36	253

## Options

54.TI	Any Typhoon	Thermal Insulation Lining
54.GH.xxx	Typhoon xxx	Pair of Grab Handles
51.SK	Any Typhoon	Stacking Kit
54.DA	Any Typhoon	Pair of Drop Arms (requires 51.SK)
54.TR.xxx	Typhoon xxx	Typhoon Truss Kit
54.UR.xxx	Typhoon xxx	Pair of Unistrut Rails
51.D4.15	Any Typhoon	Ethernet Comms Board (TEMP)
51.D4.23	Any Typhoon	Ethernet Comms Board (TSM)
51.TSM.xx	Any Typhoon	Tempest System Manager
54.CF	Typhoon 150 and up	Replacement Rubber Connector Flap
54.CF.100	Typhoon 100	Replacement Rubber Connector Flap
51.HF.15	Typhoon 150 and up	Replacement Inlet Filter (15in)
51.HF.11	Typhoon 100	Replacement Inlet Filter (11in)
<b>Power Inlet Options</b>		
L6-20	US/NEMA	20A 208V (2 hots)
L21-20	US/NEMA	20A 208V (2 hots + N)
L6-30	US/NEMA	30A 208V (2 hots)
L21-30	US/NEMA	30A 208V (2 hots + N)
IEC320-C20	International	20A 230V
IEC309-16	International	16A 230V
IEC309-32	International	32A 230V
Custom	Any	Consult Factory
Signal Feedthroughs - see Typhoon Configurator		

<sup>1</sup> All Typhoon Enclosures are custom or semi-custom. Please consult factory for details. Dimensions shown here are approximate, pending submittal drawings for each sale.

<sup>2</sup> If your projector is not shown here, please contact Tempest.

All Schedule B Export Code: 9405.99.0000

All sales are subject to Tempest Lighting, Inc. Standard Terms and Conditions, available for download at [www.tempest.biz](http://www.tempest.biz).



# Typhoon Configurator

Please complete this form and email to us at [info@tempest.biz](mailto:info@tempest.biz)

Name *		
Company *		
Email *		
Phone		
Projector & Lens Make/Model #	Projector: *	Lens: *
Typhoon Model *	54.	Quantity
Destination Country *		
Required by (date) *		
Supply Voltage *		

Options			
Thermal Insulation	Qty	No	
Grab Handles	Qty	No	
Truss Kit	Qty	No	
Positive Pressure	Qty	No	
Cyclovator	Qty	No	
Angle Mount Kit	Qty	No	
Stacking Kit	Qty	No	
Drop Arms Kit	Qty	No	
Unistrut Kit	Qty	Mounting	No
Ethernet Comms	Qty	Type	No
Spare Inlet Filter	Qty	No	

Projector Power Outlet (all types include IEC 60320 C13 Aux Power):

Select Type:

Custom:

Color, standard	Light Bronze	Black	White
Color, custom	Custom, RAL #		
Gloss levels higher than 30% may show up weld marks. Tempest accepts no responsibility in this event.	Gloss Level	%	
	Salt Fog Primer:	Yes	No

Signal Connectors:		
Connector Types (up to six Neutrik D-style feedthroughs)	Position: (indicate type)	Text Label (12 characters Max)
Types: A: Ethercon B: OpticalCon C: HDMI D: Displayport E: BNC F: XLR5M G: XLR5F H: 3.5mm Jack J: Blank K: DVI G: Other:  LAYOUT 1 2 3 4 5 6 7 8 9 DVI1 DVI2	1	1
	2	2
	3	3
	4	4
	5	5
	6	6
	7	7
	8	8
	9	9
	DVI 1	DVI 2

Custom Requests:

Factory Use Only:	SO #:	Date:
Electrical:	IEC	NEMA Wiring p:
Test:	Function	Projector
Hardware Kit:		

