



Blizzard

Outdoor
Projector
Enclosures
5-15K



Blizzard

Outdoor Projector Enclosures

Blizzard is the world's most popular midsize outdoor projector enclosure family for permanent installation in any climate, for video mapping, outdoor attractions, advertising and outdoor movies.

Now Blizzard comes with all the new features you've asked us for:

- *Optional Projector Tray slides out either side for easy installation and service access*
- *Tabletop or ceiling projector mount*
- *Stackable*
- *Loads of rigging accessories*
- *Optional Ethernet-based monitoring*
- *New midsize 52.125 models for wider midrange projectors*

All Blizzard models feature Tempest's patented Digital Enclosure Control system (DEC4™), now available with optional remote monitoring over your TCP/IP network or with RDM over RS485.

Blizzard models come in four sizes, and three configurations, to suit any outdoor projection application:

Landscape

The standard configuration — projector may be configured tabletop or ceiling style, with your choice of fixed or sliding projector mount.

Portrait

Blizzard portrait versions are available in all four sizes. Specify projector and lens type when ordering.

Ultra-Short-Throw

Blizzard is ready for the UST revolution — now you don't need to own the plot across the street to project on the front of your building! UST models may be configured to project either up or down, for ground or roof-level installation. Specify projector and lens type when ordering.

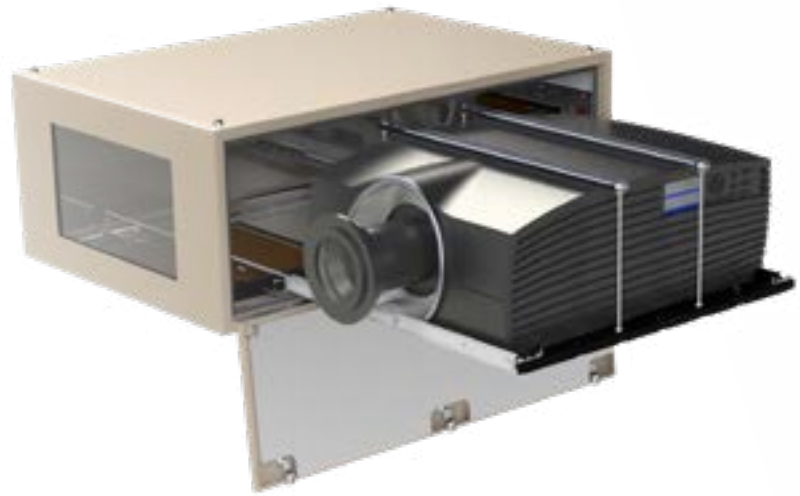

Blizzard 52.150.LS with projector slide. Use 52.150 models for most projectors 12-15,000 ANSI lumens.

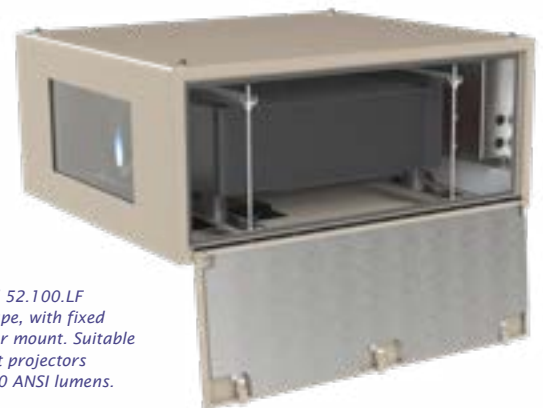

Blizzard 52.100.LF Landscape, with fixed projector mount. Suitable for most projectors 8-10,000 ANSI lumens.



Blizzard 52.050.P Portrait enclosure, for most projectors 4-7,000 ANSI lumens that allow portrait orientation.

Tip: most of the enclosures shown here are in Tempest's standard light bronze finish, but black, white, or any RAL color are available to order.



Blizzard 52.150.U Enclosure for most projectors 12-15,000 ANSI lumens fitted with Ultra-Short-Throw lenses.

Blizzard UST enclosures may be installed to project either up or down.

Blizzard

Outdoor
Projector
Enclosures

Landscape

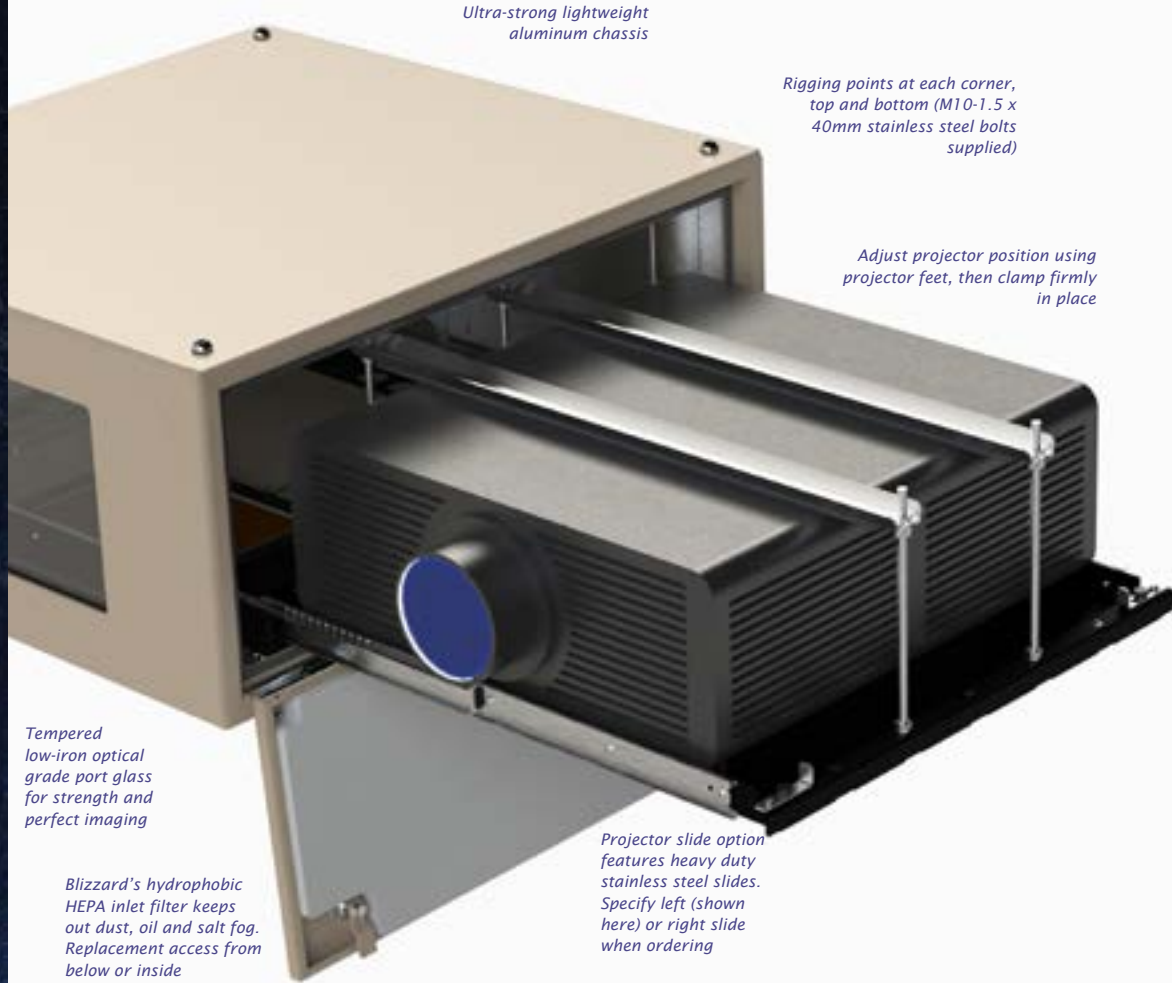

Ultra-strong lightweight aluminum chassis

Rigging points at each corner, top and bottom (M10-1.5 x 40mm stainless steel bolts supplied)

Adjust projector position using projector feet, then clamp firmly in place

Tempered low-iron optical grade port glass for strength and perfect imaging

Blizzard's hydrophobic HEPA inlet filter keeps out dust, oil and salt fog. Replacement access from below or inside

Projector slide option features heavy duty stainless steel slides. Specify left (shown here) or right slide when ordering



Powerful AC exhaust fan runs when the controller detects the projector lamp is on, or if internal temperatures rise during the day.

The Exhaust Cowl's integral insect screen keeps rain — and bugs — away from your equipment. For additional protection against saline air and other pollutants, specify Blizzard's Positive Pressure option. (52.PP)

Lockable hinged side doors for easy access and security

DEC4 Enclosure Control with patented Goldilocks™ OS and remote monitoring options

Large, easy-access wiring compartment for easy installation, with choice of wiring knockouts on the back and bottom surfaces

Removable security panel protects user interface

DEC4™ User Interface, for customized setup and system monitoring. May be monitored remotely with optional comms card

Blizzard

Outdoor
Projector
Enclosures

Portrait



Blizzard Portrait enclosures incorporate an adaptable projector mount to suit most projectors. The projector attaches to the mounting frame with screws provided.

Some tilt adjustment is available (max tilt angle depends on projector size)

Mounting hardware may differ between projectors, so we need to know the projector you're using when you order.

Specify left (shown here) or right projector slide, or fixed projector mount when ordering.

Not all lamp-based projectors may be used in portrait mode. Some may be used in portrait mode but only in one orientation — check with your projector manufacturer before ordering.

Tip: The thermal insulation option, shown here lines all available top, front, back and side surfaces with high-quality melamine foam with UL94 V-O (EN45545-2) fire ratings.

Ultra Short Throw



Blizzard UST outdoor enclosures allow you to paint a wall with video without having to own the block across the street!

UST enclosures are typically wider than standard landscape enclosures, to allow for the extreme width of the projection beam without clipping.

Blizzard UST enclosures may be configured to mount above the image (projecting down) or below it (projecting up).

Please note that, due to the differing characteristics of available UST optical systems, all UST enclosure orders are treated as custom or semi-custom. Tempest will collaborate with the projector manufacturer in each case to arrive at the optimal solution.

There are several different optical solutions competing for your ultra-short-throw business. Tempest works with all major projector manufacturers to create effective solutions that work for you. This one takes the innovative Epson periscopic lens.

Blizzard

Outdoor Projector Enclosures

All Blizzards come with four M10 threaded sockets — one at each corner — top and bottom. See the CAD drawings and 3D CAD blocks at Tempest.biz for precise dimensional data.

Stainless steel bolts are provided for attachment to any suitable support structure.

Tempest recommends only the use of stainless steel hardware for installing enclosures outdoors.

The following rigging options are available for most Blizzard enclosures:

Horizontal Pole or Truss Kit

Hang Blizzard safely on any truss or horizontal pipe with OD 50mm [2"]. The Truss kit allows you to:

- Tilt the enclosure by pivoting on the supplied truss clamps, +/- 30°
- Pan the enclosure up to 45° left or right
- Roll the enclosure +/- 5°

Angle Mounting Kit

Use this handy kit to mount any Blizzard enclosure at any angle between 15-55°. Using stainless steel low-profile Unistrut and all-stainless steel fittings, this kit can be used on the ground projecting up, or from above projecting down.

Stacking Kit

Stack two or more Blizzard enclosures of the same type using this stacking kit.

Male and female parts attach to the threaded corner holes, and are simply joined together using a stainless steel clevis pin.

See also Swivel Stacking Kit, next page)

Drop Arms

Use with a Stacking Kit to hang a lower Blizzard enclosure at an angle up to 60 degrees down.

Max Angles:

Blizzard 52.050	60°
Blizzard 52.100/125	51°
Blizzard 52.150	41°

Rigging Options



*Blizzard 52.150
Landscape with
52.XH.150L Horizontal
Pole/Truss Hanger Kit*



*This all-stainless steel angle
mounting kit lets you mount
any Blizzard enclosure at any
angle from 15-55°.*

*Use as shown here, projecting
up, or on the edge of a flat
roof, projecting down with
the enclosure reversed.*



*A pair of Blizzard 52.150
Landscape enclosures with
52.SK Stacking Kit. The kit
maintains the required 75mm
airflow gap between the two
enclosures*

*...just add the 52.DA Drop
Arms Kit to angle the
lower enclosure*



Blizzard Outdoor Projector Enclosures

Cyclovator

Set a projection angle up to 60° up or down. Perfect for rooftops when shooting down or at ground level when projecting up at a tall building. Stack up to two landscape Blizzards on each Cyclovator.

Requires Unistrut Kit 52.UR.xxx.

Unistrut Kit

Easy attachment to any structure using these two Unistrut rails. Simply use industry standard channel nuts to bolt to your structure, without worrying about precise hole locations.

Unistruts may be mounted bottom (shown here with Cyclovator) or top.

Swivel Stacking Kit

Stack two Blizzard enclosures (must be the same model), and angle them up to 40 degrees apart (20° either side of center) — great for short-throw edge blending jobs.

Stainless steel stacking kits attach to the M10 rigging points, and locking bolts are provided to secure pan angle when aligned.

Rigging Options

A pair of Blizzard 52.150 Landscape enclosures mounted on a Cyclovator.

Note that the bottom Blizzard requires a 52.UR.150 Unistrut kit to mount to the Cyclovator, and for angles more than about 35 degrees an Inlet Cowl (51.IC.15 here) keeps rain off the inlet filter.



52.SH.xxxx Sun Shade attaches easily to the Blizzard's top rigging points. Note that the xxxx matches the enclosure part number, eg 52.SH.100L for the Blizzard 52.100 landscape enclosures shown here.

Swivel Kits work with either Landscape or Portrait enclosures.

Feet Up Kit

Sometimes, you may need to flip the projector feet-up, to get more vertical shift on to an object below the enclosure.

The Blizzard Feet-Up Kit (52.FU) works in any Landscape Blizzard (fixed or slide projector mount), supporting the projector and raising it either 25, 50 or 75mm (1, 2 or 3 inches) to get the projection angle you need.

Be sure to include the height of the Feet-Up kit when choosing the correct Blizzard model for your project.



Blizzard

Outdoor Projector Enclosures

Sun Shade (52.SH.xxxx)

This aluminum panel mounts easily on the top of any Blizzard enclosure to provide extra daytime protection in hot, sunny climates. The cover not only deflects sunlight, but also provides a 75mm air gap between the shade and the enclosure top, promoting convective air movement. Recommended in conjunction with 52.TI thermal insulation in sunny areas with daytime temperatures frequently above 40°C [104°F].

Thermal Insulation Kit (52.TI.xxxx — factory fitted)

The thermal insulation kit adds 25mm of thermal insulation on the inside of the enclosure, conserving heat and reducing energy costs in cold climates, and moderating daytime temperatures in hot weather.

Positive Pressure and Salt Air (52.PP — factory fitted)

We do a lot of cruise ship jobs, as well as beach resorts and attractions where salt air can be a real problem. Now all Tempest G4 outdoor enclosures can be supplied with a Constant Positive Pressure setting that runs the enclosure fan(s) all the

Goldilocks™

How do we keep projectors from roasting when it's 50°C and there's no shade? And prevent condensation from destroying your projector overnight? Tempest's unique Goldilocks™ Operating System (patents pending) brings enclosure control to a new level.

Goldilocks keeps the air temperature inside your enclosure just right, removing heat from the projector when the lamp is on or when the enclosure is heated by the sun. We're changing the air every few seconds.

Goldilocks uses a heater to maintain a minimum temperature in cold climates.

time at low power, maintaining sufficient positive pressure to prevent salt or other pollutants entering the exhaust fan when the projector is not running.

Desert Filter Baffle (51.DFB.xx)

Wind-blown dust and sand can rip a filter apart in no time in a bad dust storm — so slow it down with this handy accessory.

The Desert Filter Baffle replaces the filter clamp under the enclosure body, and requires 100mm (4") clearance plus 75mm (3") airflow clearance below the enclosure.



*Sakuya Lumina,
Osaka, Japan.
Picture courtesy of
Moment Factory,
Montreal.*

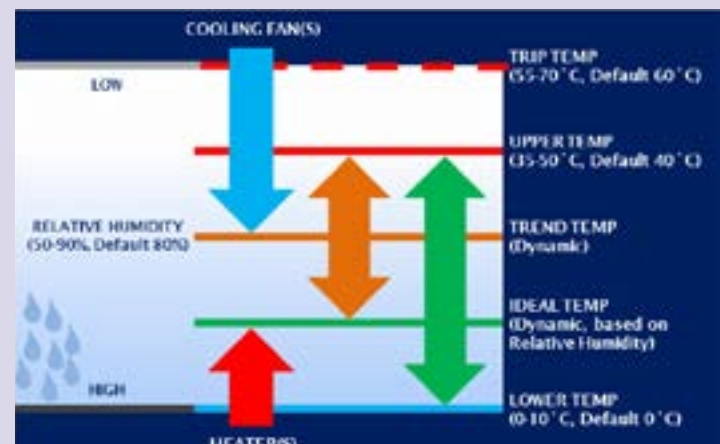

And Goldilocks tracks temperature and humidity 24/7, keeping relative humidity inside your enclosure just right by using

heaters to raise the air temperature when needed, adapting constantly to prevent deadly condensation.

Blizzard

Outdoor
Projector
Enclosures

What to do when it's HOT

Don't panic!

Blizzard enclosures have been in use for years in some very warm places — think Singapore, Dubai, Las Vegas. In many cases our standard enclosures will protect your equipment without problems.

Outdoor projection, by definition, is used at night. So you need to think about daytime and showtime temperatures quite separately:

Daytime — Insulation

In hot locations (anywhere with daytime temperature regularly exceeding 35°C), we strongly recommend specifying the Blizzard Thermal Insulation option (52.TI.xxx). This is a factory-fitted thermal insulation lining to the enclosure that effectively moderates daytime temperatures, reducing stress on your equipment and prolonging fan life.

Daytime — Hot Sun

If your enclosures will be regularly exposed to hot sun, the Blizzard Sun Shade (52.SH.xxx) is a simple, low-profile aluminum cover, that protects the enclosure from the midday sun and creates a 75mm (3in) air gap above the enclosure body. This protects the enclosure and its contents from the worst of the sun anywhere in the tropics or in desert conditions.

Showtime — Cooling

Blizzard enclosures generally deliver cooling air to the projector at 1-2°C (3-4°F) above the outside ambient temperature, when the projector is running. So if your projector is good for a couple of degrees above the likely ambient at show time, Blizzard is for you.

If the expected ambient is higher than your projector's comfort level (and see the sidebar to the right here), then you should take a look at our Oasis system, with integrated active cooling.

Tempest Oasis

Outdoor Projection Active Cooling Systems

In locations where show time ambient temperatures exceed your projectors' comfort level, you need to look at Oasis.

Oasis uses inverter heat pump technology to maintain a constant comfortable temperature for your projector, in any ambient between -15 and 50°C (5-122°F).

Oasis has another important benefit for RGB laser projectors: with a constant operating temperature, Oasis removes the risk of color shift as the laser light engines react differently to changes in temperature.

Find out more about Oasis by clicking on the link below:



Tip:

Read the Small Print

The conversion from lamps to laser light sources is now complete, we may never build another lamp-based enclosure, and that's generally a Good Thing.

But you need to study those laser projector specs very carefully — for example:

Environmental

The spec says 45°C (113°F) so we're good, right? Not necessarily. Read on and you may well find that light output is limited above, say, a 25°C (77°F) ambient. This might not be a big deal if it only happens a few nights of the year in your location, but if it's hot where you are, then it might...

Altitude

Most outdoor jobs are at or not far from sea level, but what if you're in the mountains? Check the effect of altitude on light output and environmental specs...

Doing your homework at the planning stage

can save a lot of time and trouble on the job site...

Blizzard with 51-52-series Outdoor Projection Enclosures with 51-52-series Outdoor Projection Enclosures and 51-52-series Outdoor Projection Enclosures are available for any standard or custom Blizzard enclosure.

Blizzard Outdoor Projector Enclosures

Tempest System Manager is a Windows app running on a local PC connected to your enclosures over a local area network.

TSM discovers any Tempest enclosures present on the network at initialization, and monitors system attributes in real time, including lamp, fan and heater status, temperature, relative humidity and more.

TSM may also be used to upload firmware updates to enclosure controllers over the network, without having to visit each enclosure.

The TSM license includes 12 months unlimited user support from Tempest electronics partner JESE, and continuing support is available for a modest annual fee.

Tempest System Manager

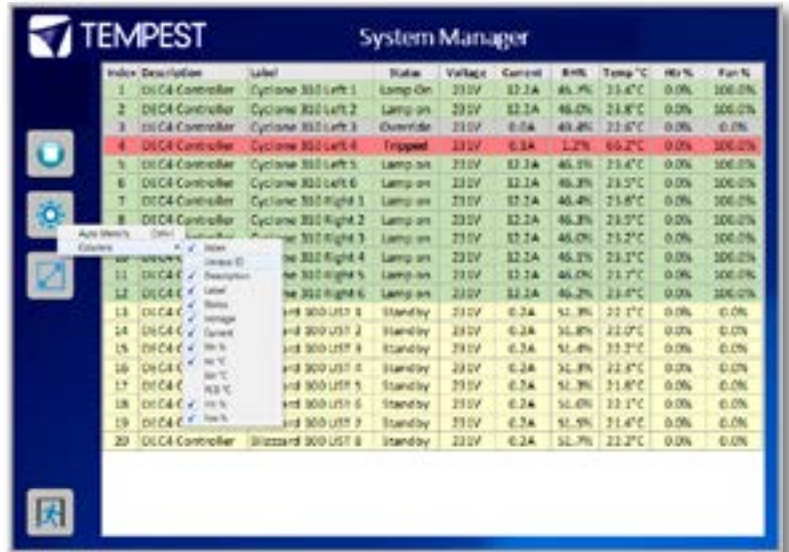

Monitoring Connections

There are two ways to connect enclosures to the TSM PC:

TSM Model Numbers

51.TSM.10	Up to 10 enclosures
51.TSM.25	Up to 25 enclosures
51.TSM.50	Over 25 enclosures

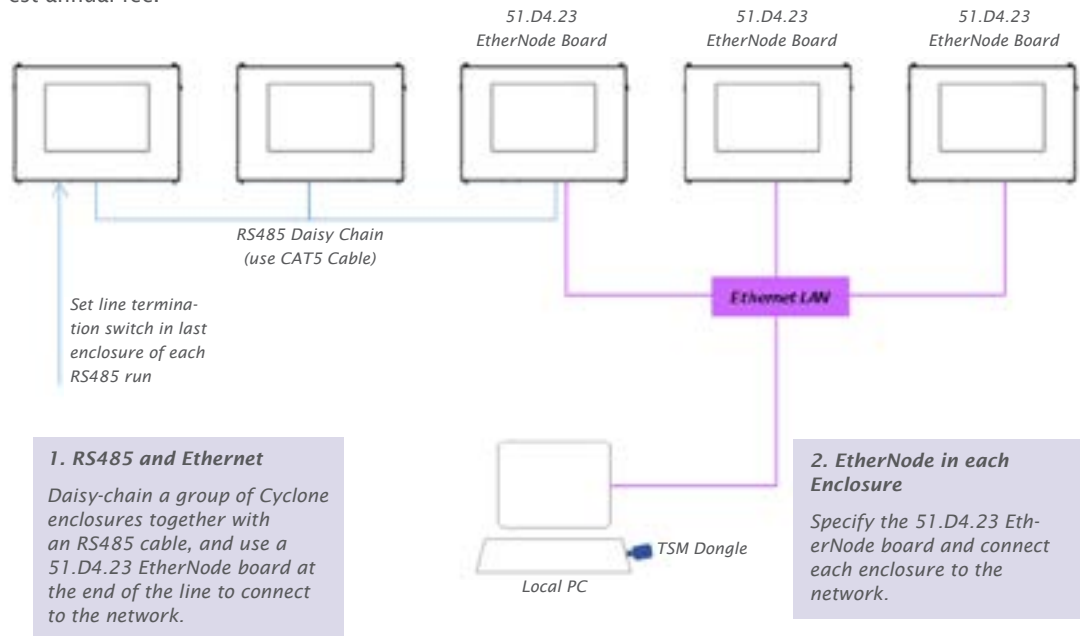

TEMP Protocol



Tempest also publishes a simple protocol for use by integrators wishing to monitor enclosures over an existing control network.

Connection options are the same as for System Manager, but the Ethernet board is 51.D4.15

Download the TEMP Developer Guide [here](#):

Blizzard Ordering Guide

Blizzard Projector Enclosure Dimensions ¹				Typical Projectors ³	Enclosure				Projector Maximum (Including Lens)										
Model	Orientation ²	Proj. Mount	Voltage		L (cm)	W (cm)	H (cm)	Kg	L (in)	W (in)	H (in)	Lb	L (cm)	W (cm)	H (cm)	L (in)	W (in)	H (in)	Watts
52.050.LF.IN	Landscape	Fixed	200-250VAC	Most, 5-7,000 Lumens	74	71	34	27	29	28	14	59	56	56	23	22	22	9	800
52.050.LS.IN	Landscape	Slide	200-250VAC																
52.050.LF.US	Landscape	Fixed	100-125VAC																
52.050.LS.US	Landscape	Slide	100-125VAC																
52.050.PF.IN	Portrait	Fixed	200-250VAC		74	43	69	29	29	17	27	64							
52.050.PS.IN	Portrait	Fixed	200-250VAC																
52.050.PF.US	Portrait	Fixed	100-125VAC																
52.050.PS.US	Portrait	Slide	100-125VAC																
52.100.LF.IN	Landscape	Fixed	200-250VAC	Most, 7-10,000 Lumens	86	76	37	39	34	30	15	85	69	61	25	27	24	10	1,250
52.100.LS.IN	Landscape	Slide	200-250VAC																
52.100.LF.US	Landscape	Fixed	100-125VAC																
52.100.LS.US	Landscape	Slide	100-125VAC																
52.100.PF.IN	Portrait	Fixed	200-250VAC		86	43	74	43	34	17	29	95							
52.100.PS.IN	Portrait	Fixed	200-250VAC																
52.100.PF.US	Portrait	Fixed	100-125VAC																
52.100.PS.US	Portrait	Slide	100-125VAC																
52.125.LF.IN	Landscape	Fixed	200-250VAC	Panasonic PT-MZ Series	86	86	37	43	34	34	15	94	69	74	25	27	29	10	1,250
52.125.LS.IN	Landscape	Slide	200-250VAC																
52.125.LF.US	Landscape	Fixed	100-125VAC																
52.125.LS.US	Landscape	Slide	100-125VAC																
52.125.PF.IN	Portrait	Fixed	200-250VAC		86	43	84	47	34	17	33	104							
52.125.PS.IN	Portrait	Fixed	200-250VAC																
52.125.PF.US	Portrait	Fixed	100-125VAC																
52.125.PS.US	Portrait	Slide	100-125VAC																
52.150.LF.IN	Landscape	Fixed	200-250VAC	Most 12-15,000 Lumens	107	76	42	48	42	30	17	106	89	61	30	35	24	12	1,800
52.150.LS.IN	Landscape	Slide	200-250VAC																
52.150.LF.US	Landscape	Fixed	100-125VAC																
52.150.LS.US	Landscape	Slide	100-125VAC																
52.150.PF.IN	Portrait	Fixed	200-250VAC		107	48	79	54	42	19	31	118							
52.150.PS.IN	Portrait	Fixed	200-250VAC																
52.150.PF.US	Portrait	Fixed	100-125VAC																
52.150.PS.US	Portrait	Slide	100-125VAC																

¹ Due to continuous product development, weights and dimensions are subject to change. Check with Tempest before construction work.

² Landscape and Portrait versions shown here. UST versions are custom or semi-custom. Please consult Tempest for details

³ For projectors not shown here, please contact Tempest — we will be happy to accommodate any projector type

All Blizzard products are built to order. Please contact Tempest for lead times.

All sales are subject to Tempest Lighting, Inc. Standard Terms and Conditions of Sale, available for download at www.tempest.biz.

All Schedule B Export Code: 9405.99.0000

Blizzard Enclosure Shipping Dimensions								
Model	L (cm)	W (cm)	H (cm)	Kg	L (in)	W (in)	H (in)	Lb
52.050.Lx.xx	91	91	61	43	36	36	24	94
52.050.Px.xx	91	91	61	45	36	36	24	99
52.100.Lx.xx	91	91	61	55	36	36	24	120
52.100.Px.xx	91	91	61	59	36	36	24	130
52.125.Lx.xx	91	107	61	59	36	42	24	129
52.125.Px.xx	91	107	61	63	36	42	24	139
52.150.Lx.xx	132	86	51	69	52	34	20	151
52.150.Px.xx	132	86	51	74	52	34	20	163



Options

Item #	For Model:	Description
52.TI.xxxx	Any Blizzard	Thermal Insulation Kit, recommended for hot or cold climates
52.PP	Any Blizzard	Blizzard Positive Pressure Option
51.D4.23	Any Blizzard	EtherNode Board (for Tempest System Manager)
51.TSM.xx	Any Blizzard	Tempest System Manager
0000.CL	Any Blizzard	Custom Color - specify black, white or any RAL #, plus desired gloss %

Accessories

Item #	For Model:	Description
52.UR.xxx	'xxx' = model #	Unistrut Mounting Rails (required with 55.C2)
55.C2	Blizzard 150	Tempest Cycloator Tilt Kit
52.XH.xxxL	'xxx' = model #	XYZ Hanger Kit for horizontal pole/Truss, Landscape Blizzard
52.XH.xxxP	'xxx' = model #	XYZ Hanger Kit for horizontal pole/Truss, Portrait Blizzard
52.AM.xxx	'xxx' = model #	Angle Mount Kit (same item # for landscape and portrait Blizzards)
52.SK	Any Blizzard	Blizzard Stacking Kit
52.DA	Any Blizzard	Blizzard Drop Arms Kit (requires Stacking Kit)
52.SH.xxxL	Landscape 050-150	Blizzard Sun Shade Kit, Landscape
52.SH.xxxP	Portrait 050-150	Blizzard Sun Shade Kit, Portrait
52.SS.xxxx	'xxxx' = model #	Blizzard Swivel Stacking Kit (Landscape or Portrait)
51.IC.08	Portrait 050-125	Inlet Cowl (Order 2 per enclosure)
51.IC.16	Portrait 150	Inlet Cowl (Order 1 per enclosure)
51.IC.11	Landscape 050-125	Inlet Cowl (Order 1 per enclosure)
51.IC.15	Landscape 150	Inlet Cowl (Order 1 per enclosure)
51.DFB.08	Portrait 050-125	Desert Filter Baffle (Order 2 per enclosure)
51.DFB.16	Portrait 150	Desert Filter Baffle (Order 1 per enclosure)
51.DFB.11	Landscape 050-125	Desert Filter Baffle (Order 1 per enclosure)
51.DFB.15	Landscape 150	Desert Filter Baffle (Order 1 per enclosure)
51.HF.08	Portrait 050-125	Replacement Salt Fog Inlet Filter (Order 2 per enclosure)
51.HF.23	Portrait 150	Replacement Salt Fog Inlet Filter (Order 1 per enclosure)
51.HF.11	Landscape 050, 100	Replacement Salt Fog Inlet Filter (Order 1 per enclosure)
51.HF.15	Landscape 150	Replacement Salt Fog Inlet Filter (Order 1 per enclosure)

Custom Colors

All the enclosures in this brochure are shown in our popular standard light bronze finish.



White, Black or any RAL color are available to order.



Blizzard Configurator

Please complete one sheet for each Blizzard type required and email to us at info@tempest.biz

Name *			
Company *			
Email *			
Phone			
Project Name & Location *			
Projector & Lens Make/Model #	Projector: *	Lens: *	
Blizzard Model *	52.	Quantity	
Destination Country *			
Expected Install Date *			
Enclosure Type *	Landscape	Portrait	UST
Projector Mount *			
Projector Orientation *	Landscape/UST: Feet Down		Feet Up
	Portrait: Feet Left		Feet Right
Options			
Thermal Insulation	Qty	No	
Inlet Cowl	Qty	No	
Desert Filter Baffle	Qty	No	
Positive Pressure	Qty	No	
Sun Shade	Qty	No	
Cyclovator	Qty	No	
Angle Mount Kit	Qty	No	
Stacking Kit	Qty	No	
Swivel Stacking Kit	Qty	No	
Unistrut Kit	Qty	Mounting	No
Ethernet Comms	Qty	Type	No
XYZ Kit (horizontal)	Qty	No	
Feet up Kit	Qty	No	
Drop Arms Kit	Qty	No	
Spare Inlet Filter	Qty	No	

Color, standard	Light Bronze	Black	White
Color, custom <i>Gloss levels higher than 30% may show up weld marks. Tempest accepts no responsibility in this event.</i>	Custom, RAL #		
	Gloss Level	%	
	Salt Fog Primer:	Yes	No

UST Lens Configuration:

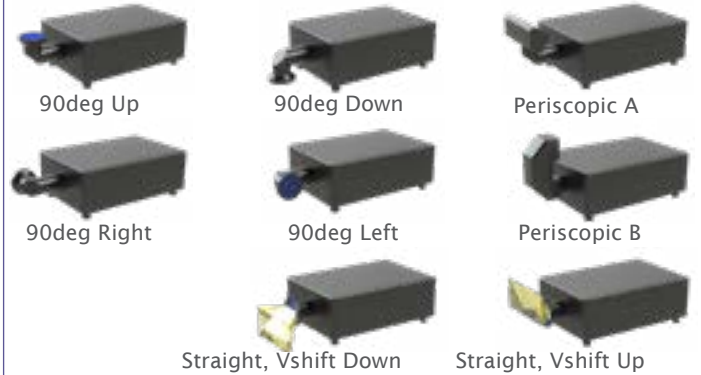

Custom Requests:

Factory Use Only:	SO #:	Date:	
Electrical:	IEC	NEMA	Wiring p:
Test:	Function	Projector	
Hardware Kit:			

* Left Projector Slide shown here (doors open both sides)

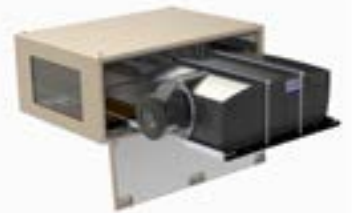

 Made in the USA

©Tempest Lighting, Inc., December 2023

In the interest of continuous product improvement, specifications are subject to change without notice

Tempest Lighting, Inc.,

11845 Wicks Street, Sun Valley, CA 91352, USA

www.tempest.biz info@tempest.biz

t: +1 818 787 8984 f: +1 818 252 7101