



User Manual

Zen

Revision 8.4

November, 2020

© Tempest Lighting, Inc.



Table of Contents

Table of Contents.....	2
Approvals – Europe	5
Approvals – China	6
Introduction	7
IMPORTANT: Safety Advisories	7
Installation.....	8
Dimensions, Weights & Rigging Points.....	9
Mounting Hardware Options	10
Mounting Bolts	10
Unistrut Kit.....	10
Access Clearance	11
Enclosure Tilt	11
Wiring the Enclosure	12
Power Wiring	12
SAFETY NOTICE	12
Electrical Standards.....	12
Wiring Access.....	13
Using the Conduit Knockouts.....	13
Wiring Access.....	13
One or Two Power Circuits?	15
Single Feed Power Termination.....	16
Split Feed Power Termination	16
North America 208V, Japan 200V Single Feed.....	17
North America 208V, Japan 200V Split Feed	17
International, 230V Single Feed.....	18
International, 230V Split Feed	18
Remote Monitoring Connections	19
RS485 (DMX/RDM) Cable Terminations.....	20
Line Termination Switch Settings	21
Projector Power Control using DMX512	22
DMX/RDM Network, using JESE RDM-TRI.....	23
Digital Enclosure Control.....	24
Schematic.....	24
DEC4 Main Functions	25
Firmware Revision	25
Factory Settings – Data Modes	25

Hardware Indicators & Fuses	26
DEC System Control Board	26
PWM Fan Transition board (up to 5 fans)	27
Operating Modes	28
RDM Only Monitor (Factory Default)	28
RDM+DMX Control	28
RDM+DMX Service	28
DEC4 Control Parameters – PWM Fan Control	29
General Description	29
Optimizing PWM Control Settings	30
Control Interface	31
User Interface LCD Display	32
Control Interface Operation	32
Control Menu	33
Set Data Options	33
Set Temp Units	34
Set Temp Ranges	34
Set Max Humidity	34
Set Lamp On Point	35
Reset Lamp Hours	35
Set Fan Function	35
Status Display	37
DEC4 Firmware Updates	38
Indirect Firmware Updates (System Control Board and RS485 Board)	42
Requirements	42
Installation Procedure	42
End.	46
Mounting the Projector	47
Zen 050-150 Projector Mounting	47
Projector Mounting Zen 210 and Up - Landscape	48
Projector Mounting Zen 210 and Up – Landscape, Feet-up	49
Projector-specific Mounting	50
Christie D4K-40 RGB - Landscape	50
Christie D4K-40 RGB – Portrait	51
DPI Insight 4K	52
UST Projector Mounts	52
Important: Locating the Temperature Sensor	53
Important: Check Lamp-on Current	54

Important: Check Fan Setup and Temperature Range Settings	54
Connect Projector and Aux Equipment.....	54
Projector Connector Types.....	55
User Interface Mount.....	56
Routine Maintenance.....	57
Clean Port Glass.....	57
Check Filter.....	57
Check Temperature/Humidity Sensor.....	57
For After Sales Support.....	57
Troubleshooting.....	58
Warranty.....	59
Appendix – TEMP Protocol.....	60
Physical Layer.....	60
Developer’s Guide.....	60

Approvals – Europe



CERTIFICATE AND DECLARATION OF CONFORMITY
FOR CE MARKING

Tempest Lighting, Inc.

11845 Wicks Street, Sun Valley, CA 91352, USA

t: +1 818 787 8984 f: +1 818 252 7101 e: info@tempest.biz

www.tempest.biz

Tempest Lighting, Inc. declares that their
Zen Projector Enclosure Series 57.xxx.xx

complies with the Essential Requirements of the following EU Directives:

Low Voltage Directive 2014/35/EU Test Report 60065-6500-01-14

Electromagnetic Compatibility Directive 2014/30/EU Test Report 61000-6500-03-14

and further conforms with the following EU Harmonized Standards:

EN 60065 : 2014/AC:2016 Test Report 60065-6500-01-16

EN 60529:1991/AC:2016-12 Test Report 60529-6500-02-16

EN 61000-6-3:2007+A1:2011 Test Report 61000-6500-03-14

EN61000-6-1:2007 Test Report 61000-6500-03-14

EN55015:2019/A11:2020 Test Report 61000-6500-03-14

Dated: 21st September 2020

Position of signatory: President

Name of Signatory: Tim Burnham

Signed below:

on behalf of Tempest Lighting, Inc.

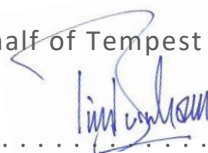

Approvals – China



强制性认证目录外产品确认书
Confirmation Letter for Products
Outside the Scope of China Compulsory Certificate

Ref. No: CL-TEMPEST-160818-1

申请人: Applicant: Tempest Lighting Inc.		地址: Address: 11845 Wicks St., Los Angeles, CA 91352 United States
生产厂名称: Factory: Tempest Lighting, Inc.		地址: Address: 11845 Wicks St., Los Angeles, CA 91352, USA
产品名称: Product Name: 投影仪外壳, 灯具外壳 Projector Enclosures Moving Light Enclosures Lighting Enclosures	型号: Model: 18xx.IN, 19xx.IN, 2xxx.IN, 66xx.IN, 52.xxx.IN, 53.xxx.IN, 54.xxx.IN, 55.xxx.IN, 56.xxx.IN	商标: Trademark: Tornado, Twister, Thunder, Blizzard, Whispr, Typhoon, Cyclone, Tacit
产品标准: Standard: /		HS code: 9405.99.0000
产品描述(包括使用场所) Product Description (utilization of product) : Enclosures for high-powered luminaires and video projectors for outdoor use and indoor noise attenuation. For professional use only. 产品为用于户外和室内噪声衰减大功率灯具和视频投影仪的外壳。仅供专业使用。		
确认意见 Conclusion: According to the product description, the models above are out of CCC scope 基于产品描述, 如上型号的产品在中国强制性产品目录之外。 本确认书的有效有效期至: August 18th, 2017 Validity Period		



Introduction

Thank you for purchasing a Tempest enclosure! We have worked hard to provide you with the very best product available for its purpose, and we shall continue to do everything possible to ensure that it works well for you for many years to come.

Please read this manual before starting work!

In the event of difficulty, please contact your Tempest reseller or Tempest direct:

info@tempest.biz

+1 818 787 8984

We will do everything we can to help you get the very best results from your Tempest enclosure.

IMPORTANT: Safety Advisories

- All installation and rigging work done must where applicable be designed and built in accordance with norms and standards of the local authority having jurisdiction of the installation site. It is the responsibility of the installer to obtain such approvals as may be required to achieve full compliance.
- All electrical work must be carried out by a suitably licensed electrical contractor in full compliance with local electrical standards.
- Lifting: some enclosures and the equipment inside them may be heavy. Use properly rated lifting equipment where appropriate and never attempt to carry out work with fewer than the number of workers needed to lift safely.
- It is the responsibility of the installer to ensure that all local building, safety and electrical codes are strictly adhered to in the installation of this enclosure. Tempest Lighting, Inc., its employees and agents are in no way responsible for damage arising from failure to follow either the instructions in this manual or building, safety and electrical codes prevailing at the installation location.
- Do not attempt to install or operate the enclosure before fully reading and understanding this manual
- Never allow anyone who has not read this manual to open the enclosure or perform maintenance on the projector within.
- Never leave the enclosure unattended when open.
- Always make sure all bolts and latches are tight and safety locks are in place after performing any form of maintenance on the unit.
- Do not open any electrical boxes until power has been shut off to all supply lines to the enclosure (including the one powering the projector).
- Do not open the enclosure in wet weather.

Installation

Integral Cooling

Everything is in the box – air is drawn in through an acoustic foam labyrinth in the enclosure base, and exhausted out of the front of the enclosure, driven by an array of variable-speed dc fans, muffled by a further acoustic foam exhaust labyrinth above the projector chamber. Typical sound pressure attenuation approximately 25dBA*.

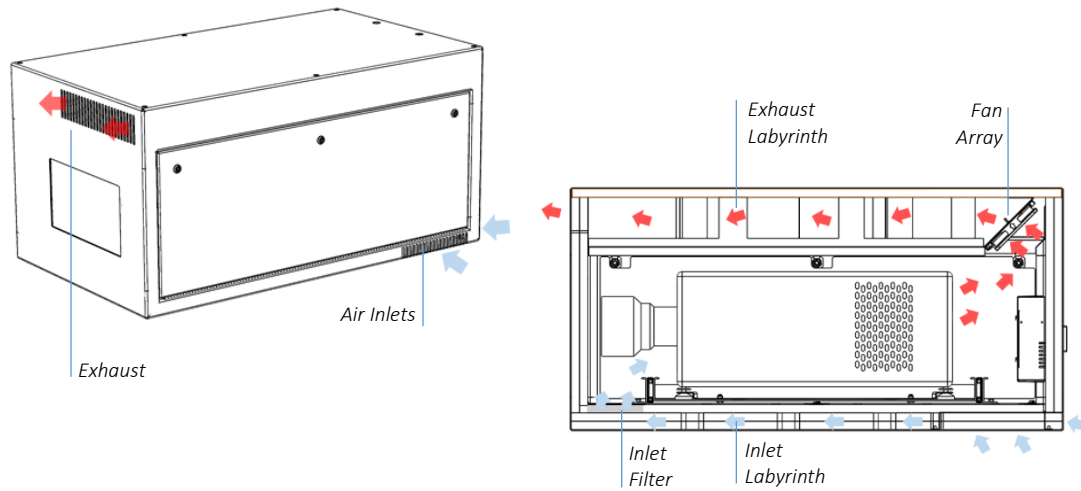

DO NOT OBSTRUCT THE AIR INLET AND EXHAUST VENTS.

** actual sound pressure attenuation values may vary, depending on the room acoustics and projector sound frequency profile.*

Dimensions, Weights & Rigging Points

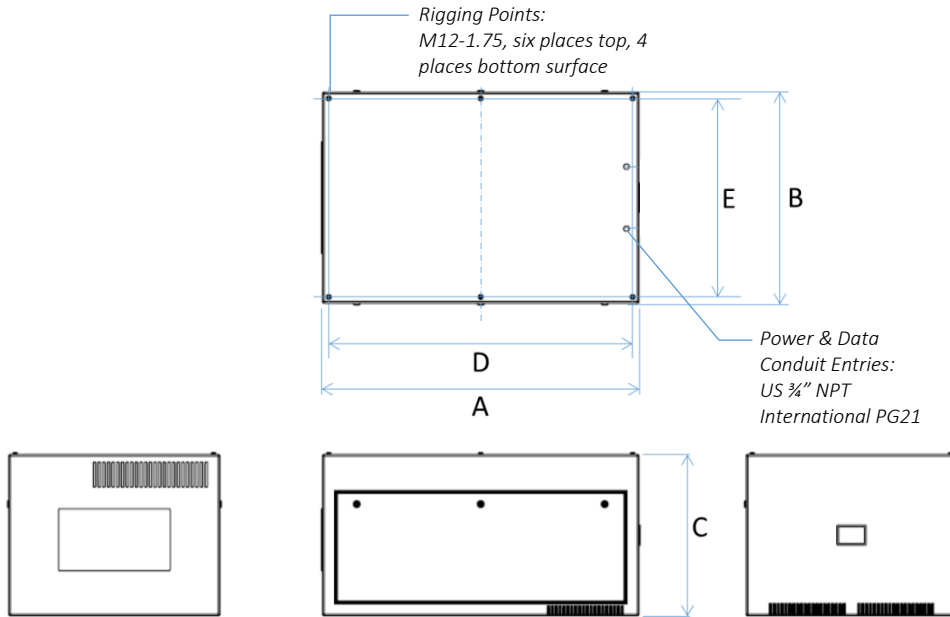

Download Detailed PDF and DWG 2D drawings, and 3D CAD Blocks at www.tempest.biz

Zen	A in	A mm	B in	B mm	C in	Cmm	D in	D mm	E in	E mm	W lb	W kg
57.050L	30	762	30	762	23	584	28	711	28	711	104	47
57.100L	34	864	30	762	23	584	32	813	28	711	118	54
57.150L	44	1,118	32	813	26	660	42	1,067	30	762	184	84
57.210L	51	1,295	32	813	26	660	49	1,245	30	762	214	97
57.310L	59	1,499	34	864	29	737	57	1,448	32	813	293	133
57.320L	67	1,702	37	940	29	737	65	1,651	35	889	362	165
57.324L	58	1,473	37	940	38	965	56	1,422	35	889	411	187
57.324P	58	1,473	30	762	45	1,143	56	1,422	28	711	394	179

Projector Maximum Dimensions/Power (models 57.050-150)							
Zen	L in	L mm	W in	W mm	H in	H mm	Watts
57.050L	22	22.5	9	559	572	229	800
57.100L	27	24.5	10	686	622	254	1,250
57.150L	35	24.5	12	889	622	305	1,800

Mounting Hardware Options

Mounting Bolts

- **HANGING:** Each Enclosure **MUST** be mounted with all six rigging points.
- **STANDING:** Each Enclosure must be mounted with all four rigging points.
- All mountings must be made using the M12 threaded holes on the of the enclosure.
- Use an 8mm hex key to secure the M12 socket cap screws provided.

IMPORTANT SAFETY NOTICE

Installer must ensure that all mounting points are secure and conform to local safety regulations. Tempest Lighting Inc. accepts no responsibility for damage or injury arising from inappropriate or unsafe installation.

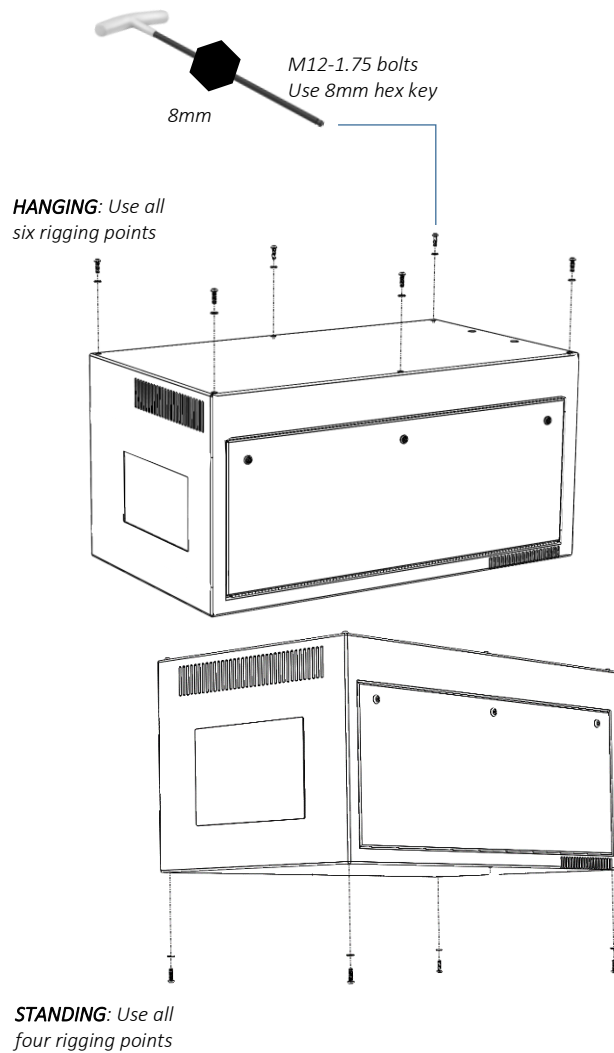

Unistrut Kit

If mounting positions for the corner bolts are not convenient, use the Unistrut Kit (55.UR.xxx) to add two Unistrut rails and Unistrut spring nuts to the top or bottom of the enclosure.

Using standard Unistrut channel nuts, the enclosure may now be attached at any point along the Unistrut rails.

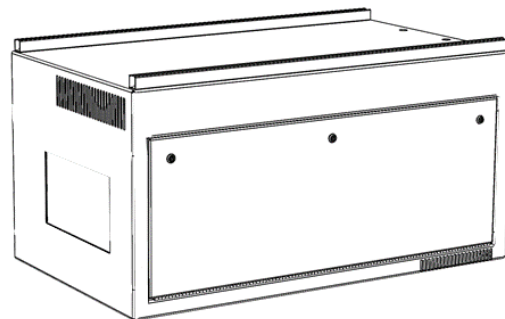

Access Clearance

You may specify the projector slide to extend to the left (shown here) or right side.

Allow at least as much clearance as the enclosure width on the opening side.

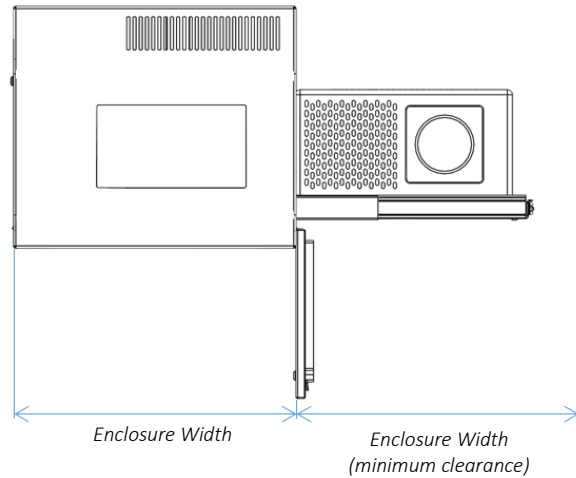

Enclosure Tilt

Enclosure may be tilted up to 10° up or down.



Enclosure must NOT be tilted to left or right. This may lead to equipment damage and personal injury.



Note: These limitations may not apply to custom enclosures designed for specific applications. If in doubt, consult factory.

Wiring the Enclosure

Power Wiring

SAFETY NOTICE

All power wiring must be performed by a competent electrician, appropriately licensed in the jurisdiction where the installation takes place. All electrical work must be done in full compliance with all electrical and safety norms applicable to the installation site. Isolate all power feeds before opening the enclosure.











Tempest Lighting, Inc., its employees and agents will not be held responsible for damage or injury caused by disregarding this notice.

Electrical Standards

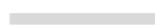
Important:

Zen enclosures run on any electrical supply, from 100-250VAC, 50/60Hz.

North America and Japan: 200-208VAC using two hots and no neutral is acceptable

	L
	N 220-250VAC
	E
	L
	N 100-125VAC
	E
	L1
	L2 200-208VAC
	E
	N (for 120V Aux Power if required)

Power feed Rating:

EITHER Single Feed:

Single circuit, power rating to suit projector plus 150W

OR Split Feed (see next section):

One circuit, power rating to suit projector, AND

One circuit, power rating 150W for enclosure

Note:

- (1) Fans are 48Vdc
- (2) Fan Power Supply is autoranging between 100-240VAC, 50/60Hz
- (3) Electronics are autoranging for any voltage 90-265VAC, 50/60Hz

Wiring Access

You have a choice of conduit entry points: either on the top or the back panel.

Conduit openings accept PG21 (International, 29mm hole) and 3/4" NPT (North America) conduit fittings.

Use permanent or flexible conduit to connect power and signal cables to your enclosure.

ALWAYS RUN POWER AND SIGNAL CABLES IN SEPARATE CONDUITS.

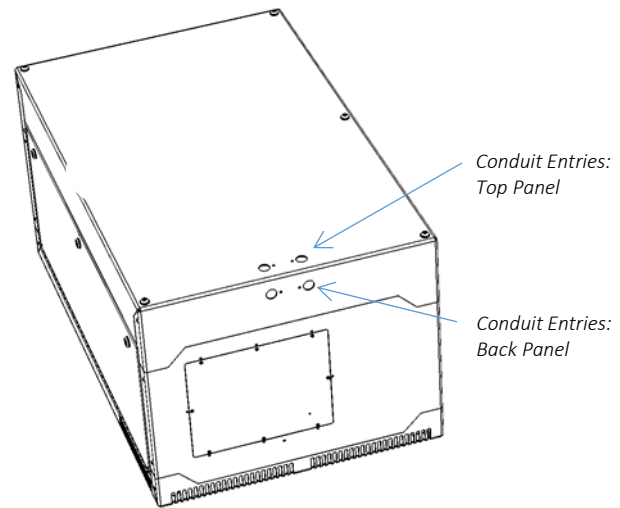

Using the Conduit Knockouts

Use a screwdriver to bend the inner conduit blank covers back inside the enclosure. It is not necessary to break off the cover tabs – just bend them right back.

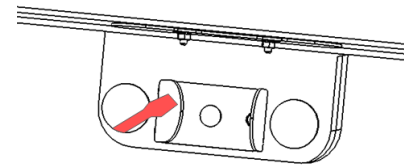

Inside view

Wiring Access

Remove the wiring cover screws and washers and remove the wiring compartment cover.

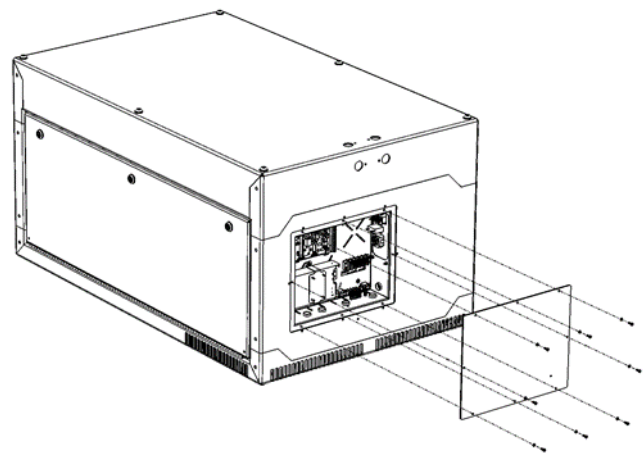

Identify the following parts:

- DC Fan Control Daughter Board
- Ethernet Daughter Board
- RS485 Comms Daughter Board
- DEC4 Motherboard
- AC Terminals
- Fan Power Supply Unit
- Ground/Earth Terminals

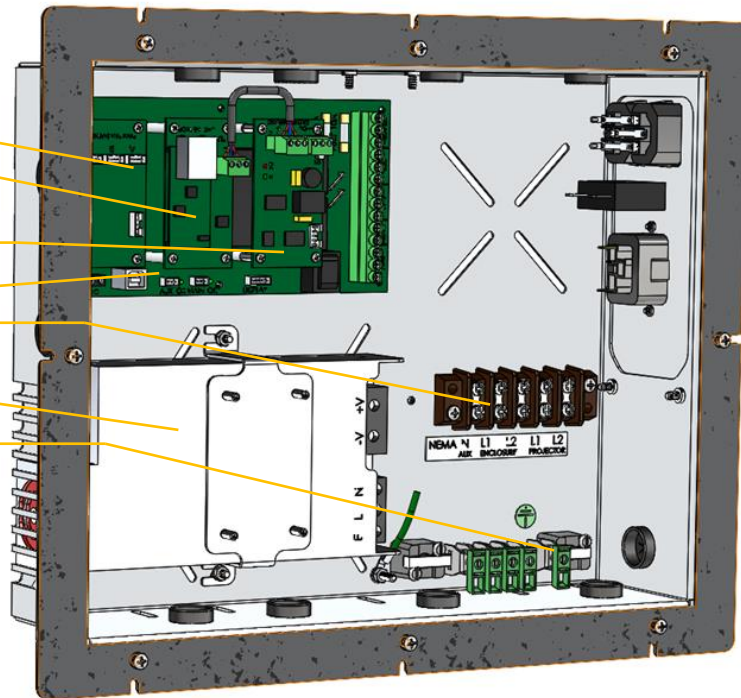

For clarity, internal wiring is not shown

- Duplex IEC C13 Outlet (Aux Power)
- Aux Power Circuit Breaker (10A)
- Projector Power Receptacle (types differ)

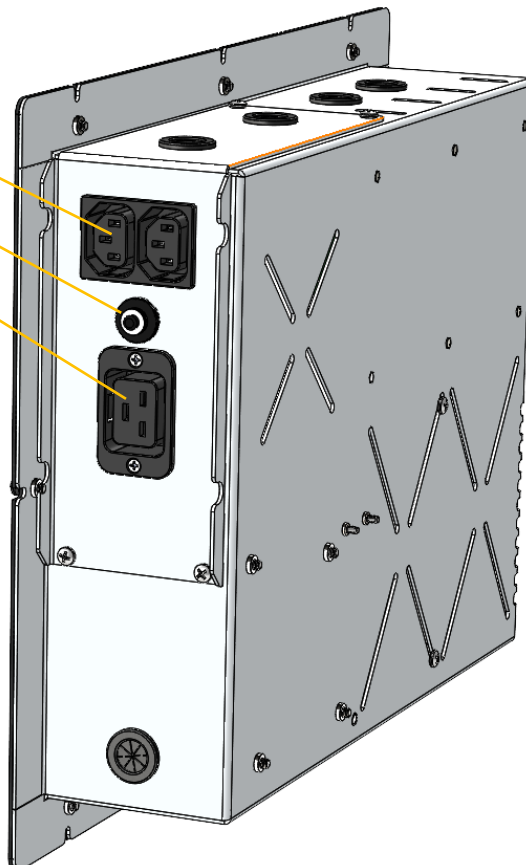

One or Two Power Circuits?

Tempest enclosures may be wired on single or double circuit supplies. On a single feed, both enclosure and projector are permanently on. With a split (double) feed supply, you can switch off the projector when not in use, while the enclosure continues to protect it 24/7.

Tip: most people use single feed.

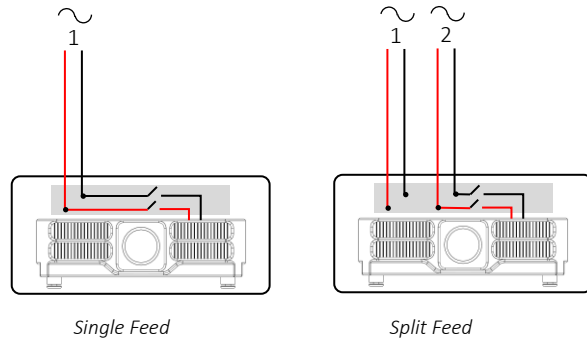

Single Feed

- Enclosure and projector are permanently on.
- Enclosure and Projector must be rated for the same voltage.
- Supply must be rated for projector current plus 500 watts.
- Supply must be permanently ON.

Split feed

- Enclosure power (FEED) must be permanently ON.
- Projector power (SPLIT) may be switched off.
- Enclosure power must be rated for 500 watts.
- Projector power must be rated for the projector (see projector manual).

Projector and enclosure power must be same voltage.

For **single feed** wiring, **no modification** to the DEC4 Controller motherboard is needed.

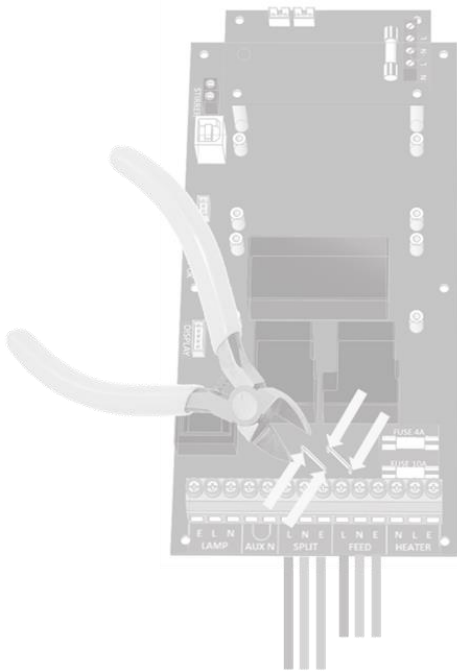

IMPORTANT:

For **split feed** wiring, use a side cutter to cut both AC links at both ends:

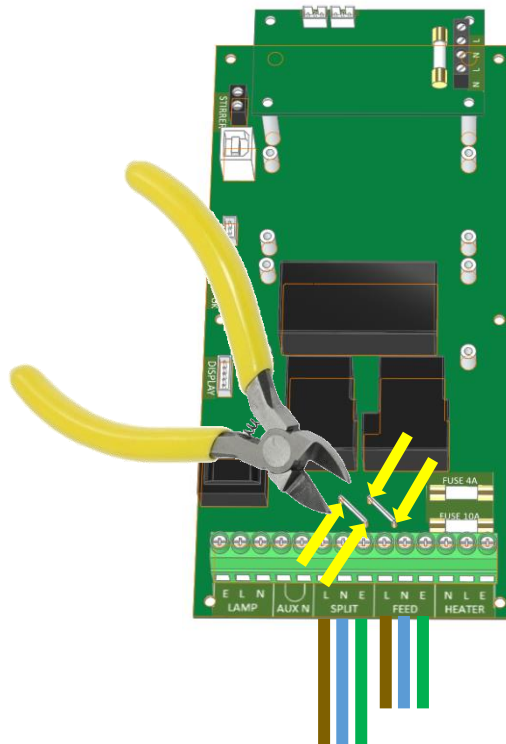

Single Feed Power Termination

- Connect Earth/Ground wire to Ground Terminal
- Connect Live and Neutral to the terminals marked L and N ENCLOSURE

IMPORTANT: Use only copper wire, rated to comply with local electrical codes. Terminal Screw Torque Setting 0.5Nm/4.5in lb.

SEE DIAGRAMS ON FOLLOWING PAGES

Split Feed Power Termination

- **STOP!** Did you cut the power links? See above.
- Connect Earth/Ground wire to Ground Terminal
- Connect Enclosure feed to the terminals marked **ENCLOSURE**
- Connect Projector feed to the terminals marked **PROJECTOR**
- Open the Split Feed Wiring Kit – it contains two short cables to link the **PROJECTOR** supply terminals to the **DEC SPLIT** terminals:

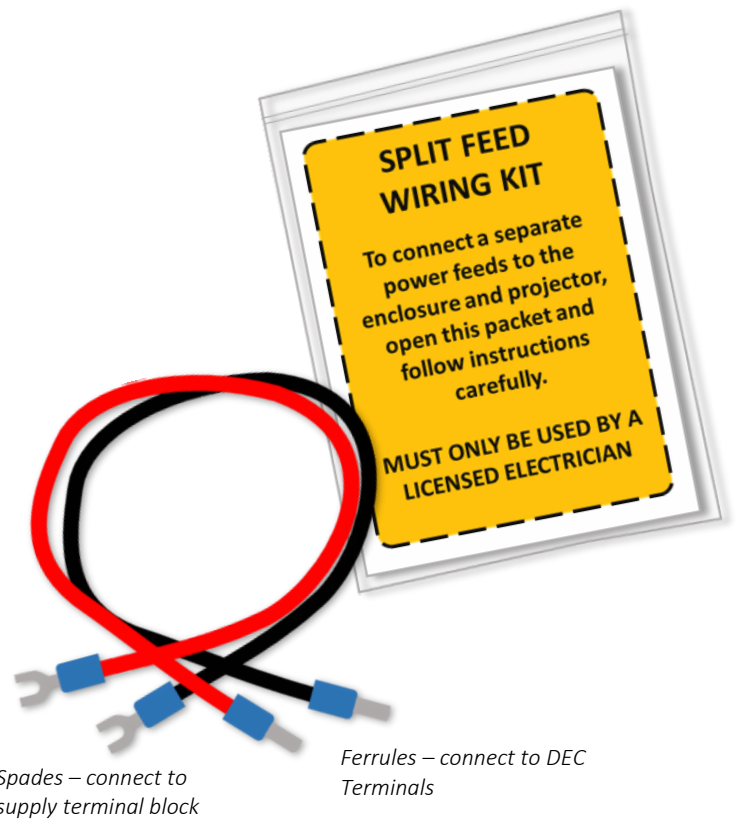

- Connect Split feed wires provided between L and N PROJECTOR and motherboard L and N SPLIT terminals

IMPORTANT: Use only copper wire, rated to comply with local electrical codes. Terminal Screw Torque Setting 0.5Nm/4.5in lb.

SEE DIAGRAMS ON FOLLOWING PAGES

North America 208V, Japan 200V Single Feed

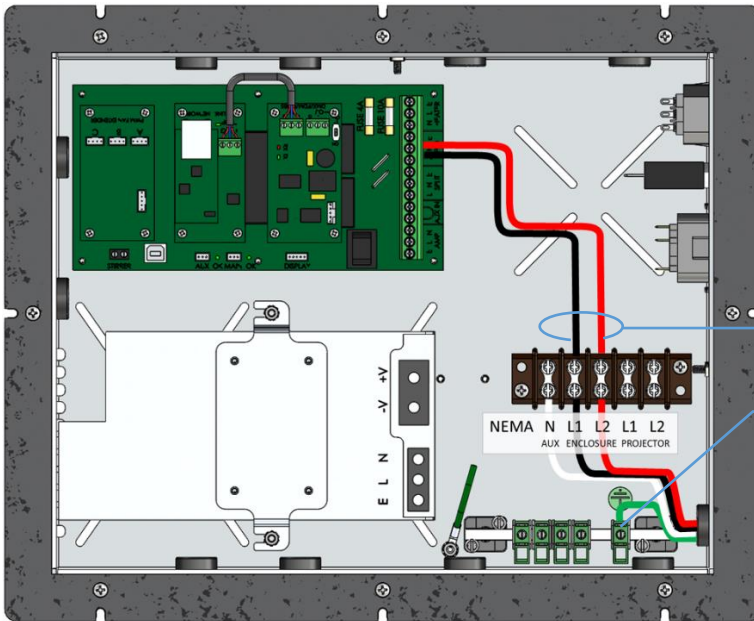

Single Feed

200-208VAC Single-Phase (2 hots)

Protective Earth (ground)

10A Neutral for 120V Aux power

Fuse/Circuit breaker rating: Projector power plus 500W (Max 30A)

Factory Installed feeds

Supply Ground Terminal

User-installed Supply wiring

IMPORTANT: Use only copper wire, rated to comply with local electrical codes. Terminal Screw Torque Setting 0.5Nm/4.5in lb.

(for clarity, internal wiring not shown)

North America 208V, Japan 200V Split Feed

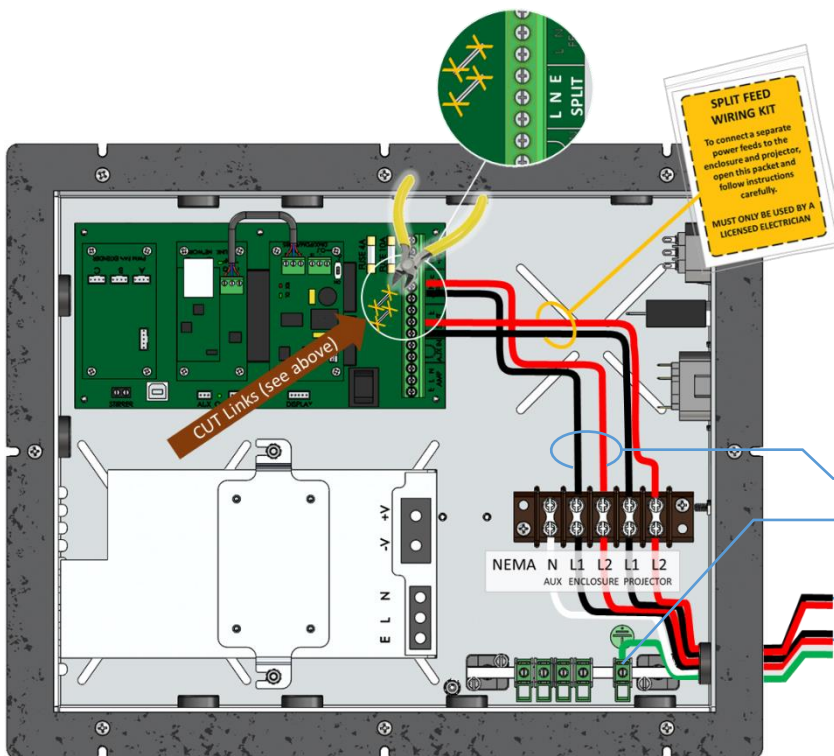

Split Feed

Enclosure: 10A 200-208VAC Single-Phase (2 hots)

10A Neutral for 120V Aux power

Protective Earth (ground)

Projector: 200-208VAC Single-Phase (2 hots)

Fuse/Circuit breaker: Projector power rating (Max 30A)

Factory Installed feeds

Supply Ground Terminal

User-installed Supply wiring:

Projector

Enclosure

IMPORTANT: Use only copper wire, rated to comply with local electrical codes. Terminal Screw Torque Setting 0.5Nm/4.5in lb.

(for clarity, internal wiring not shown)

International, 230V Single Feed

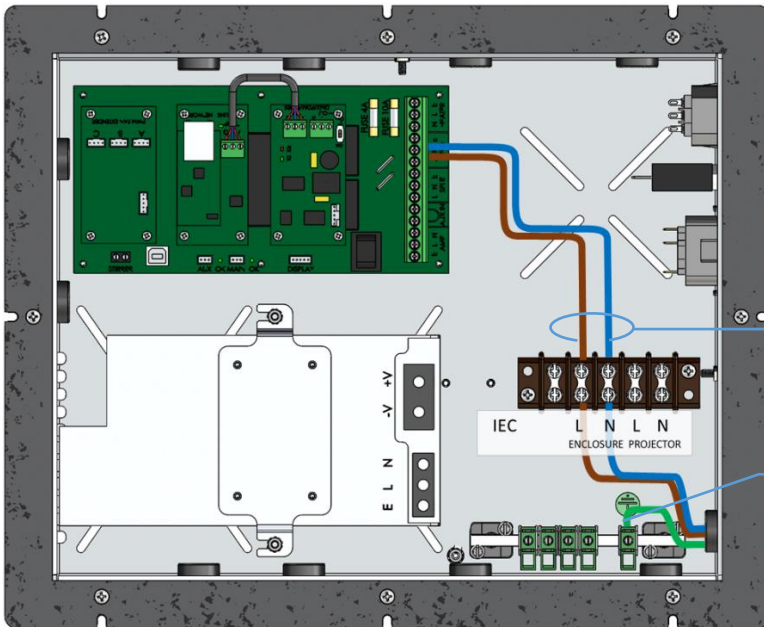

Single Feed

230VAC Single-Phase (L + N)

Protective Earth (ground)

Fuse/Circuit breaker rating: Projector power plus 500W (Max 30A)

Factory Installed feeds

Supply Ground Terminal

User-installed Supply wiring

IMPORTANT: Use only copper wire, rated to comply with local electrical codes.

Terminal Screw Torque Setting
0.5Nm/4.5in lb.

International, 230V Split Feed

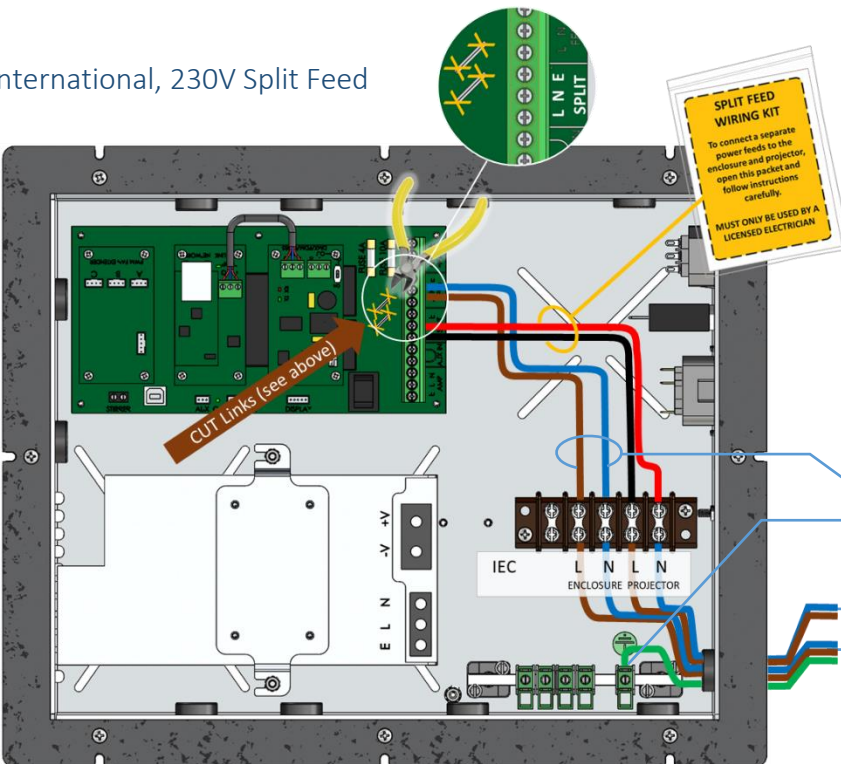

Split Feed

Enclosure: 10A 230VAC Single-Phase (L + N)

Protective Earth (ground)

Projector: 230VAC Single-Phase (L + N)

Fuse/Circuit breaker: Projector power rating (Max 30A)

Factory Installed feeds

Supply Ground Terminal

User-installed Supply wiring:

Projector

Enclosure

IMPORTANT: Use only copper wire, rated to comply with local electrical codes. Terminal Screw Torque Setting 0.5Nm/4.5in lb.

(for clarity, internal wiring not shown)

Remote Monitoring Connections

Tempest G4 enclosures optionally support three types of remote monitoring:

1. Direct via Ethernet, using Tempest TEMP protocol (see Appendix – TEMP Protocol)
Requires 51.EN Ethernet board
2. Grouped via RS485, using an Ethernet bridge and Tempest TEMP protocol (see Appendix – TEMP Protocol)
3. Grouped via RS485, using DMX/RDM – see next page
Requires one 51.485 RS485 board per enclosure
Requires one 51.485 RS485 board per enclosure and one 51.EN Ethernet board per bridge

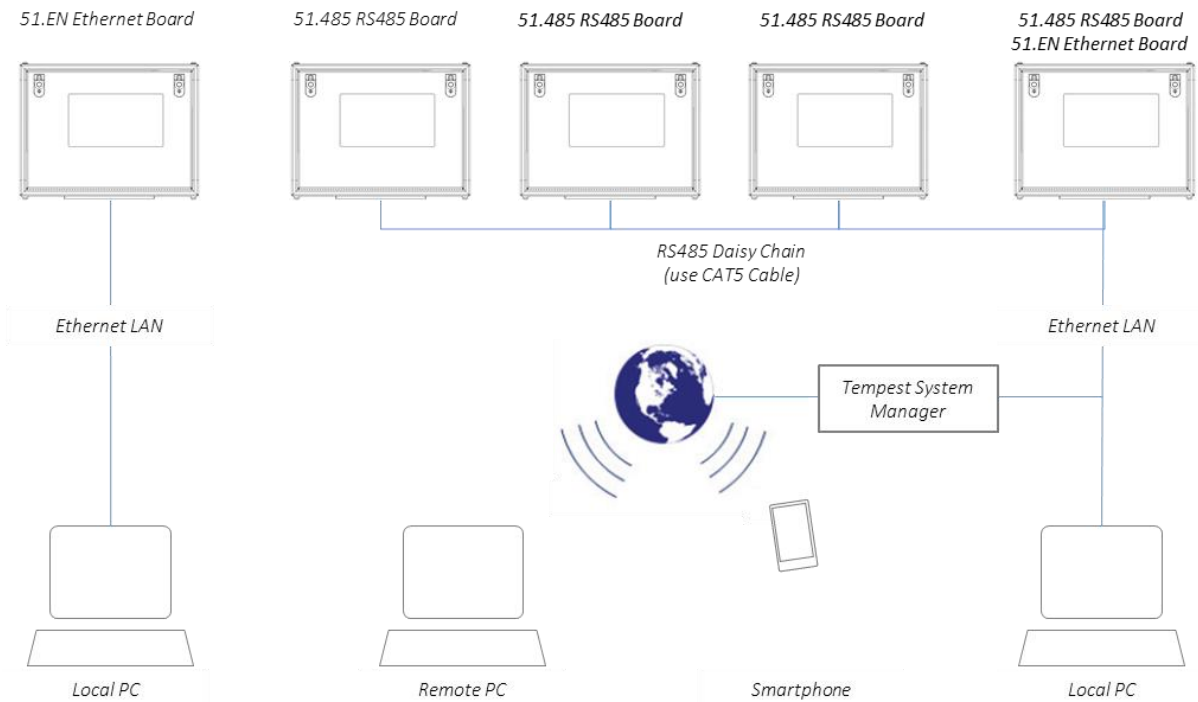

Note: Consult factory for Tempest System Manager and web-based monitoring availability

RS485 (DMX/RDM) Cable Terminations

DECA System Control Board, with three typical Daughter Boards:

1. AC Fan Controller
2. Ethernet Bridge
3. RS485 Comms

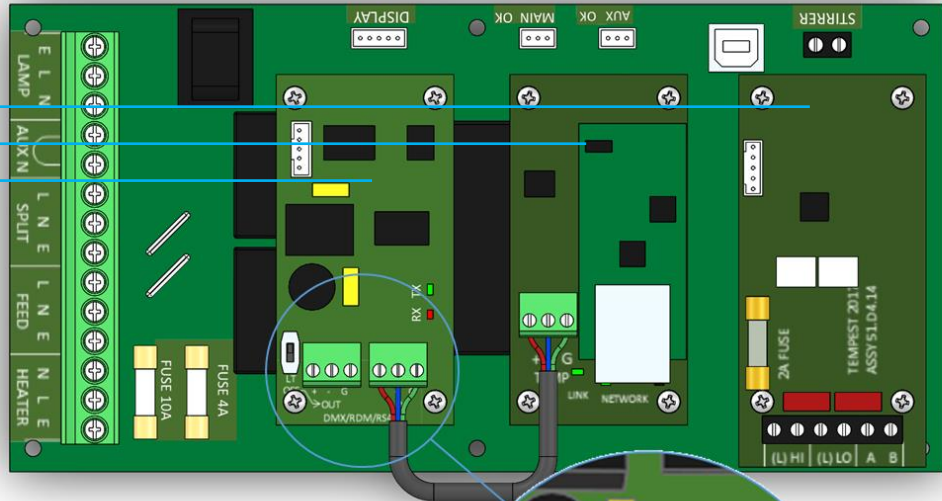

Loop a shielded twisted pair cable (eg Belden 9841, though many people now use a CAT5e cable) from the control/monitoring point, around all enclosures.

Maximum total cable length is 1,200M (4,000ft). For longer runs and wildly distributed systems, use a DMX/RDM splitter (make sure that it supports RDM) and multiple cable runs.

Use the termination switch to terminate each RS485 cable run at the last enclosure on each run.

RS485 Line Termination (LT) Switch:

TERMINATED

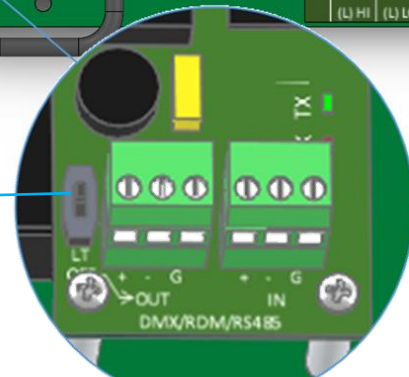

Data + Data - Common Data + Data - Common

DATA OUT

DATA IN

Terminal Screw Torque Setting 0.5Nm/4.5in-lb



Tempest recommends the JESE SH8 DMX/RDM Splitter for large or complex RS485 networks.

JESE RDM-TRI interface connects to a PC via USB to monitor and control a network of Tempest enclosures.
Tempest Item # 2000.195



Line Termination Switch Settings

1. DMX/RDM control over RS485:

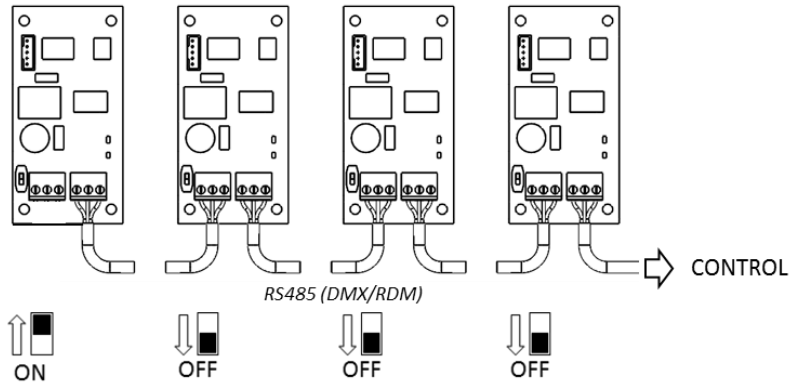

2. TEMP Control of an enclosure group via Ethernet

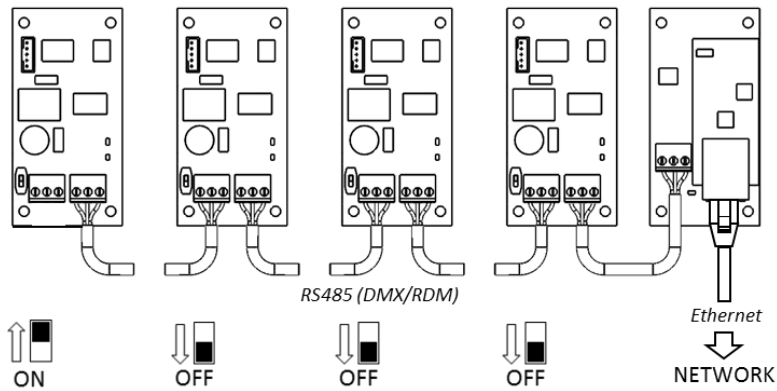

3. TEMP Control of a single enclosure via Ethernet

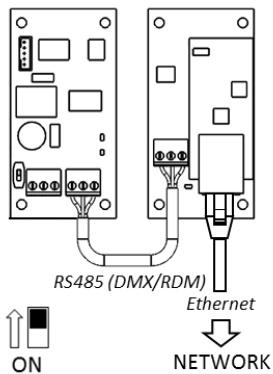

Projector Power Control using DMX512

The DEC4 controller includes a 30A 2-pole relay that protects the enclosed equipment in the event of a serious high temperature event by cutting off power. In 3-phase enclosures this is augmented by a 4-pole contactor.

You may use DMX512 (a popular entertainment industry protocol running on RS485, originally intended to control lighting system dimmers) to control power to the projector inside the enclosure. This is very useful in hot locations, where the projector may be stressed by being held in standby mode all day under hot sun. By powering the projector down it will tolerate much higher temperatures without harm.

Tempest recommends the JESE RDM-TRI interface to monitor enclosure status in any installation and control the enclosure power relay in smaller systems.

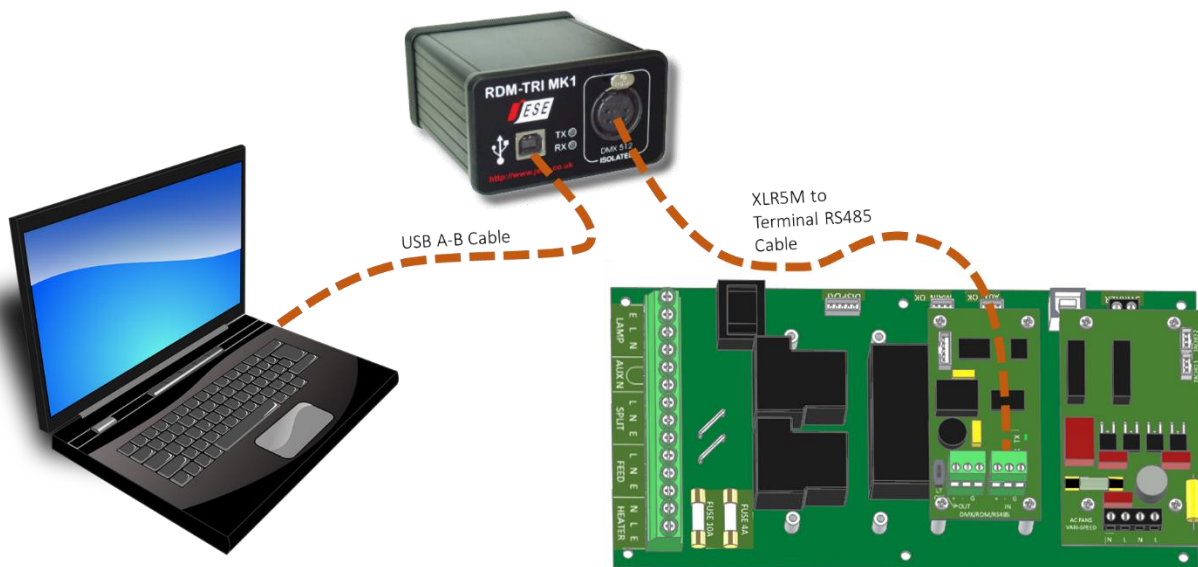
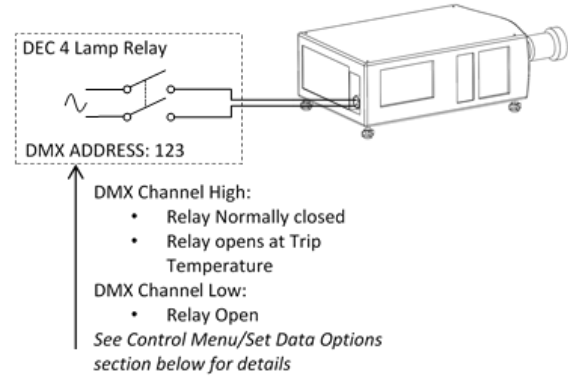

More complex installations are very likely to include some kind of show control system that will certainly include DMX control. This is the preferred method of controlling power to the projectors.

DMX/RDM Network, using JESE RDM-TRI

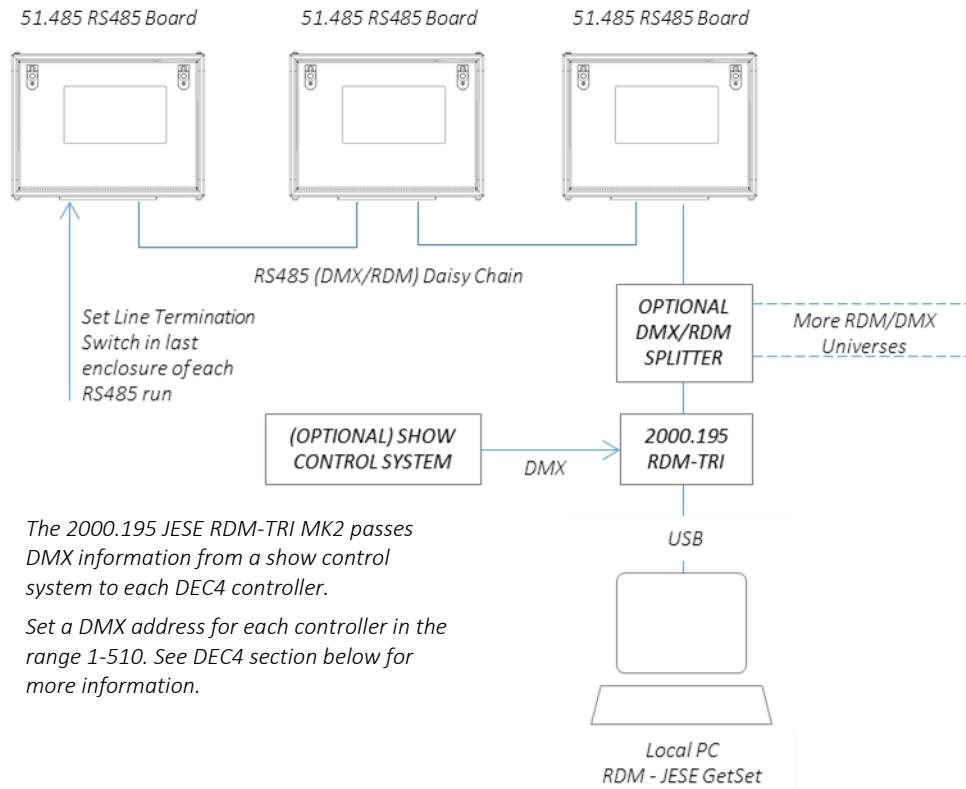

The 2000.195 JESE RDM-TRI MK2 passes DMX information from a show control system to each DEC4 controller.

Set a DMX address for each controller in the range 1-510. See DEC4 section below for more information.

Digital Enclosure Control

DEC4™ – that’s Digital Enclosure Control, fourth Generation – is the brain of your Tempest enclosure. It will maintain the internal environment in a comfortable temperature and humidity range, and prevent condensation – the real killer of outdoor equipment. DEC4 monitors internal and external temperature, humidity and lamp current at all times, and uses this information to control the enclosure’s lamp relay, fan(s) and heater(s). It can report back over an RS485 network, using the RDM protocol (Remote Device Management), or connect to your TCP/IP network for remote monitoring and management using Tempest’s TEMP protocol.

Typical DEC4 configuration, with Motherboard, fan control board and RS485 comms board

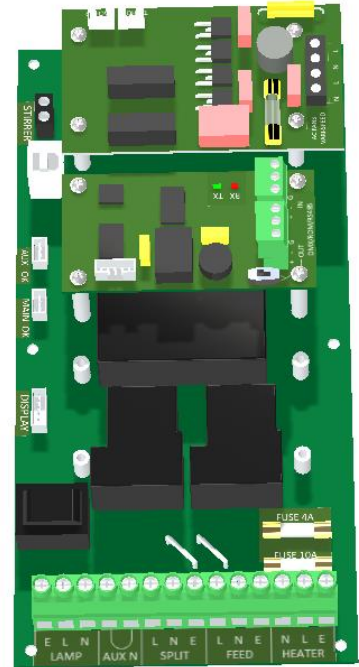

Schematic

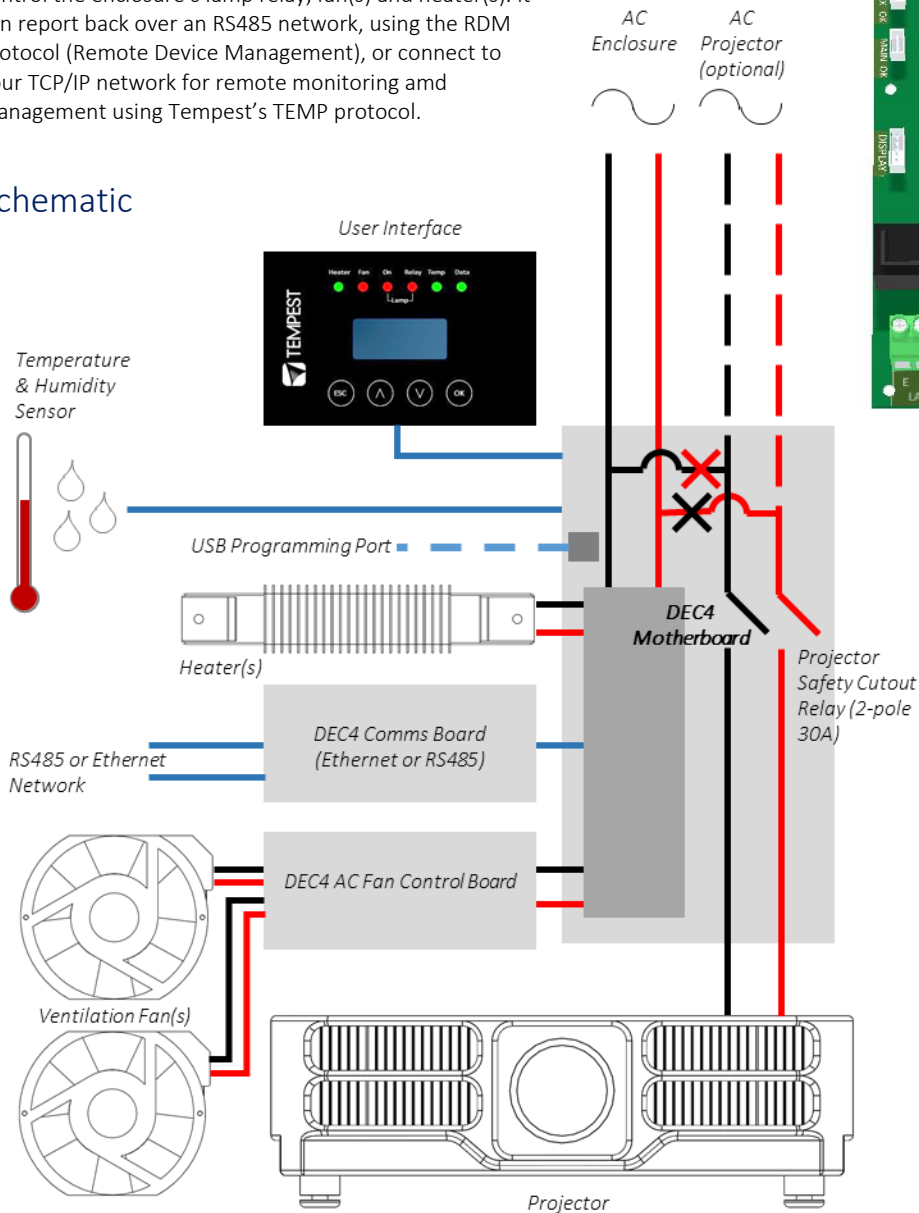

DEC4 Main Functions

Firmware Revision

This manual covers DEC4 Firmware revision 2.03.000 and higher.

To check the Firmware revision, on the User Interface menu, go to Status Display/Firmware.

1. Sense current to projector (lamp on/off)
2. Record lamp hours
3. Monitor temperature and relative humidity inside Enclosure
4. Monitor temperature outside enclosure
5. Maintain internal temperature at safe operating level
6. Maintain relative humidity within safe limits to prevent condensation
7. Isolate projector in case of unsafe temperature
8. Report status over RS485, RDM, TCP/IP
9. Maintain positive pressure (optional) 24/7 to prevent ingress of salt air and other contaminants through the exhaust path
10. Circulates air internally to prevent hot and cold spots when projector is idle

DEC 3.3's patented Goldilocks™ algorithm uses a combination of sensors, heaters and fans to maintain a safe operating temperature and a safe relative humidity level that will not allow condensation to take place.

As air is heated it is able to support more moisture without condensing, so Goldilocks uses heat to raise the air temperature inside the enclosure in the event that relative humidity approaches dewpoint.

DEC4 constantly monitors the following parameters:

- Projector/Luminaire current
- Line Voltage
- External Temperature
- Internal Temperature
- Internal Relative Humidity

Factory Settings – Data Modes

In most applications, DEC4 will operate correctly with its factory default settings, in Basic operating mode.

You do not need to do anything. Please skip to the next section.

- Standard default temperature and humidity settings
- DMX, RDM and Remote Monitoring disabled
- Best for standalone operation

If your needs are more complex, read on.



Hardware Indicators & Fuses

DEC System Control Board

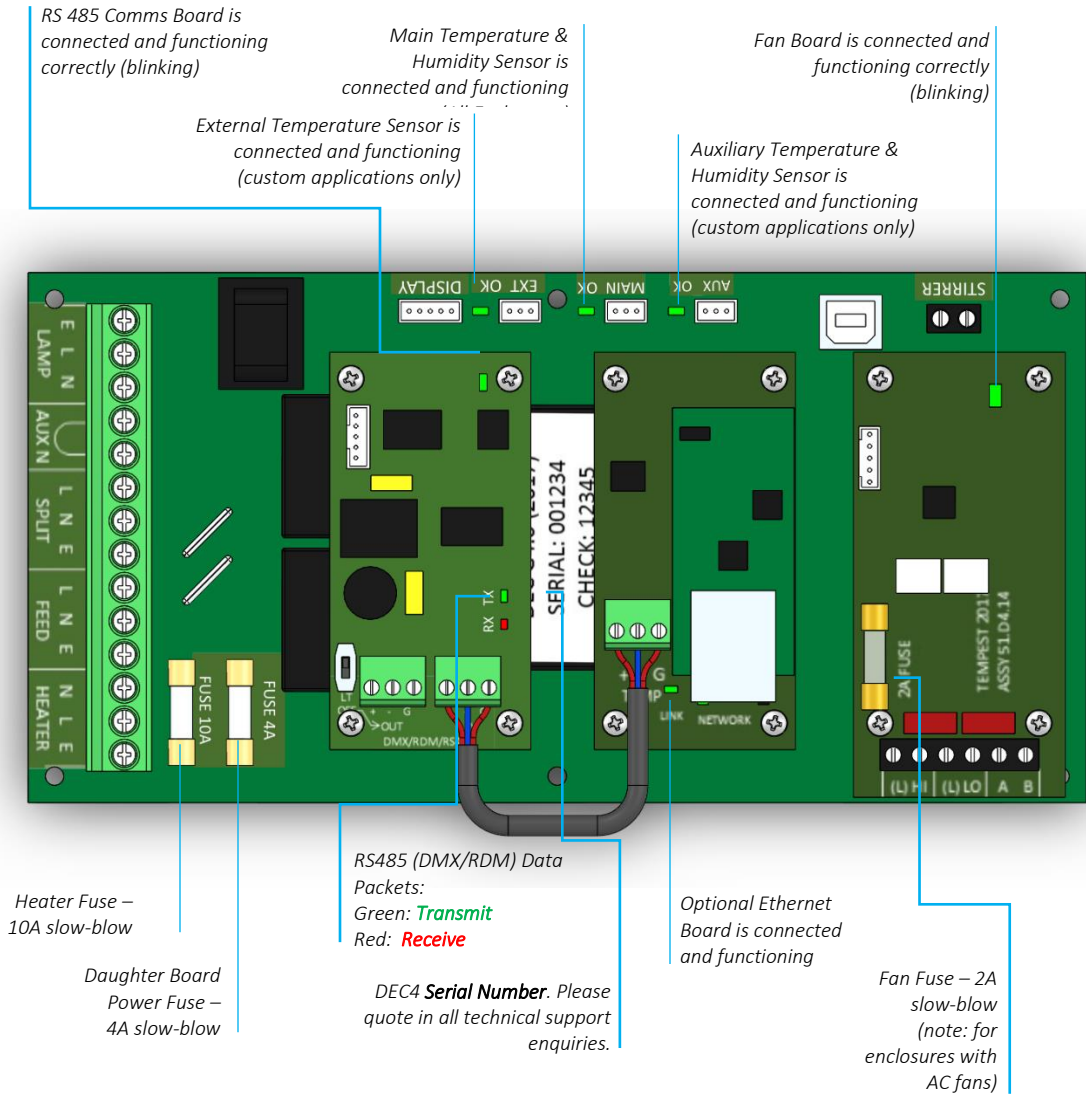

PWM Fan Transition board (up to 5 fans)

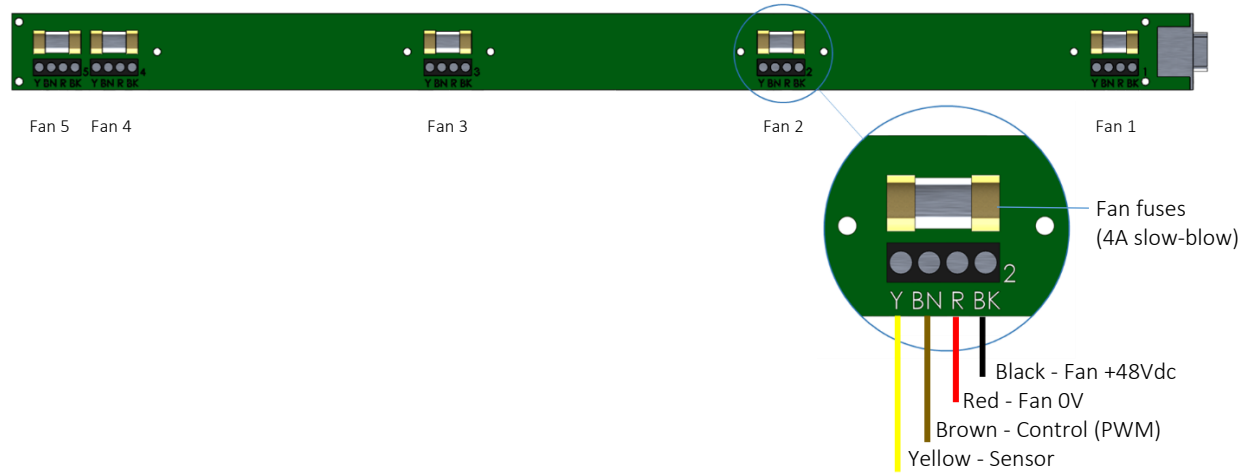

Operating Modes

RDM Only Monitor (Factory Default)

- Supports RDM monitoring over RS485 if present
- Supports TEMP monitoring if present
- RDM Status Reporting over RS485
- RDM Configuration – settings may be changed remotely or at the enclosure user interface.
- No DMX control

RDM+DMX Control

- Enclosure functions as a 1-channel DMX device, with remote control of the lamp relay
 - DMX level > 75% enables normal relay operation (normally ON)
 - DMX level < 25% disables normal relay operation (relay turns OFF)
 - This allows you to force a hard reset of the lamp relay in the event of a projector malfunction
- RDM Status Reporting over RS485
- RDM Configuration – settings may be changed remotely or at the enclosure user interface.
- Control mode is recommended for show control applications, but can be risky in live show operation, since the DMX slot used for the enclosure MUST be kept high to prevent the lamp relay from opening.

RDM+DMX Service

For trained service personnel only

- Normal operation is suspended and the enclosure functions as a 3-channel DMX device:
 - Lamp Relay (Slot 1)
 - Fans (Slot 2)
 - Heater (Slot 3)
- RDM Status Reporting over RS485
- RDM Configuration – settings may be changed remotely or at the enclosure user interface.
- ***Service mode is ONLY for troubleshooting – DO NOT use Service mode for normal operation.***

DEC4 Control Parameters – PWM Fan Control

General Description

DEC4 monitors the following factors in real time:

- a) Projector current (in amperes)
- b) Temperature (at the DEC sensor, located close to the projector main air inlet)

The following parameters are user settings that affect cooling performance and fan speed/noise:

- a) Fan Type (for Zen enclosures fan type is either 140 or 172)

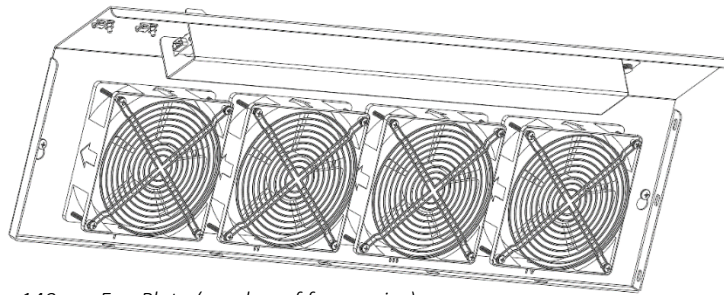

140mm Fan Plate (number of fans varies)

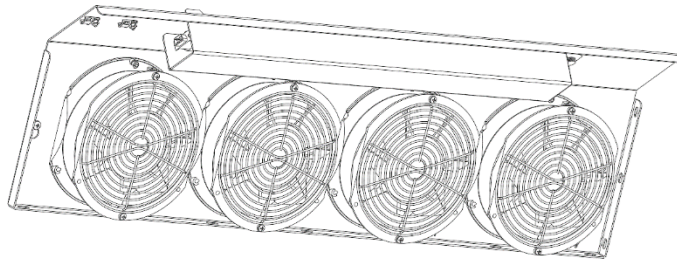

172mm Fan Plate (number of fans varies)

- b) Fan minimum duty cycle (MDC). This is the minimum speed at which the fan will run when the DEC detects the projector lamp is on (from the projector current sensor).
- c) Recovery – the rate at which fan speed changes in response to temperature changes.
- d) Upper Temperature – the target maximum temperature at the projector inlet.

When the DEC detects that the projector is running, it starts the fans at their MDC speed setting.

If the temperature increases to reach the Upper Temperature setting, the fan speed will increase to increase airflow and control the operating temperature at the Upper Temp setting.

Optimizing PWM Control Settings

Open the User Interface control menu by holding ESC and OK for 5 seconds:

Scroll down to the SET TEMP RANGES submenu, and hit OK

1. Set an Upper Temperature (UT) appropriate to the projector and application
 - a. The UT must always be higher than the expected ambient temperature at the enclosure location – for example, in an air-conditioned roomful of people, the ambient may be 25°C (77°F). Try setting a UT at, say, 30°C (86°F).
 - b. The lower the UT setting, the harder the fans will have to work. Thus, the UT setting provides control of a tradeoff between cooling and fan noise. If fan noise becomes objectionable, try increasing the UT value until the sound level is acceptable.
2. Hit OK, OK to return to the main menu.

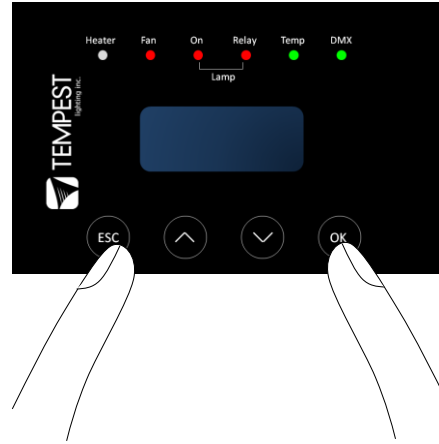

Scroll down to the SET FAN FUNCTIONS submenu, and hit OK

3. Check that the Fan Type is correct (Zen = 172 or 140)
4. Set the fan MDC (minimum duty cycle) – the actual range varies for each fan type:
 - a. Start with the lowest available MDC value. This means that when the projector turns on, the fans will run at their lowest available speed.
 - b. Because fan speed adjustments are slow (to prevent annoying background noise level changes), it is possible that the projector may heat up the enclosure faster than the fans can adjust. If the projector overheats, try again with a higher MDC setting.
 - c. Generally, you want the MDC setting to be as low as possible, consistent with the thermal characteristics of the projector.
5. Set the RECOVERY speed – this is the rate at which the fan speed changes to adjust to temperature variations – on a scale of 0 – 10. 0 is fastest change, 10 is slowest.

Control Interface

LED Indicators

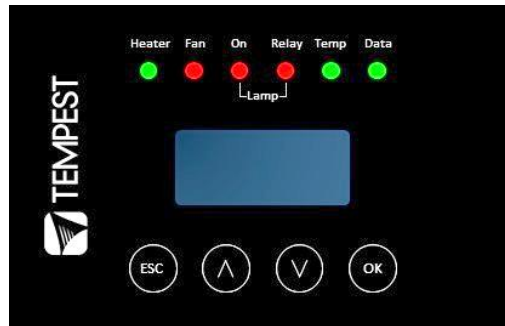

Heater	ON (Green)	Heater is ON, to maintain lower temperature level or to prevent condensation
	ON (Amber)	Enclosure is temporarily outside the Goldilocks zone, and DEC is working to restore it
Fan	ON (Green)	Lamp is ON, or Temperature is HIGH and fan is cooling enclosure. Short burst when lamp off indicates fan moving air to stabilize temp/humidity. <i>NOTE: Fan LED will not light if no fan is detected</i>
	Lamp On	Current sensing shows lamp is ON Lamp hour counter is running
Lamp Relay	OFF	Current sensing shows lamp is OFF Lamp hour counter is not running
	ON (Green)	Lamp relay is closed (normal) Projector power receptacle is energized
Temp	ON (Red)	Lamp relay is open due to over-temperature event. Projector power receptacle is isolated.
	FLASHING (Green)	Temperature is below lower temp setting
	ON (Green)	Temperature is in normal range
	ON (Amber)	Humidity is above target limit
	ON (Red)	Temperature is above top setting
Data	FLASHING (Red)	Temperature is above Trip level Projector power is isolated
	OFF	Data not used in present Mode. OR DEC4 is in RDM + DMX Control Mode and no valid data packet has been detected.
	ON (GREEN)	Good data packet received.
	ON (RED)	RDM + DMX Control Mode: Data Fail. A previously good data signal has failed.

User Interface LCD Display

The display on the Control display provides additional status information, depending on the operating mode:

RDM Only Monitor Mode

28 °C	47%	<i>internal temperature, relative humidity line voltage, lamp status</i>
209V	OFF	

RDM+DMX Control Mode RDM+DMX Service Mode

28 °C	47%	<i>internal temperature, relative humidity line voltage, lamp status</i>
209V	OFF	

Alternating with:

DMX: 001	<i>DMX Start Address DMX Status</i>
No DMX	

(Alternating DMX Display requires a DMX signal to be present)

Control Interface Operation

The Control Interface is normally LOCKED.

- To UNLOCK, hold **ESC** and **OK** together for **5 seconds**.
- You are now in the CONTROL MENU
- Use **↑↓** to scroll up and down the menu.
- Press **OK** to enter a menu item
- Use **↑↓** to set the item parameter, or to scroll to the next menu level.
- Use **ESC** to go BACK, or **OK** to confirm settings (**↵**).
- To exit and LOCK, hold **ESC** for 5 seconds.

Menu will time out and the display will lock after ten minutes.

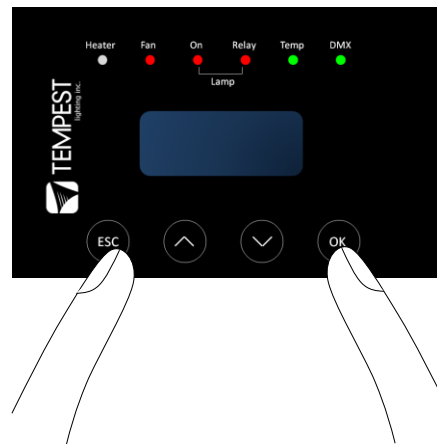

Control Menu

Set Data Options

SET DATA MODE

From the Front Panel, this menu item allows the user to check (and if necessary change) the Data mode.

RDM Only Monitor	DEFAULT	Supports RDM or TEMP if connected. No DMX Control.
RDM+DMX Service		Service mode – 3 DMX slots, starting with the DMX address set <i>Important: Please ensure that DEC4 is NOT left in Service Mode.</i>
RDM+DMX Control		DMX (set 1 address for lamp relay) plus RDM

SET DATA ADDRESS (in RDM Only Monitor, RDM+DMX Service or RDM+DMX Control Service modes)

Select a DMX starting address in the range 001 to 510

1 – Lamp Relay

In Service Mode an addition two slots are available

2 – Fan Duty Control

3 – Heater Duty Control

Note that the DMX control is designed using a SAFETY pile-on Logic. So the DMX input can only override automatic settings within safe limits.

SET DATA CURVE

DMX Curves affect the way the fixture relay is controlled in RDM+DMX Control Mode.

DMX levels are shown as %.

Response Curve 1 (default)

DMX level 0-25 Relay disabled (open)

DMX level 26-75 No change to relay status

DMX level 76-100 Relay enabled (normally closed)

Response Curve 2

DMX level 0-19 No change to relay status

DMX level 20-40 Relay disabled (open)

DMX level 41-59 No change to relay status

DMX level 60-80 Relay enabled (normally closed)

DMX level 81-100 No change to relay status

SET DATA RESPONSE

DMX Response sets a delay time before DMX Control Mode settings are acted on. Setting a response delay of a few seconds would prevent unintended fixture relay state changes in the event of a short accidental change in DMX level.

NOTE: from firmware revision 0.00.100, DEC holds last valid DMX level if DMX is interrupted.

Response Delay Values are:

No Delay (default), 1, 2, 5, 10, 15, 20, 30, 60 seconds.

Set Temp Units

Choose to display temperature values in Celsius or Fahrenheit (default Celsius)

Note that temperature settings must be entered in Celsius.

Set Temp Ranges

Set three temperature trigger points for Bottom, Top and Trip temperatures, in °C.

SET TEMP LOWER (minimum temperature to be maintained)

(default 10°C, permissible range 0-10°C).

SET TEMP UPPER (maximum desired daytime temperature)

(default 45°C, permissible range 25-50°C).

Zen and Tacit enclosures:

Adjust the UPPER TEMPERATURE setting as desired to balance cooling versus fan speed:

Lower Temperature = faster fan speed = more fan noise

Higher temperature = slower fan speed = less fan noise

SET TEMP TRIP (temperature at which load will be isolated – see note)

(default 60°C, permissible range 55-70°C).

Note: A thermal emergency is when enclosure ventilation fails with the lamp on, in which case the temperature will rise very quickly. To avoid nuisance tripping we recommend setting a higher Trip temperature, 60°C or above.

Set Max Humidity

Sets highest desired Relative Humidity: Default 85%, permissible range 80-90%.

Note that, when the projector/luminaire lamp is OFF, the enclosure heaters will switch on to raise the temperature and lower the risk of condensation. We recommend setting the highest Max Humidity that works in your location, to avoid unnecessary heater use.

Set Lamp On Point

The lamp current at which DEC detects the projector/luminaire lamp is running. Default is 1 Amp, which allows for most equipment fans and power supplies to run without changing the air in the enclosure. Lamp on point may be set in 0.1 Amp increments between 0.2 Amps and 2.0 Amps.

If the enclosure fans never turn off, the Lamp On point is probably set below the standby current draw of the projector/luminaire. Check the standby current draw on the display and set the Lamp on Current higher.

Reset Lamp Hours

Reset each time you change the lamp in the projector.

Make this a part of your maintenance instructions.

Set Fan Function

SET FAN - FAN TEST

To test the enclosure fan(s), press [OK]

The enclosure fan will run

The Display Fan LED lights green

DEC Beeps

To stop the fan test, press [ESC]

SET FAN – RUN ON

Sets the run on (cooldown) timer between 0 and 15 minutes.

Default setting: 5 minutes

SET FAN MIN DUTY (Tacit and Zen enclosures)

This sets the minimum fan duty cycle (speed)

Start by choosing the lowest value for the Fan Type selected.

Enclosure fans will run at this speed when the enclosure senses that the projector is on.

Fans will speed up as needed to maintain the UPPER TEMPERATURE selected (see above).

If the projector overheats in the first few minutes of operation, try a slightly higher minimum duty value.

Adjust the UPPER TEMPERATURE setting as desired to balance cooling versus noise:

Lower Temperature = faster fan speed = more fan noise

Higher temperature = slower fan speed = less fan noise

Minimum Duty Cycle Values (these are the PWM values required to prevent fans stalling)

Type 140:	35%
Type 172:	31%
Type 220:	27%
Type 270:	27%

SET RECOVERY

Select a setting between 0 and 10, where 0 is fastest response and 10 is slowest.

SET FAN TYPE ID (Tacit and Zen enclosures)

For Tacit 050-150, choose Fan Type **220**

For Tacit 210 and higher, choose Fan Type **270**

For Zen, choose Fan Type **140** or **172** Fan Type (check fan plate if unsure)

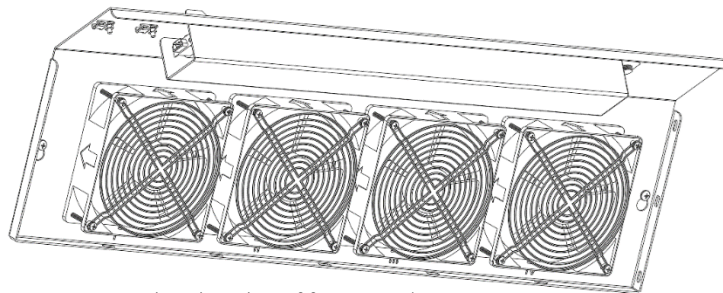

140mm Fan Plate (number of fans varies)

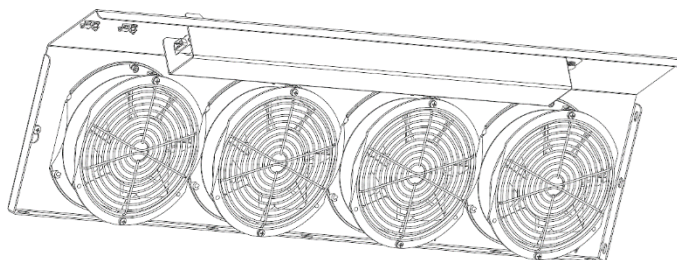

172mm Fan Plate (number of fans varies)

Status Display

View present status information, using the arrow keys to scroll through:

- a) Humidity – relative humidity in %
- b) Internal temperature, in degrees C or F
- c) External Temperature (custom enclosures with external temperature sensors only)
- d) PCB temperature (this will usually be significantly higher than air temperature)
- e) Voltage – line Voltage reaching the DEC
- f) Current being drawn by projector/light, in Amps
- g) Lamp Hours elapsed since last reset
- h) Firmware version
- i) UID – unique system ID number

DEC4 Firmware Updates

From time to time Tempest may introduce new DEC4 firmware for feature enhancements and bug fixes. Please note that the main System Control Board (SCB) and the various optional daughter boards each have their own firmware, and it will be good practice to update all firmware in an enclosure for optimal performance and interoperability.

- System Control Board firmware may be updated DIRECTLY using JESE JUST software and a USB cable, or INDIRECTLY, over an RDM network, using JESE GetSet software and a JESE RDM-TXI interface.
- Fan board firmware is extremely simple and is unlikely to require updating.
- RS485 Board (51.485) firmware may be updated over an RDM network, using JESE GetSet software and a JESE RDM-TXI interface.

All required files are available for download at <https://www.tempest.biz/tech-support/>

Direct Firmware Update (System Control Board only)

Requirements

Windows Laptop / PC, Windows XP through Windows 10 A standard USB A to B cable



Latest version of JUST application (download from <https://www.tempest.biz/tech-support/>)

A copy of the firmware file to upload (download from <https://www.tempest.biz/tech-support/>)

Powered Target DEC4 SCB

Preliminaries

1. Power up the target DEC4 System Control Board and connect the USB Port to the PC or laptop.



2. If not already installed, install the latest version of JUST. **IMPORTANT: If this is the first time using JUST, the PC MUST be connected to a live System Control Board for the installation to complete correctly.**

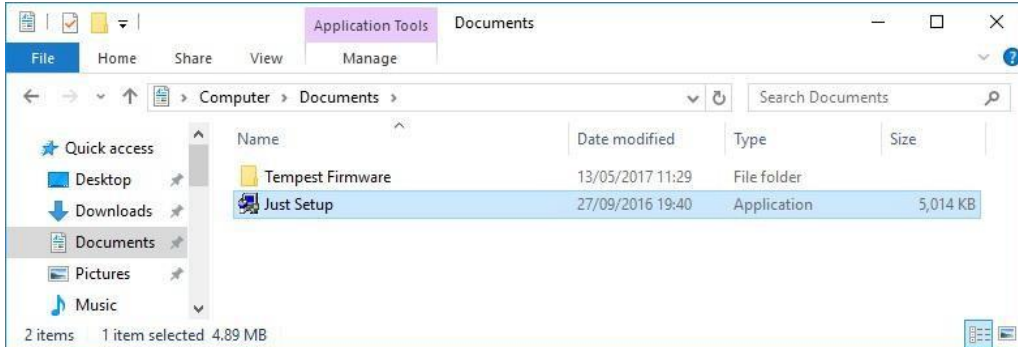

3. Run JUST and select the top left USB connection Icon. Select the DEC4 from the Connection Details option and click the connect/plug Icon. Having connected, close the connection window.

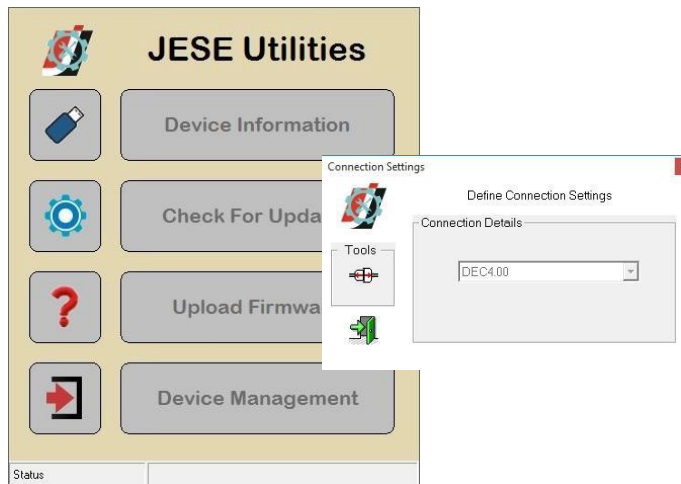

- From the main window, select the 'Upload Firmware' option. Select the file icon and navigate to the firmware file to upload



- On selection, the firmware upload will begin and run until complete.

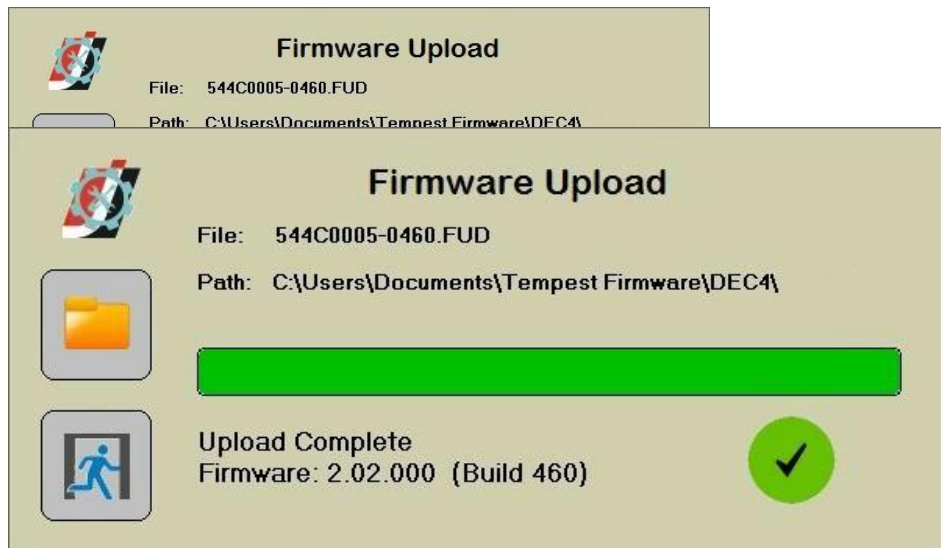

- On completion of the upload, dismiss the upload window and return to the main window.

7. The details of the SCB and firmware version may be viewed and verified by selecting the 'Device Information' option

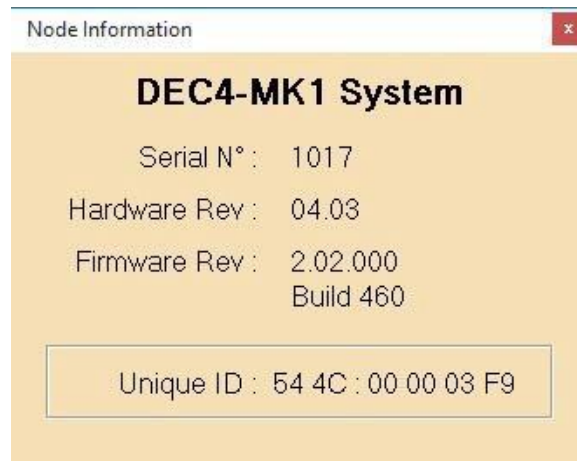

8. Close the application and disconnect the USB Cable from the SCB

- END -

Indirect Firmware Updates (System Control Board and RS485 Board)

Requirements

Windows Laptop / PC, Windows XP through Windows 10

A JESE RDM-TXI interface, programming cable and USB connection (*available from Tempest, part # 2000.195*).

An installed version of the JESE GetSet RDM configuration utility (included with RDM-TXI).

A copy of the firmware file(s) to upload, available for download from www.tempest.biz/tech_support.

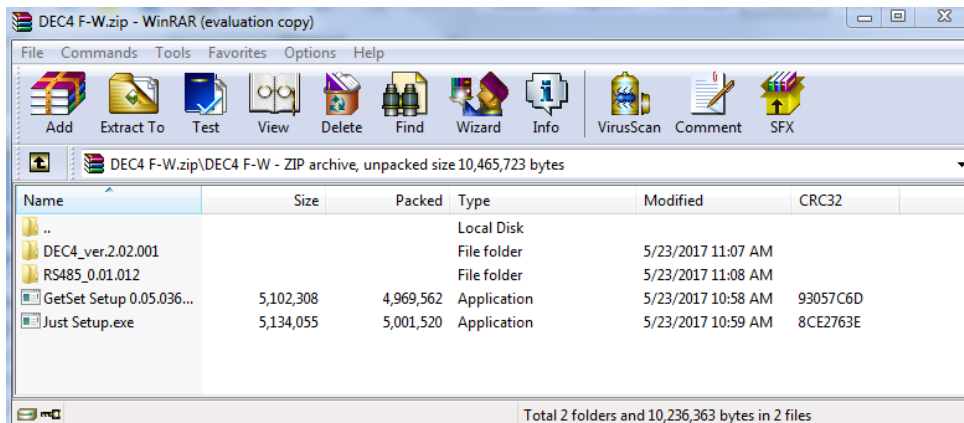
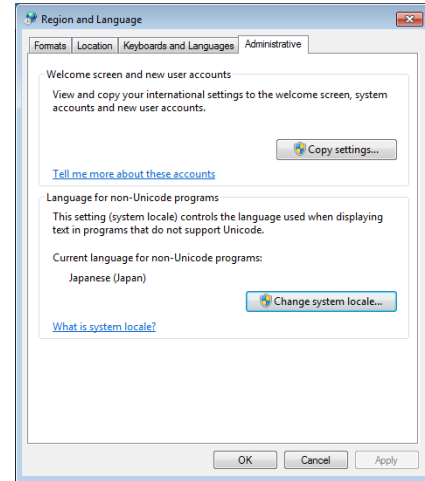

Powered Target DEC4 with 51.485 RS485 communication interface card.

Installation Procedure

1. If not already installed, install a copy of GetSet. *To ensure that the correct USB drivers are loaded, the software should be installed and the PC/Laptop re-started before connection to an RDM-TXI.*
2. If using an Asian character set, go to control panel and select Region and Language. Ensure input locale for non Unicode programs is set to a non Asian language

3. Plug your RDM-TXI in to your PC and connect to the RS485 connection on the DEC4 communications board with the fly lead, as shown below.

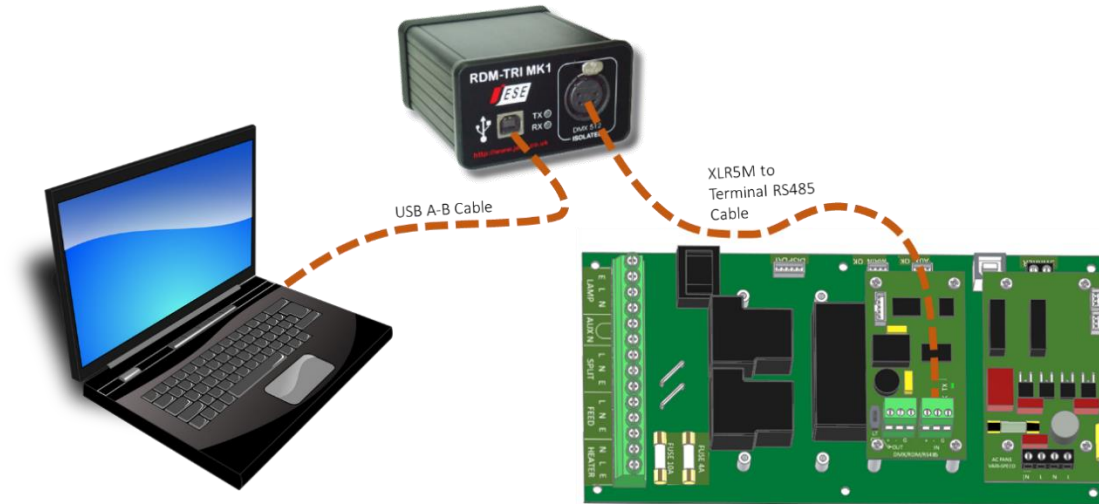

4. Power up the target SCB, ideally with mains power, or alternatively, with a USB power adaptor connected to the USB Port on the SCB.

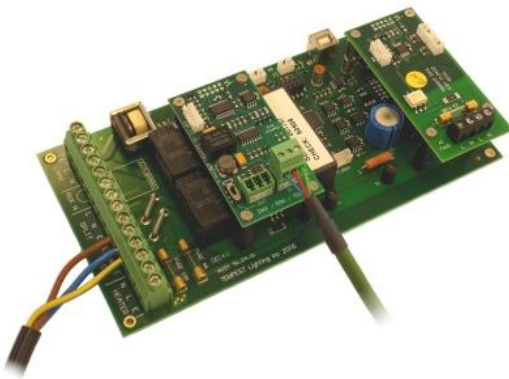

5. On older revisions of DEC Firmware, if the elected DEC 'DATA MODE' is set to 'RS485 TEMP', select 'RDM MONITOR' mode using the DEC user display. On more recent revisions of Firmware, the appropriate mode will be automatically selected.
6. Open the GetSet application, connect to the RDM-TXI and discover the DEC. To run discovery, click the Icon indicated below

- Right click on the highlighted item in the list view and select 'Reprogram' from the popup menu. This will open the firmware upload tool.

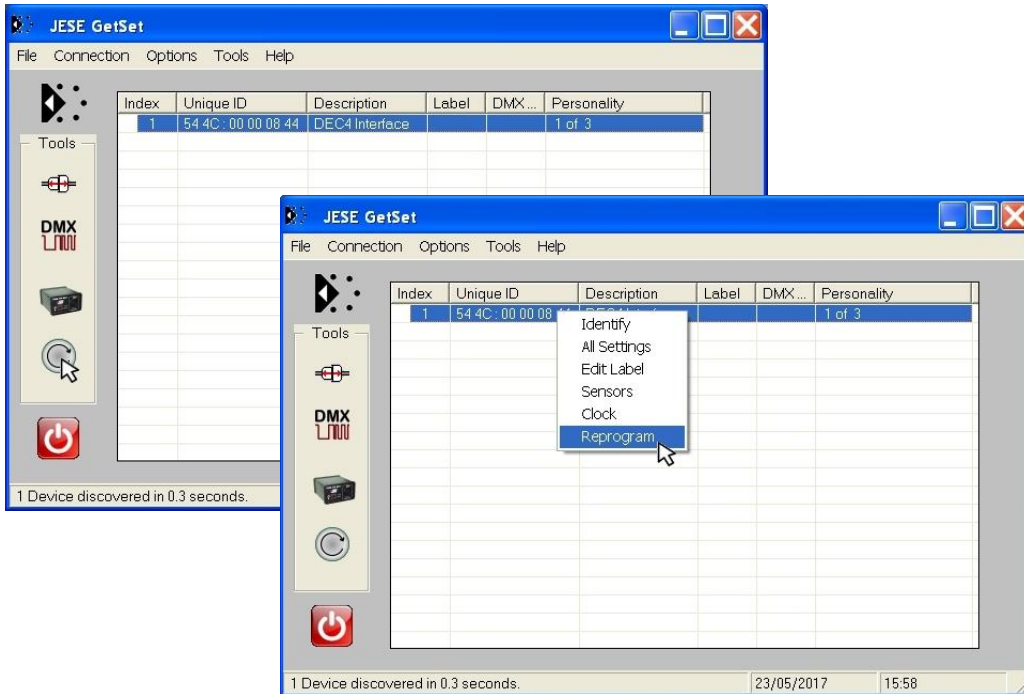

- In the Firmware upload handler, search for a file to upload by clicking the file icon. Find and select the file to load and click the Open button.

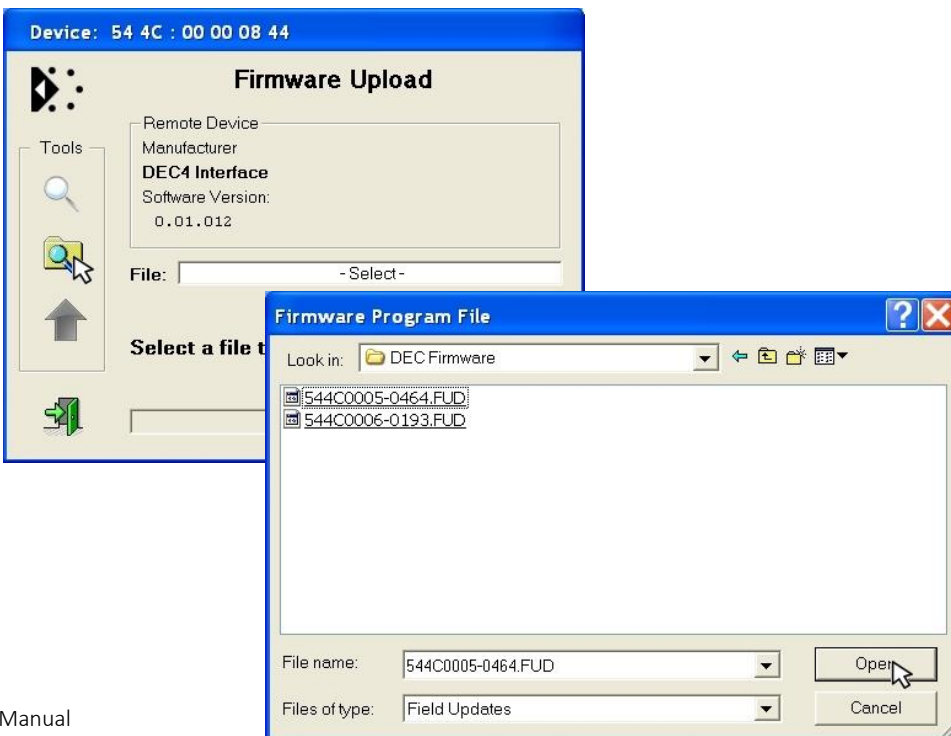

- On returning to the File upload tool window, select the green upload arrow to initiate the upload process. The upload will start.

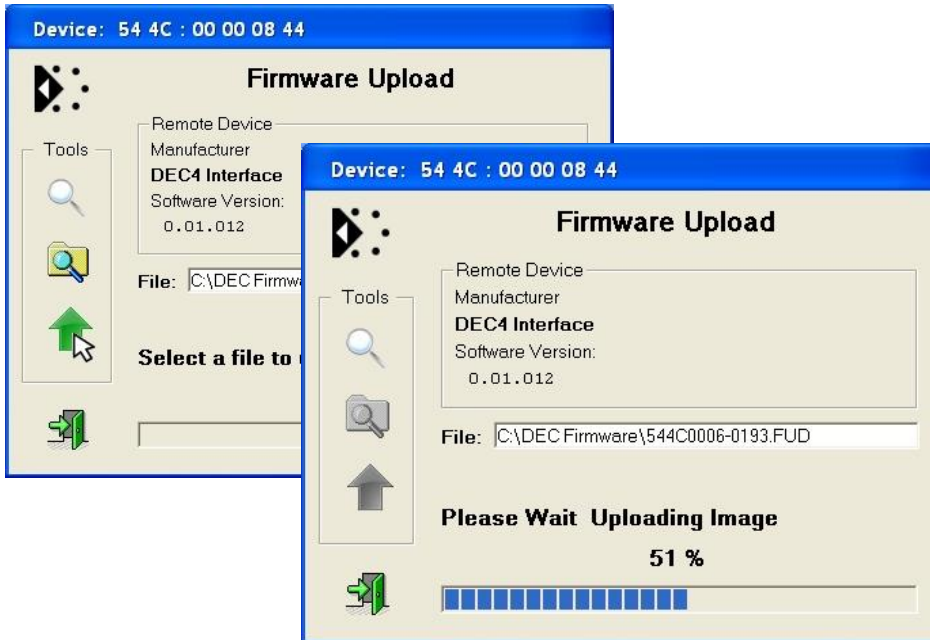

- On successful completion of upload and restart, the firmware upload is complete.

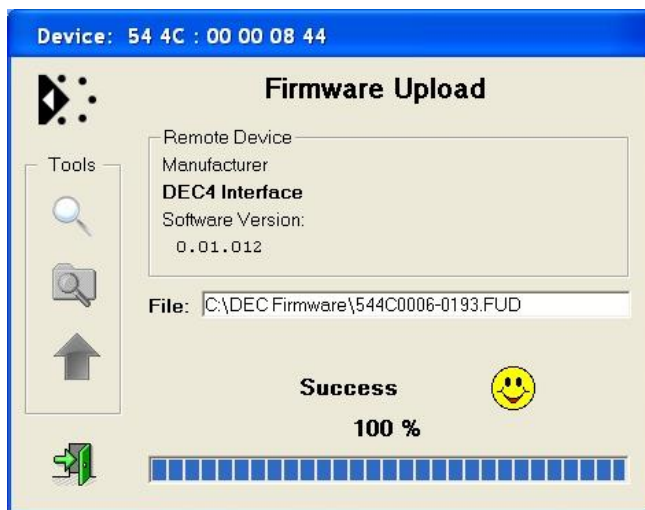

Repeat from stage 8 to 11 for each additional file to upload.

On completion of the upload, dismiss the upload window and return to the main window.

Close the application and disconnect the USB Cable from the SCB

Important:

For Remote monitoring or control, set the **DATA MODE** for each enclosure as follows:

RDM ONLY MONITOR To view status information over **RDM** or control/monitor via **TEMP**

RDM + CONTROL To monitor and over **RDM** and control the Lamp/Projector relays via **DMX**

For more information on DEC control modes see your enclosure user manual, available for download at www.tempest.biz .

End.

Mounting the Projector

Zen 050-150 Projector Mounting

1. Open the enclosure door and slide out the projector tray.
2. Remove the projector bails and the threaded rods nearest you.
3. Place the projector in position on the tray.
4. Adjust projector alignment.
5. Replace the projector rods and bails.
6. Tighten to hold the projector firmly in place.

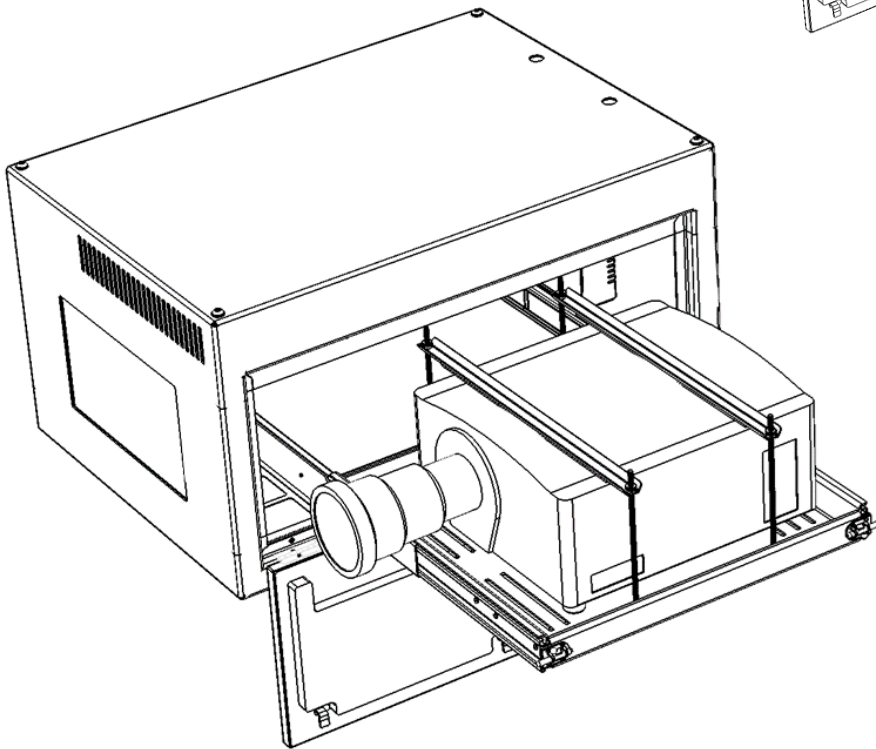
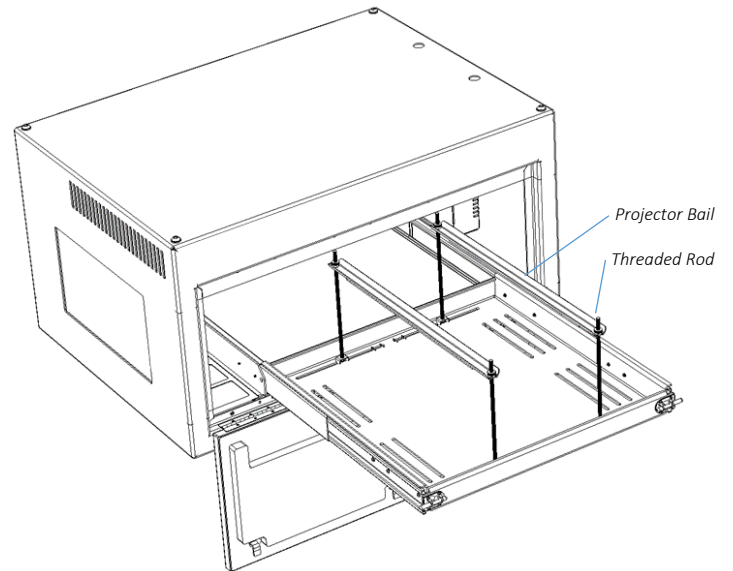

Projector Mounting Zen 210 and Up - Landscape

Pull out the projector tray and place the projector in position.

Align the projector, including any adjustment of the projector feet.

Place one projector clamp around each of the projector feet.

Use the carriage bolts, washers and nuts provided to secure the clamps to the tray.

Tip: if you need to remove the projector for service, remove the two clamps nearest you, leaving the opposite clamps in place. When you replace the projector it will be in the same location as before.

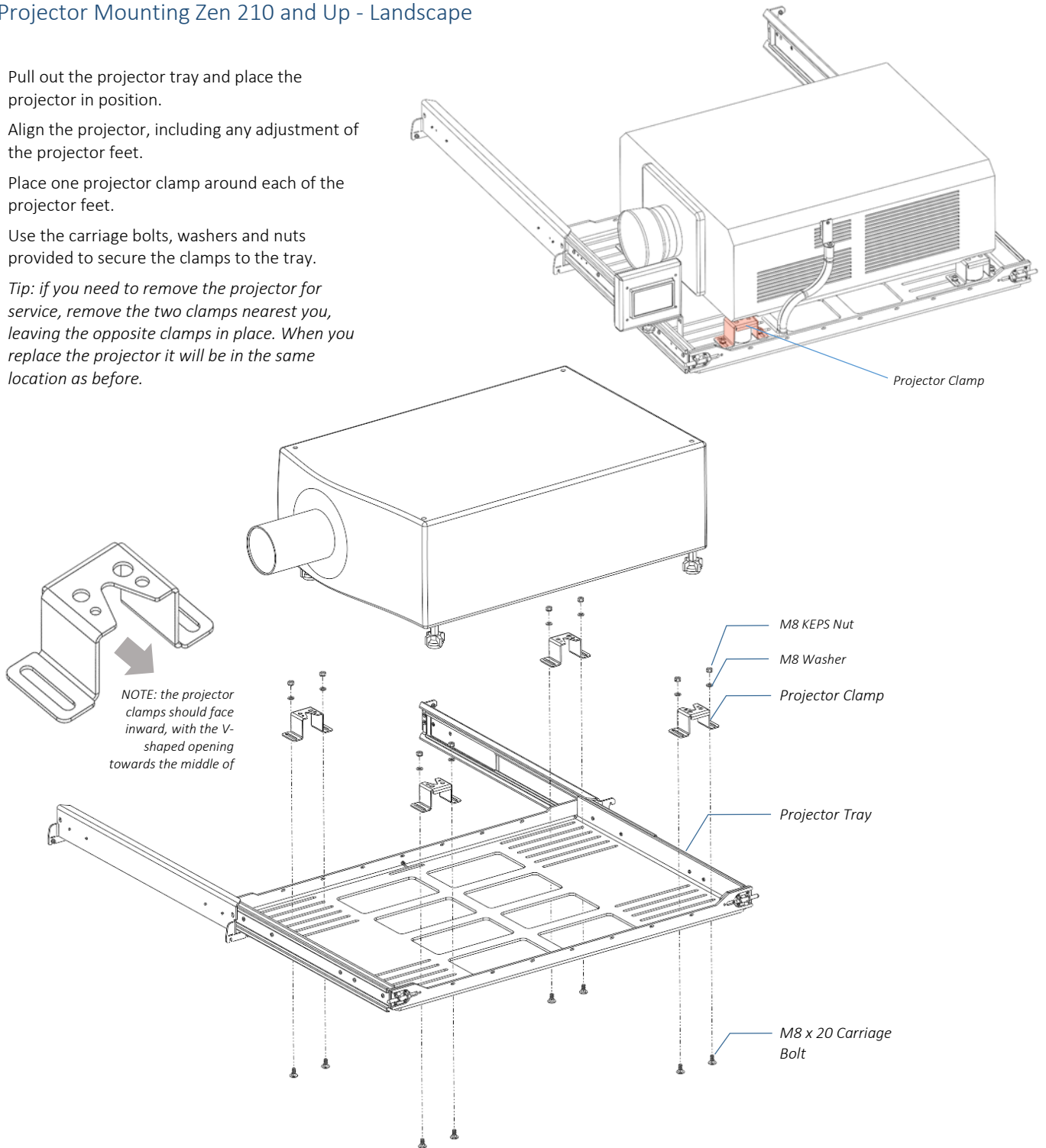

Projector Mounting Zen 210 and Up – Landscape, Feet-up

You may specify larger Tacit enclosures for feet-up (ceiling-style) projector mounting. In this case the sliding tray is mounted under the enclosure top cover, and the projector hangs from the tray.

You can secure the projector tray, using the same projector clamps, in two ways:

Recommended – fixed, but no projector feet adjustment:

1. Remove the projector feet
2. Replace each foot with one projector clamp, and an appropriate bolt (usually M10 or M12)
3. Note that each clamp has a clearance hole for M6, M8, M10 and M12 threads
4. Bolt the four projector clamps to the projector tray, using the eight M8 carriage bolts, washers and nuts provided

With feet adjustment:

1. Leave the projector feet in place and mount the projector in the same way as shown above (landscape, feet down).
2. Now, the projector feet are hanging inside the projector clamps, and you may adjust the feet for tilt and roll adjustment.

IMPORTANT: In this case, the V-shaped openings in the projector clamps MUST face inwards, or the projector may fall, causing damage and potential injury. User is responsible for any such damage caused.

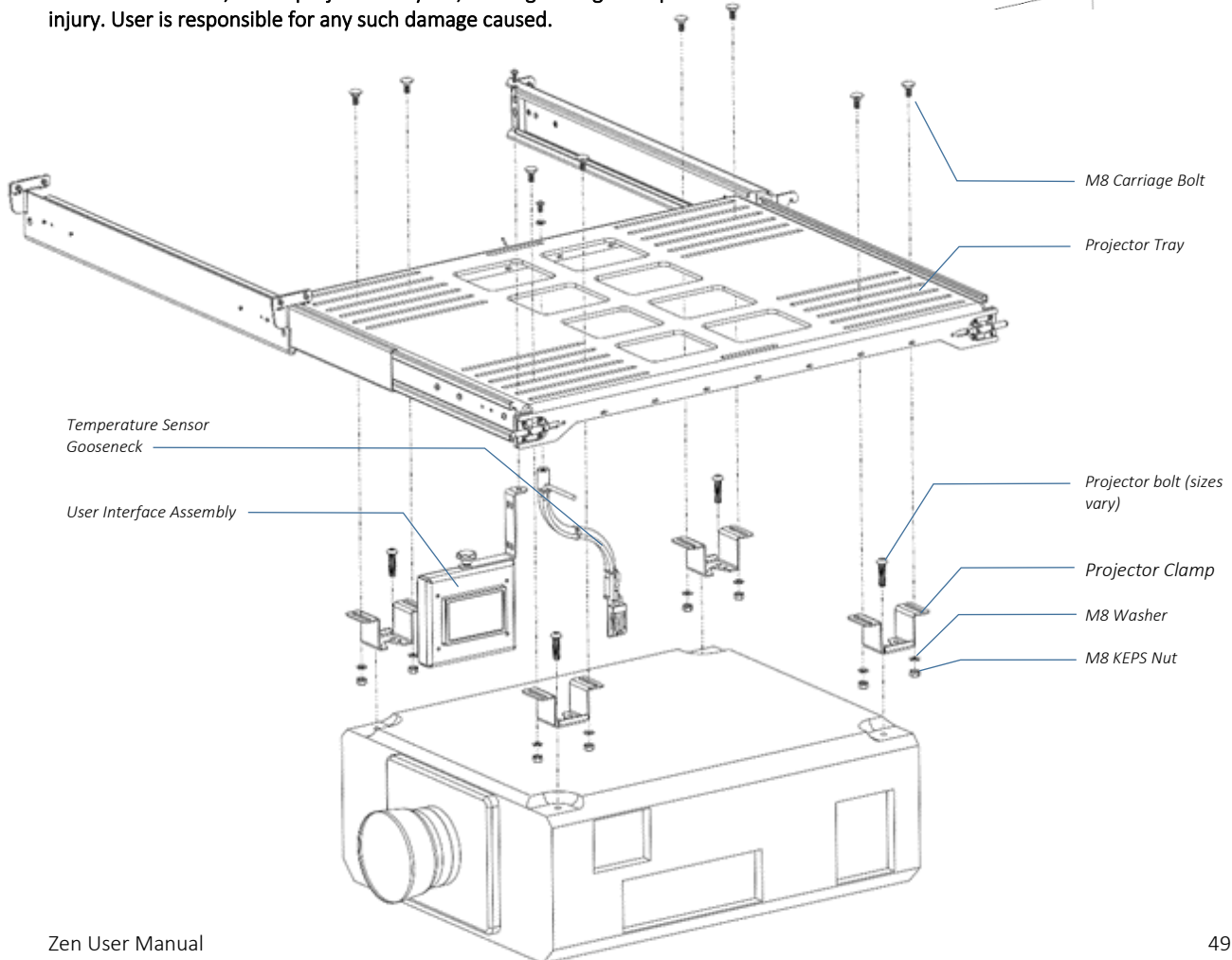
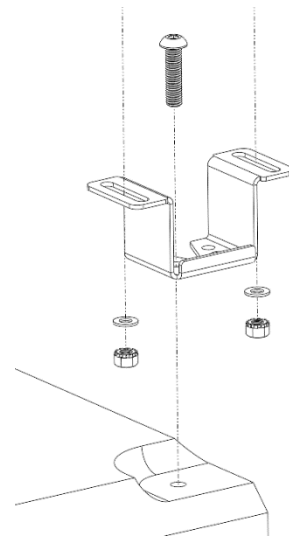

Projector-specific Mounting

All larger Zen enclosures are projector specific. Some projectors require special mounts and/or exhaust baffles. *Be sure to check for your projector in the Projector-specific information below.*

Christie D4K-40 RGB - Landscape

WARNING: This projector is HEAVY. You will need at least four people or a mechanical lifting device to install it in the enclosure. Do not attempt to lift the projector if in any doubt about your lifting capacity.

Tempest provides a special internal fan box to hang on the right side of the projector, to ensure delivery of adequate inlet airflow, required for landscape versions only.

Install the Fan box using the M12 screws provided, into the M12 threaded holes in the top of the projector, as shown here.

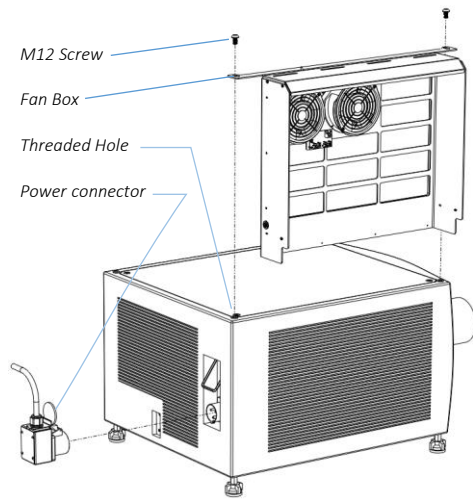

All D4K40 enclosures are supplied with a power pigtail with a 90-degree IEC309 female connector to mate to the projector power inlet.

Note: Locate the D4K40 projector feet in the round openings provided in the projector tray. This is important for optimal airflow.

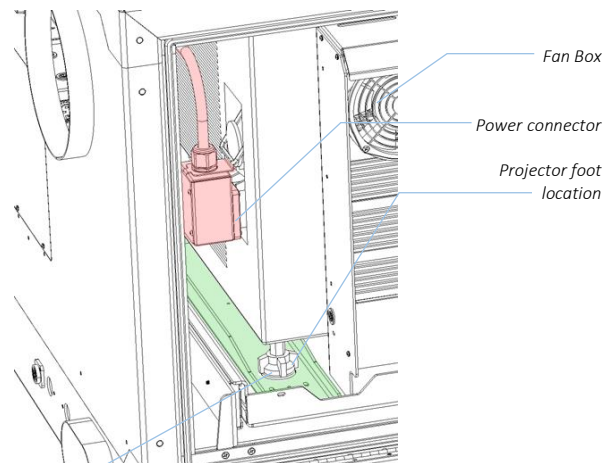
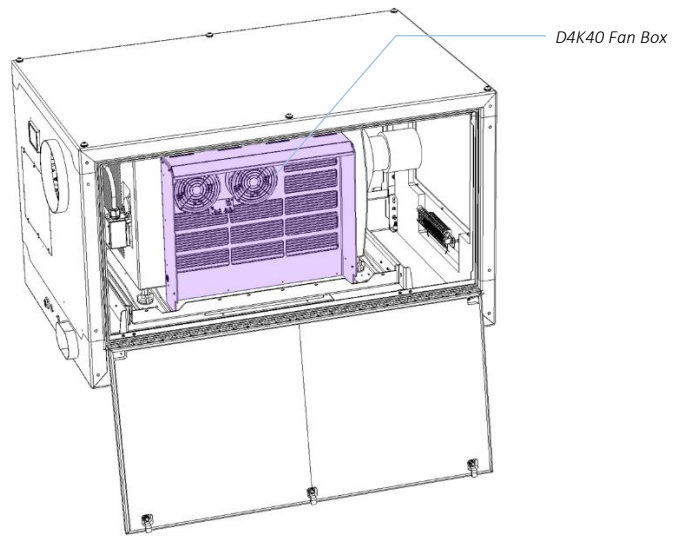

Christie D4K-40 RGB – Portrait

WARNING: This projector is HEAVY. You will need at least four people or a mechanical lifting device to install it in the enclosure. Do not attempt to lift the projector if in any doubt about your lifting capacity.

Tempest provides a custom projector mount, with the ability to install the projector either horizontal or at a tilt angle up to 6° up or down.

IMPORTANT: The projector MUST be installed air inlet down, connector panel up, as shown. Installing any other way will lead to overheating.

1. Set the projector on the ground, with the connector panel DOWN and the air inlet UP.
2. Bolt the mounting brackets and mounting bars to the M12 threaded holes in the projector chassis, as shown:
3. NOTE: the holes in the triangular bracket are set 1.5° apart, so you can set the projector either horizontal, or tilted up to 6°. It is much easier to do this now than when the projector is installed!

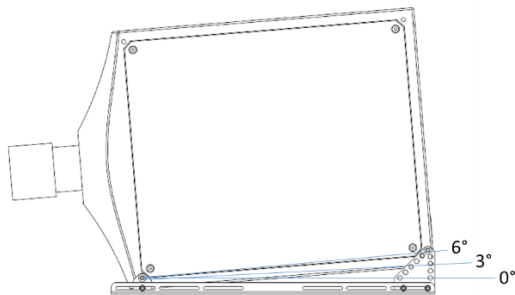

4. Now, flip the projector and set onto the enclosure tray.
5. Adjust position so the front of the lens is about 25mm (1in) from the port glass.
6. Bolt the Mounting Bars to the Projector Tray with the carriage bolts, nuts and washers supplied

For clarity, illustrations show the projector tray assembly removed from the enclosure.

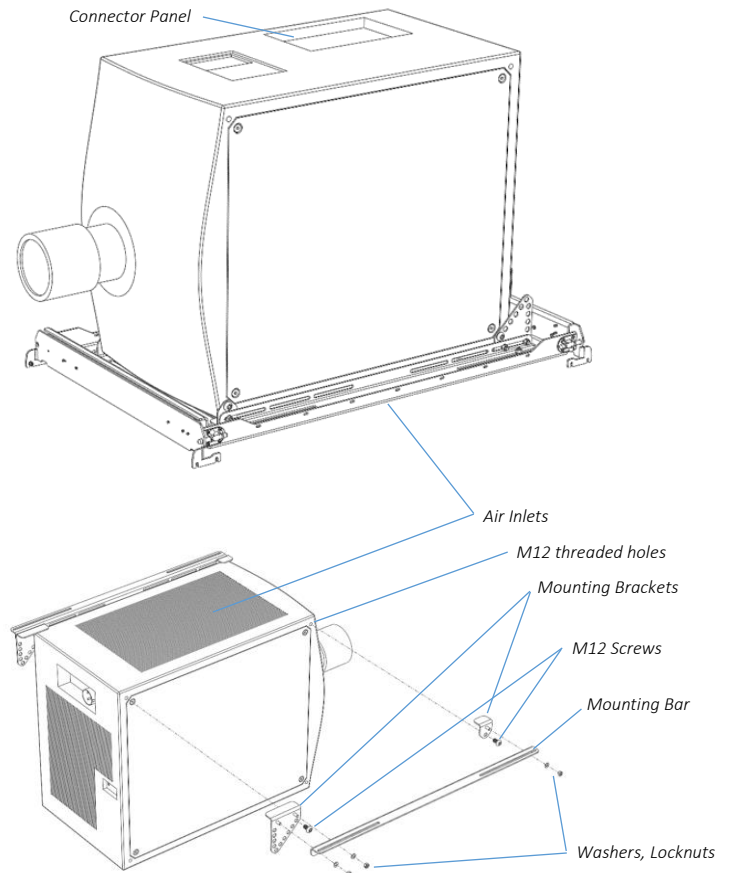

The illustrations here show the projector tilted DOWN. If you need to tilt UP, install the triangular bracket to the FRONT.

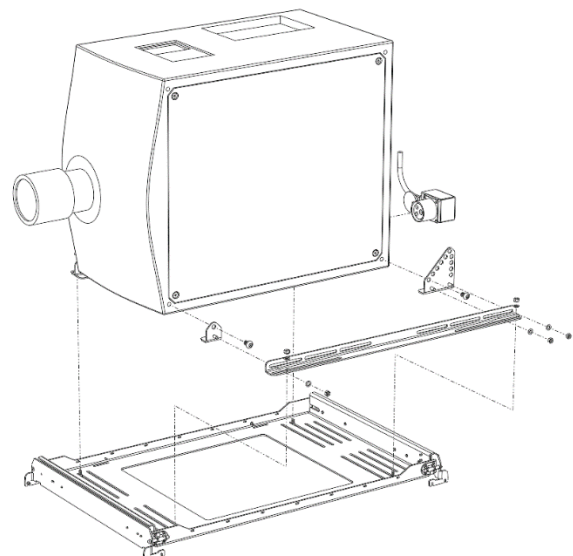

DPI Insight 4K

The lamp exhaust from this projector requires a special chimney (provided) to separate the rear inlet from hot rear exhaust air.

Adjust so that the sliding sides of the chimney are seated snugly around the projector lamp exhaust (a vertical slot in the back of the projector).

Failure to follow this step will very likely lead to hot air recirculating and serious overheating.

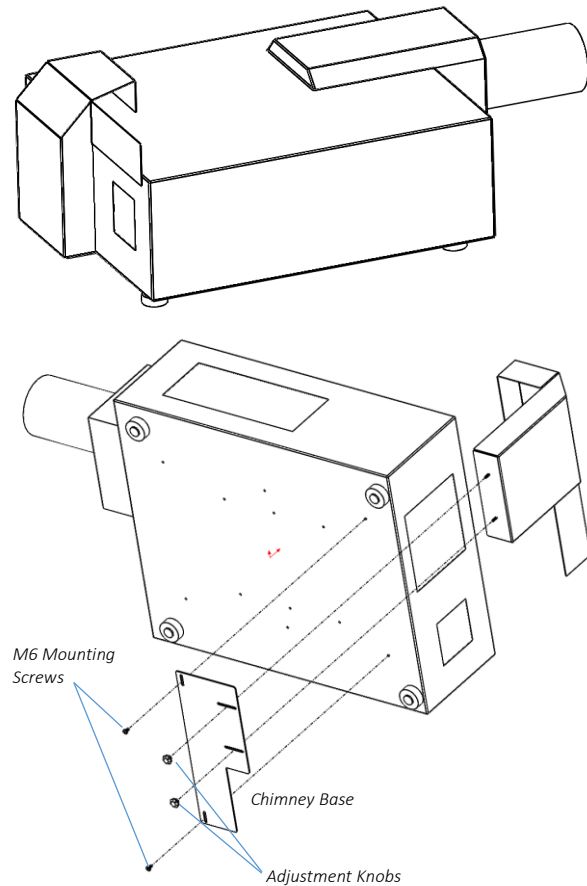

UST Projector Mounts

Most UST enclosures are completely custom, and will have their own specific mounting hardware and instructions.

Important: Locating the Temperature Sensor

It is important to position the temperature sensor as close as possible to the main projector air inlet. By doing this, Zen will accurately maintain the desired temperature (see CONTROL MENU/Set Temp Ranges section above).

The temperature sensor is mounted on a gooseneck arm, with a flexible cable, and may be mounted at any point around the projector tray.

- (1) Check the projector manual to locate the principal air inlet location for your projector.
- (2) Mount the gooseneck temperature sensor arm to a projector tray slot close to the projector inlet, using the hardware shown here
- (3) Bend the gooseneck arm so that the temperature sensor is just outside the projector inlet
- (4) Dress the temp sensor cable around the tray and tape to the projector power and signal cords

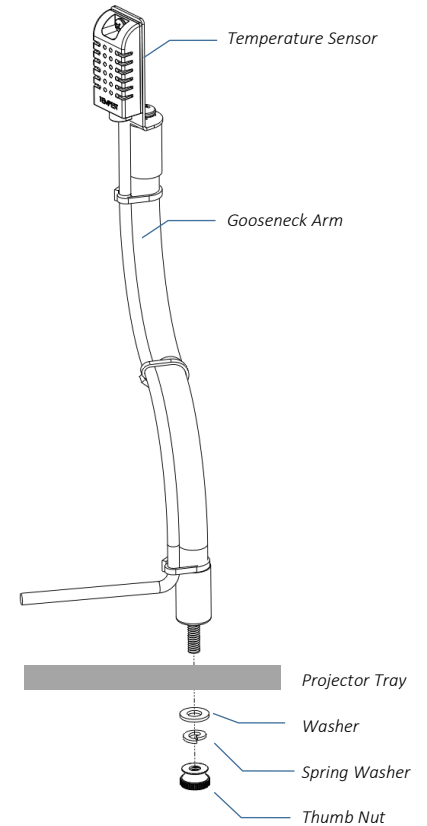
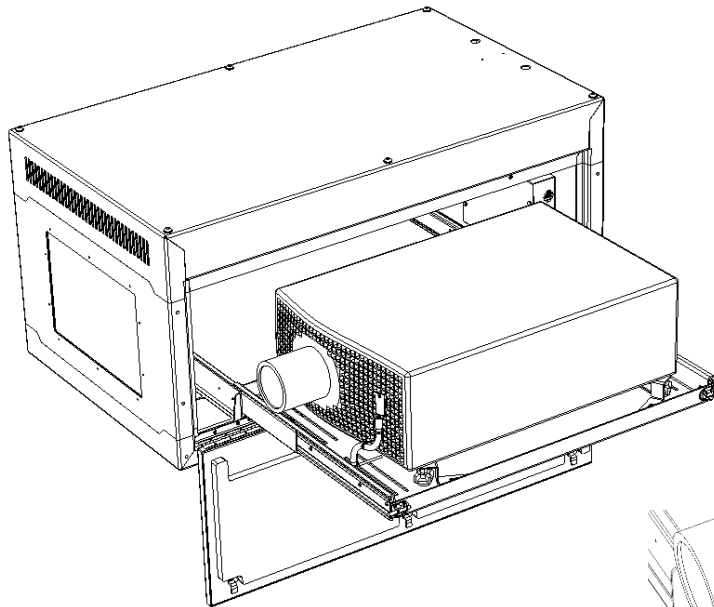

*Illustrations show Christie Boxer, with front air inlet.
ALL PROJECTORS DIFFER – check your projector manual to locate the main air inlet location*

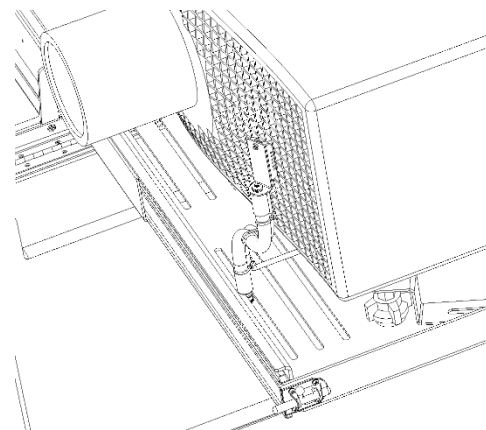

NOTE: Christie D4K40-RGB – the temperature sensor is located in the fan box on the side of the projector (landscape) or below the projector tray (portrait versions)

Important: Check Lamp-on Current

When the projector is installed and connected, check the current displayed on the User Interface, with the projector lamp(s) **OFF**. If the current is 1.0A or higher, set the Lamp On Current to a setting higher than the actual displayed.

Example:

Standby Current = 1.4A

Set Lamp-On Current to 1.7A

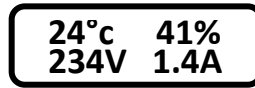

If the Lamp-on current is set lower than the projector's actual standby current, the DEC will think the projector lamp is always on, and the fan(s) will never turn off.

See Control Menu/Set Lamp-On Point above.

Important: Check Fan Setup and Temperature Range Settings

Your Zen enclosure is designed to balance fan speed (and fan noise) with airflow (cooling). You can adjust this balance using the Fan Setup and Temperature Range settings – see the **CONTROL MENU** section above.

Connect Projector and Aux Equipment

- (1) Feed the projector power and signal cables through the cable management track
- (2) Connect the projector power cable into the
- (3) Connect all cables and test projector
- (4) Install any auxiliary equipment – there is usually plenty of room under the projector tray
- (5) Connect aux equipment power supplies to the C13 outlets on the DEC box. Use the supplied rewirable C14 plugs if necessary.

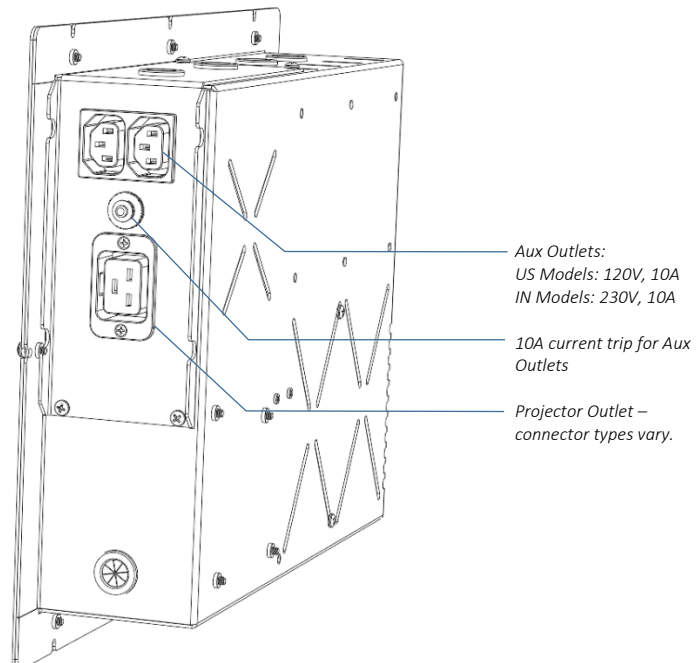

YOU MUST CONNECT THE PROJECTOR TO THE PROJECTOR OUTLET. IF THE PROJECTOR FEED BYPASSES THE DEC CONTROLLER, THE VENTILATION SYSTEM WILL NOT WORK AND THE PROJECTOR WILL OVERHEAT.

Projector Connector Types

Various Types of projector power outlets are used, in the enclosure models below:

1. IEC 60320 C13 (10A US, 15A International)
 - a. 57.050
 - b. 57.100
 - c. 57.125
 - d. 57.150

Use one outlet for the projector, the other for any aux equipment in the enclosure

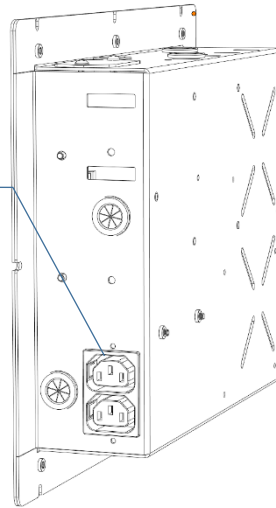

2. IEC 60320 C19 20Amp (C19)
 - a. 57.210.x
 - b. 56.250.x
 - c. Some 57.310.x
 - d. 56.320.x

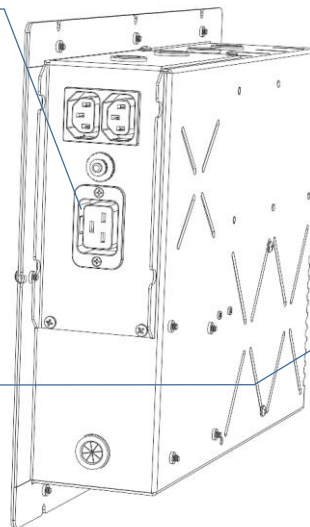

3. IEC 60309 (formerly IEC 309, often known in North America as Pin & Sleeve) 30/32A, 2P+E, 230V (blue)
 - a. Some 57.310.x

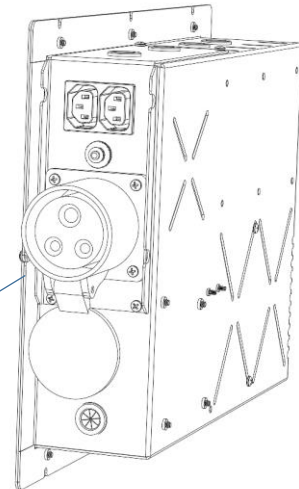

4. IEC60309 Pigtail – for Christie Boxer, D4K40 and some DPI models. Tempest supplies a space-saving line female connector assembly on a flexible pigtail, to mount directly to the projector power inlet

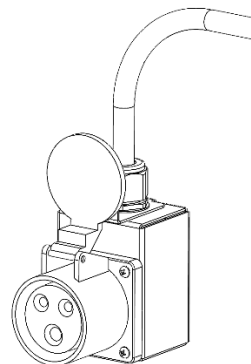

Note: contact Tempest at time of ordering to request different projector outlet types if desired.

User Interface Mount

To prevent audience distraction, Tacit and Zen user interfaces are mounted on the projector tray.

For setup and service it will be convenient to angle the display to be visible from the side when the enclosure door is open:

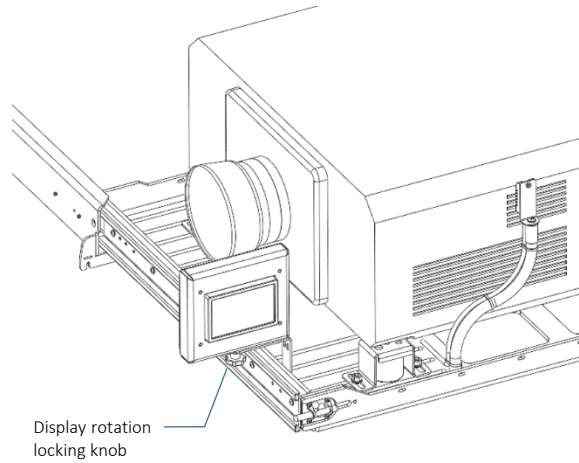

You can also rotate the display to be readily visible through the port glass:

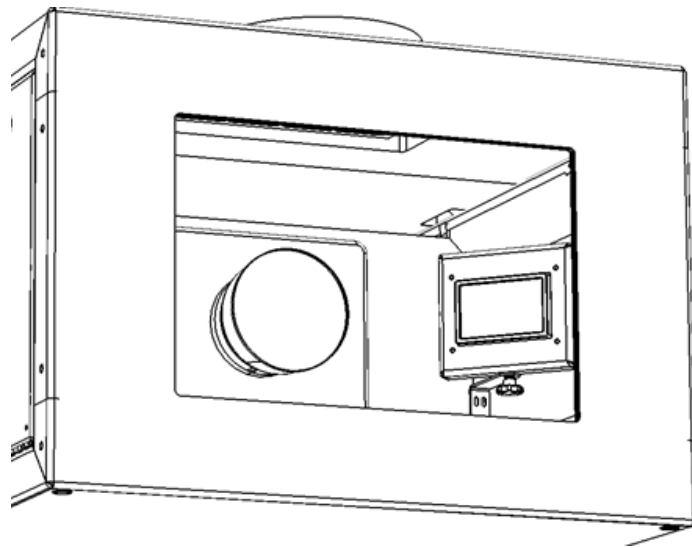

Routine Maintenance

Check the following every six months:

Clean Port Glass

Clean port glass using a window cleaning fluid or detergent.
Use a soft, lint free cloth.

Check Filter

In most cases the filter will be good for 1-2 years, but this may vary a lot, depending on the source of inlet air and how much the projector is used.

If the filter becomes clogged the temperature inside the enclosure will start to rise. This is an indication that the filter must be cleaned or possibly replaced.

Part Numbers:

57.IFL.xxx Replacement Inlet Filter Zen Series
(where xxx is the Zen model number)

To clean or replace filter

1. Remove the two filter clamp screws
2. Remove Filter Clamp
3. Remove filter
4. Wash filter with warm water and mild detergent if needed
5. Dry filter
6. Replace

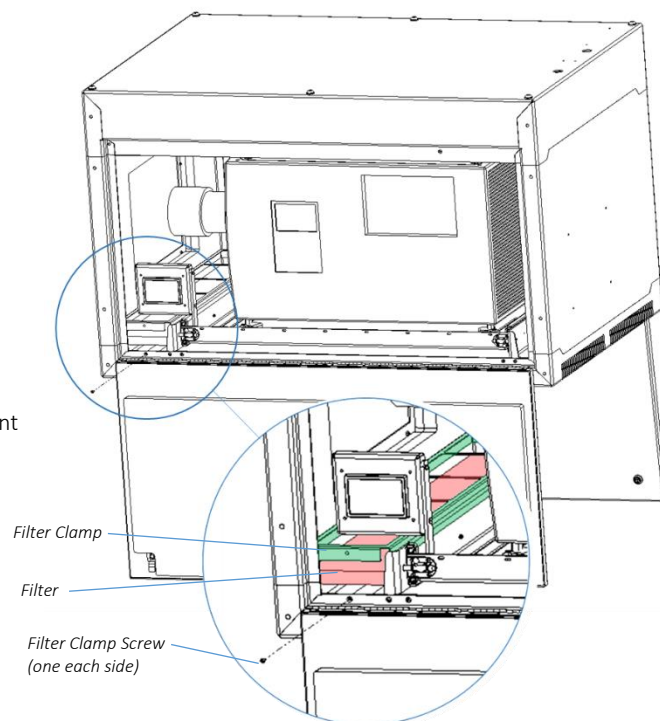

Check Temperature/Humidity Sensor

If the sensor above the port glass is defective, the controller may not operate correctly. A defective sensor will result in one of three messages appearing on the DEC user interface.

If you see any of these messages, contact Tempest for a replacement sensor.

RH: 5%
RH: 100%
RH: ####

For After Sales Support

Contact your Tempest dealer or email info@tempest.biz

Troubleshooting

Projector does not have power:

1. Check Projector power switch
2. Check projector is plugged into DEC4 projector outlet
3. Check that enclosure feed circuit is on
4. Check DEC4 User Interface leds are on. If feed circuit is on and UI leds are off, check feed wiring to DEC terminals and meter DEC4 projector outlet for power
5. If UI lamp led is on and DEC4 projector outlet is live, there is a projector fault.

Enclosure overheats:

1. **Is the projector connected to the DEC4 projector receptacle?** If the projector is powered independently the controller has no way to know when to turn on the exhaust fans!
2. Is the filter clogged or obstructed?
3. Check that the Fan led on the UI is on when the projector is running. If not, then the projector is probably not connected to the DEC (see 1).
4. If the fan led is on, check that the fan is running. If not, check fan wiring. If wiring is ok, fan may be faulty.
5. Check the UI display for RH (relative humidity) message. If display reads RH 5%, RH 100%, or RH###, there is a sensor fault. Contact Tempest for a replacement sensor.

Dirt/Debris inside enclosure

1. Filter is either missing or damaged?
2. Filter is not properly seated
3. Side panels or back door is not firmly latched

Fan LED is on but fans do not operate

The exhaust fan is protected by a 20mm 4A slow-blow fuse on the DEC4 motherboard, and a secondary fuse on the fan board. In very exceptional cases it is possible that either fuse could fail. Check visually.

The fuse is protected with a clear resin sealant and soldered to the circuit board. With care, you can desolder the fuse and replace it, but we recommend replacing the DEC4 motherboard to maintain the integrity of the board's conformal coating.

Heater LED is on but heater does not operate

The heater is protected by a 20mm 10A slow-blow fuse on the DEC4 motherboard. In very exceptional cases it is possible that it could fail. Check visually.

The fuse is protected with a clear resin sealant and soldered to the circuit board. With care, you can desolder the fuse and replace it, but we recommend replacing the DEC4 motherboard to maintain the integrity of the board's conformal coating.

None of the above?

Contact info@tempest.biz

Warranty

INSPECTION/WARRANTY/RETURNS.

A. Customer, at its sole expense, shall inspect all Goods promptly upon receipt and accept all Goods that conform to the specifications or catalog. All claims for any alleged defect in or failure of the Goods or Seller's performance to conform to the Contract, capable of discovery upon reasonable inspection, must be set forth in a written rejection notice detailing the alleged non-conformity, and be received by Seller within thirty (30) calendar days of Customer's receipt of the Goods. Failure by Customer to notify Seller of the alleged non-conformity within thirty (30) days will be conclusive proof that the Goods have been received by Customer without defects or damage, and in the quantities specified on the bill of lading and shall constitute an irrevocable acceptance of the Goods and a waiver of any such claim in connection with the Goods.

B. Seller warrants to Customer only that the Goods will be free from defects in material and workmanship at the time of delivery and, subject to the exceptions and conditions set forth below, for the following period (the "Warranty Period"): twelve (12) months from the date of shipment by Seller. Seller may provide additional years of warranty coverage beyond 12 months, at the rate of 2.5% of the net sale price per year, up to a total of four additional years' coverage beyond the standard 12 month warranty period. Seller will remedy a defect as set forth in paragraph 7 D, below, (the "Warranty"). The Warranty is subject to each of the following exceptions and conditions:

1. Customer must promptly (and in all events within the Warranty Period) notify Seller of any alleged defect in a written notice (the "Notice") which shall set forth the quantity, catalog number, finish, original purchase order number, Seller's invoice number on which Goods were originally billed and a statement of the alleged defect, along with digital photographs showing such defects where feasible.

2. The Warranty shall not apply: (i) to any claimed defect that was capable of discovery upon reasonable inspection and deemed to be waived under paragraph A, above; (ii) to any Goods that have been subject to misuse, abnormal service or handling, or altered or modified in design or construction; (iii) to any Goods repaired or serviced by any person other than Seller's authorized service personnel or to Goods installed other than according to installation instructions, or (iv) with respect to normal wear and tear.

3. Seller makes no Warranty with respect to parts or components that are not the product of Seller, and specifically makes no warranty whatsoever for equipment housed inside enclosure products manufactured by Seller.

4. The Warranty is Seller's exclusive warranty with respect to the Goods. Seller makes no warranties, guarantees or representations, express or implied, to Customer except as set forth in this section. ALL OTHER WARRANTIES, EXPRESS OR IMPLIED, INCLUDING, WITHOUT LIMITATION ANY IMPLIED WARRANTY OF MERCHANTABILITY OR OF FITNESS FOR USE OR FOR A PARTICULAR PURPOSE, ARE HEREBY EXCLUDED AND DISCLAIMED.

C. Seller will accept the return of Goods properly rejected under paragraph A, above, or as to which Notice of an alleged breach of Warranty has been timely given and such Goods may be returned to Seller, freight prepaid, but only upon Customer's receipt of Seller's written return material authorization ("RMA") and shipping instructions. The RMA shall be void if the Goods are not received within 45 days after issuance of the RMA. No deduction or credit in respect of any rejected or returned Goods shall be taken until Customer has received Seller's further written deduction or credit/authorization following Seller's inspection to confirm nonconformity or defect. Seller will charge to Customer any and all costs incurred by Seller in connection with the handling, shipping, inspection and disposition of any returned Goods that are determined by Seller not to have been nonconforming upon Delivery or as to which the warranty hereunder is not applicable.

D. UPON ANY PROPER RETURN PURSUANT TO PARAGRAPH C, ABOVE, WHETHER IN CONNECTION WITH A REJECTION OF GOODS OR AN ALLEGED BREACH OF WARRANTY AND BASED UPON THE CONDITIONS SET FORTH IN THIS PARAGRAPH 7, SELLER AGREES THAT IT WILL, AS THE SOLE AND EXCLUSIVE REMEDY UNDER THE CONTRACT OR OTHERWISE, FOR ANY NONCONFORMITY OR BREACH OF WARRANTY, AND AT SELLER'S SOLE ELECTION: (i) REPAIR SUCH GOODS; OR (ii) REPLACE SUCH GOODS.

Appendix – TEMP Protocol

AVAILABLE TO SPECIAL ORDER

Tempest can optionally provide a firmware load that facilitates TEMP over RS485, suitable for interfacing to an Ethernet adapter. TEMP is a lightweight proprietary ASCII based protocol, intended for rapid integration into management systems. With TEMP and a suitable RS485 to Ethernet adaptor connected to the DEC DMX connectors, your DEC may be configured and monitored over an IP network.

Please contact factory for ordering information.

Physical Layer

1. EITHER: Use a 51.EN Ethernet daughter board plugged directly to the DEC4 motherboard, connected to your TCP/IP network.
2. OR: Use a 51.485 RS485 daughter board on each of a number of DEC4 motherboards, connected in a daisy-chain, and use a 51.EN Ethernet board on the first DEC4 to connect to your TCP/IP network.

Developer's Guide

Download the Developer Guide from www.tempest.biz/tech-support.