



Zen
Hush
Projector
Enclosures
5-50K



Zen Hush Projector Enclosures

Tempest is the world's leading manufacturer of large format indoor projector enclosures for noise attenuation in presentation suites, digital cinema, live theatre and concert venues — any noise-sensitive indoor space.

Until now, Tempest's Whisper and Tacit enclosures achieved excellent noise attenuation

through the use of cooling fans located in a remote location, so that their noise is not disturbing to the audience.

The remote fan strategy delivers excellent acoustic performance, but may not be feasible for

installation in some venues, including historic theatres, concert halls and museums, where new ductwork may be prohibited.

Now, Tempest Zen enclosures offer a standalone solution, with noise attenuation very close to remote fan levels, but without the need for inlet or exhaust ducts.



Zen 57.210, shown here with a Panasonic PT-RQ35K projector.

Excellent projector access from either side.

zen : a state of calm attentiveness in which one's actions are guided by intuition rather than by conscious effort.

Webster's Dictionary

Integral Cooling

Inlet air enters through the base, through an inlet labyrinth made from fire-resistant melamine acoustic foam. It then passes through an electrostatic dust filter before reaching the projector.

Exhaust air similarly passes through an exhaust labyrinth above the projector chamber and exits above the enclosure port glass.

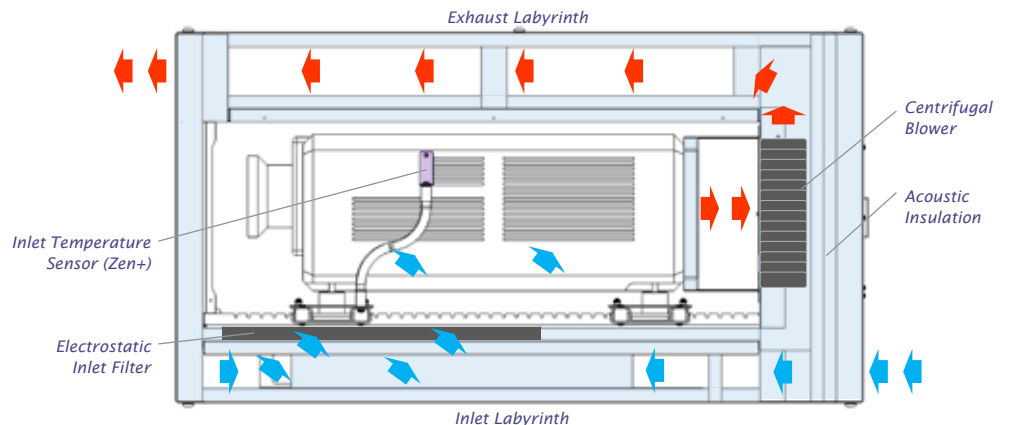

Zen Hush Projector Enclosures

Now Zen is available in two trim levels — both with the same excellent construction and noise attenuation properties.

Standard Zen has a powerful 4-speed AC centrifugal blower behind the projector — set the desired speed and airflow starts automatically when the thermostat in the projector exhaust detects a temperature rise.

You can choose a fan speed that provides the best tradeoff between projector temperature and sound pressure level.



Simply preselect one of standard Zen's four fan speeds - the thermostat in the projector exhaust airflow starts the blower as soon as the projector comes out of standby.

Zen+ goes further — Tempest's patented DEC4 controller brings you a host of additional control and monitoring features, with a variable-speed DC blower with 1% speed increments for total control of cooling and acoustic performance. Zen+ includes projector inlet temperature sensing, overtemp protection, and optional networked monitoring using **Tempest System Manager**.



Zen+ gives you fan speed control in 1% increments, temperature sensing, overtemp protection, remote monitoring and more...

Projector Types

We can build you a Zen enclosure for almost any projector/lens combination — but this is important: to get Zen's super-low sound levels it's vital that the projector exhaust mates snugly to the foam pad on the front of the exhaust blower.

Most projectors exhaust to the rear, but those emitting hot air to the front or sides will be better suited to a Tempest Whispr or Tacit enclosure.

Zen Custom

Most Zen enclosures are 'vanilla' landscape. But we know that you'll be needing portrait and UST versions too, and we deal with these on a case-by-case basis — just contact us and we'll be a part of your design team.



Zen or Zen+...

	Zen	Zen +
Aluminum Construction	✓	✓
Fire resistant Insulation	✓	✓
Rigging Hardware	✓	✓
Projector Service Access	✓	✓
Fan Speed Control	4-speed	Variable Speed
Fan Control	Thermostat	DEC 4 Controller
Thermal protection		✓
Inlet Temp Monitor		✓
User Interface Display		✓
Remote monitoring		✓
Inlet Air Filter	✓	✓
Installation wiring access	✓	✓
Top or Rear wiring ports	✓	✓
Optical Grade Port Glass	✓	✓
Security Locks	✓	✓
Projector pan/tilt/roll Adjustment	✓	✓
Projector position lock	✓	✓
Projector Mount - Vibration Dampers	✓	✓

Quick Compare

We recently tested Zen against two leading European competitors. See the results [here](#).

Zen Hush Projector Enclosures

Zen and Zen+ are the ONLY true professional grade installation standalone hush enclosures designed and tested to meet or exceed the expectations of architects and acousticians for the most stringent noise-sensitive environments.

Zen is not a wooden touring box adapted for use in auditoria. Its pedigree is Tempest's unique experience designing and building projector enclosures for the most exacting permanent installations — there are thousands of Tempest enclosures out there working every day, some for more than a decade.

Tempest works closely with all the leading video projector manufacturers, and all Tempest enclosures for projectors 20,000 lumens and up are tested and approved with the intended projector before a single one is shipped. Your projector warranty is safe with Tempest.

Rigging & Wiring

All Zen enclosures come with six M12 rigging points on the top and four on the bottom, for simple, safe installation. Tempest offers a wide range of rigging accessories too!

And you can choose from two pairs of discreet conduit knock-outs for power and signal wiring access, on the back or top, depending on your application.

Projector Mounts

This is so important — it's easy to install your projector from either side of the Zen enclosure, and to access it the same way for service.

So, you can easily adjust the projector pan, tilt and roll, then lock it securely in position.

Professional Grade Installation

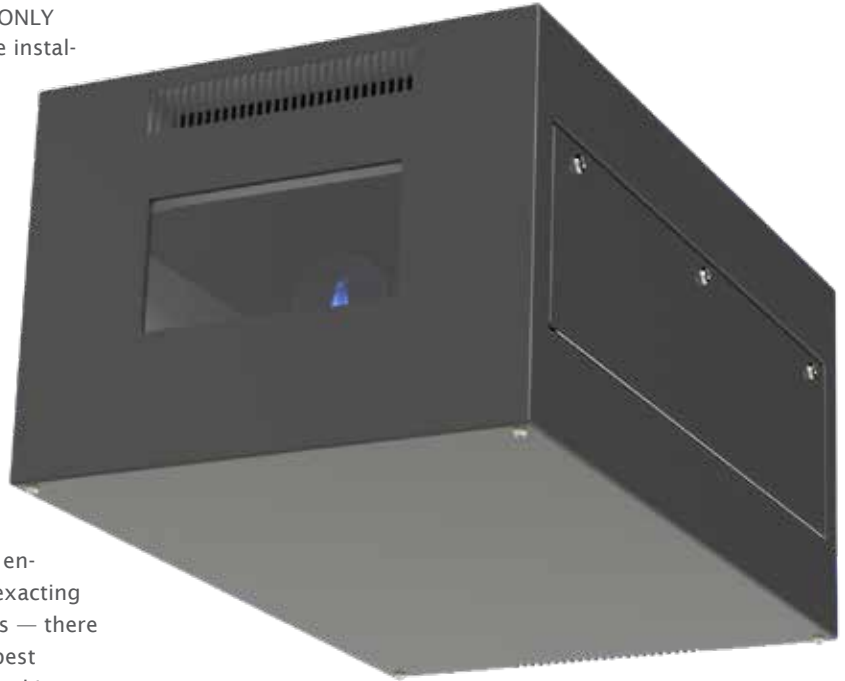

Did we mention the projector 'floats' on neoprene vibration mounts? We're not taking any chances — neither should you.

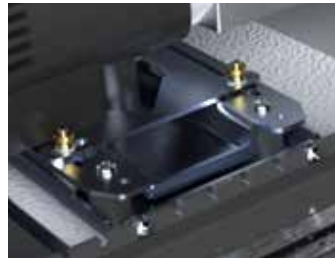

Filter

Zen's incoming air is filtered through a washable electrostatic dust filter, prolonging the life of your projector's (expensive) inlet filters.

Power Outlets

Zen gives you a dedicated projector power outlet (usually C19), as well as two C13 outlets for auxiliary equipment — media servers, fiber boxes, etc.



Port Glass

Zen's optical-grade port glass assures crisp images with minimal light loss.

Security

Three heavy-duty security latches on each side door guarantees projector security, even in public areas.

Documentation

Tempest wants you to be well-informed! Every Tempest enclosure comes with a detailed and comprehensive user manual.

And detailed acoustic data and competitive analysis is available for download at tempest.biz.

And 2D .pdf and .dwg drawings.

And 3D .STEP files.



That's Professional Grade.

Zen Hush Projector Enclosures

Zen to Go

Touring theatre, opera, dance and even orchestras are using projection more and more. So when they tour, the projectors go too.

Now Zen gives you a professional grade touring hush box, with all the benefits of the world's quietest indoor enclosure, and rigging and wiring built for the road.

Of course, you can use these rigging accessories for permanent installation too!

Truss Kit (57.TK.xxx)

Hang any Zen enclosure from any truss between 12"-24" (31-62cm).



Unistrut Kit (57.UR.xxx)

A pair of Unistrut rails mounted above or below your Zen enclosure makes installation easy, using industry-standard hardware.



Stacking Kit (51.SK)

Stack up to three Zen enclosures (ground supported) or two (hanging), with 75mm (3in) air gap between enclosures.

Professional Grade Touring



This Zen 210+ is road ready, with Truss Kit, Casters and Touring Connector options.

Casters Kit (57.CK.xxx)

Four or six heavy-duty braked casters let you roll this Zen+ off the truck, onto the stage, and fly it out (and you can travel the projector inside to save truck space).



Cyclovator (51.C2)

Adjustable tilt kit for angles up to 65° (requires Unistrut Kit).



Angle Mount Kit (55.AM.x)

Project up or down at up to 45° fixed angle with this simple kit.

Touring Connector Kit (57.TCK)

This gives you a dedicated power inlet connector plus six Neutrik feedthrough connectors on the back of the enclosure.

Power Inlets — choice of:

- Neutrik PowerCon True
- IEC309 16A
- IEC309 32A

Neutrik Feedthroughs — pick any combination of up to six compatible connectors.



That's Professional Grade.

Zen Hush Projector Enclosures

Zen — or Tacit?

Tempest also offers Tacit ducted indoor projector enclosures.

There is not much difference in noise attenuation between Tacit and Zen enclosures, but they both offer advantages for different types of application:

Use Zen:

- Simple installation
- No air ducts
- Landscape format

Use Tacit:

- Slightly better acoustic performance
- Portrait, UST versions
- Custom applications
- Hostile environments (eg: pool areas, theme park rides)
- if heat load in the space is an issue

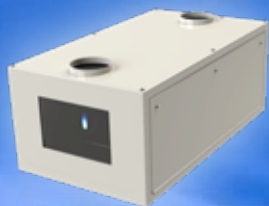

Tacit Info

Professional Grade Acoustics

Frequency (Hz)	Ambient dB	Projector (Panasonic PT-RZ21K) dB	Projector in Zen 210 Enclosure dB
20	19.4	28.2	23.3
25	17.8	29.9	34.7
32	13.6	24.7	24.7
40	17.3	24.0	26.6
50	12.2	23.2	25.4
63	16.3	26.6	28.5
80	15.0	25.1	25.2
100	7.3	28.3	25.0
125	8.0	31.6	26.5
160	1.6	34.0	28.5
200	-1.5	37.7	29.7
250	-1.2	39.0	25.3
315	-1.7	36.3	22.3
400	-1.1	35.7	19.4
500	-0.4	37.0	21.4
630	-0.1	36.2	15.5
800	0.6	35.4	11.0
1,000	1.3	35.5	10.6
1,250	1.9	34.2	8.0
1,600	3.9	31.9	6.3
2,000	3.4	29.6	5.1
2,500	4.3	31.8	5.4
3,150	5.2	29.1	5.7
4,000	6.2	23.0	6.4
5,000	7.0	19.9	7.1
6,300	7.6	17.6	7.7
8,000	7.9	14.8	7.9
10,000	8.0	13.9	8.0
12,500	8.0	12.2	8.0
16,000	8.1	13.3	8.1
20,000	8.7	21.0	8.3
dBA	17.0	44.0	26.1

Acoustic Performance Data

The data shown were generated in an anechoic chamber, using a Panasonic PT-RZ21K projector and a Zen 57.210.L enclosure. Three tests were performed:

1. Ambient chamber sound pressure level
2. Projector, 100% light output, on isolated mount
3. Projector, running in Zen enclosure, on isolated mount.

Detailed acoustic test data, from anechoic and reverberant chambers, are available for download [here](#).

Acoustic Test Setup (Anechoic Chamber)

Test Lab:

Western Electro-Acoustic Laboratory, Santa Clarita, California

Date: April 8th, 2021

Microphones:

1. 1m in front of test unit
2. 1m right of test unit
3. 1m left of test unit
4. 1m behind test unit
5. 1m below test unit

Mic values were integrated to arrive at the above values.

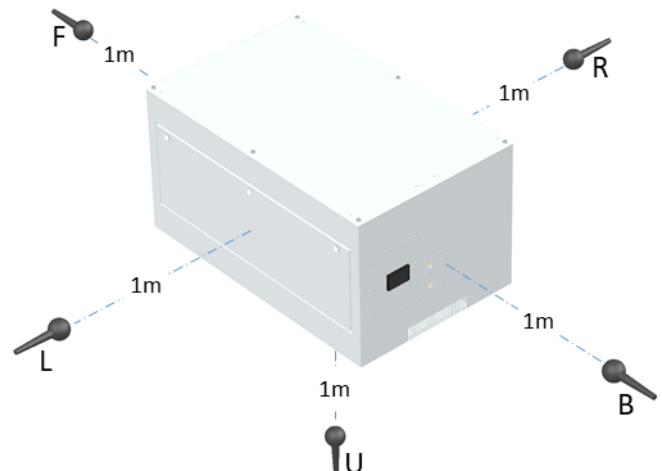

That's Professional Grade.

Zen Hush Projector Enclosures

Tempest System Manager is a Windows app running on a local PC connected to your enclosures over a local area network.

TSM discovers any Tempest enclosures present on the network at initialization, and monitors system attributes in real time, including lamp, fan and heater status, temperature, relative humidity and more.

TSM may also be used to upload firmware updates to enclosure controllers over the network, without having to visit each enclosure.

The TSM license includes 12 months unlimited user support from Tempest electronics partner JESE, and continuing support is available for a modest annual fee.

Monitoring Connections

There are two ways to connect enclosures to the TSM PC:

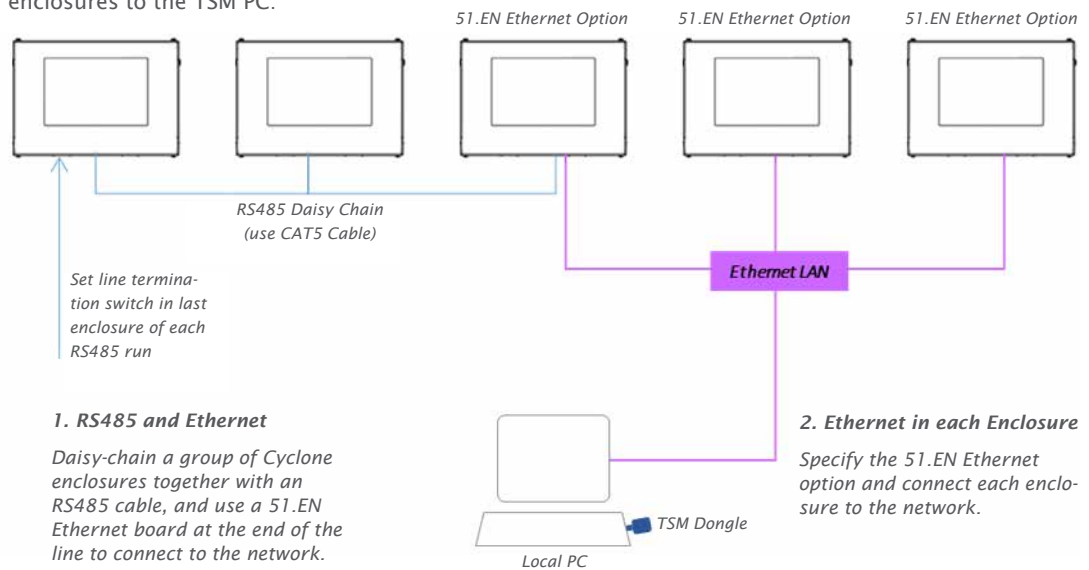

Tempest System Manager (optional with Zen+)

Index	Description	Label	Status	Voltage	Current	RH%	Temp °C	Htr %	Fan %
1	DEC4 Controller	Cyclone 310 Left 1	Lamp On	231V	12.2A	45.7%	23.4°C	0.0%	100.0%
2	DEC4 Controller	Cyclone 310 Left 2	Lamp on	231V	12.2A	46.0%	23.8°C	0.0%	100.0%
3	DEC4 Controller	Cyclone 310 Left 3	Override	231V	0.0A	49.4%	22.6°C	0.0%	0.0%
4	DEC4 Controller	Cyclone 310 Left 4	Tripped	231V	0.1A	1.2%	66.2°C	0.0%	100.0%
5	DEC4 Controller	Cyclone 310 Left 5	Lamp on	231V	12.2A	46.1%	23.4°C	0.0%	100.0%
6	DEC4 Controller	Cyclone 310 Left 6	Lamp on	231V	12.2A	46.3%	23.5°C	0.0%	100.0%
7	DEC4 Controller	Cyclone 310 Right 1	Lamp on	231V	12.2A	46.4%	23.8°C	0.0%	100.0%
8	DEC4 Controller	Cyclone 310 Right 2	Lamp on	231V	12.2A	46.3%	23.5°C	0.0%	100.0%
9	DEC4 Controller	Cyclone 310 Right 3	Lamp on	231V	12.2A	46.0%	23.2°C	0.0%	100.0%
10	DEC4 Controller	Cyclone 310 Right 4	Lamp on	231V	12.2A	46.1%	23.1°C	0.0%	100.0%
11	DEC4 Controller	Cyclone 310 Right 5	Lamp on	231V	12.2A	46.0%	23.7°C	0.0%	100.0%
12	DEC4 Controller	Cyclone 310 Right 6	Lamp on	231V	12.2A	46.2%	23.4°C	0.0%	100.0%
13	DEC4 Controller	ard 100 UST 1	Standby	231V	0.2A	51.3%	22.1°C	0.0%	0.0%
14	DEC4 Controller	ard 100 UST 2	Standby	231V	0.2A	51.8%	22.0°C	0.0%	0.0%
15	DEC4 Controller	ard 100 UST 3	Standby	231V	0.2A	51.4%	22.2°C	0.0%	0.0%
16	DEC4 Controller	ard 100 UST 4	Standby	231V	0.2A	51.3%	22.3°C	0.0%	0.0%
17	DEC4 Controller	ard 100 UST 5	Standby	231V	0.2A	51.3%	21.8°C	0.0%	0.0%
18	DEC4 Controller	ard 100 UST 6	Standby	231V	0.2A	51.6%	22.1°C	0.0%	0.0%
19	DEC4 Controller	ard 100 UST 7	Standby	231V	0.2A	51.5%	21.4°C	0.0%	0.0%
20	DEC4 Controller	Blizzard 100 UST 8	Standby	231V	0.2A	51.7%	22.2°C	0.0%	0.0%

TSM Model Numbers

- 51.TSM.10 Up to 10 enclosures
- 51.TSM.25 Up to 25 enclosures
- 51.TSM.50 Over 25 enclosures

TEMP Protocol



Tempest also publishes a simple protocol for use by integrators wishing to monitor enclosures over an existing control network.

Connection options are the same as for System Manager.

Download the TEMP Developer Guide [here](#):

Zen Models

Enclosure Dimensions

CAD Downloads: 2D DWG and PDF, 3D STEP files at www.tempest.biz

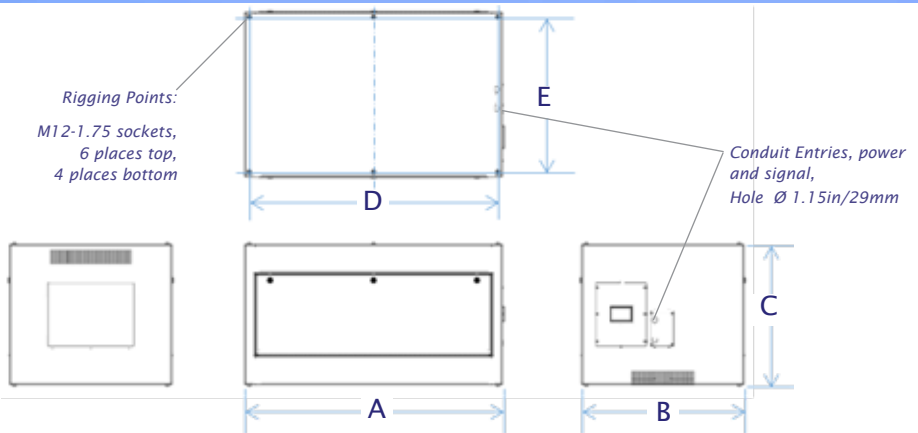

Enclosure Power

Zen models are suited to power supplies @ 90-260VAC, 50/60Hz. Max enclosure power consumption 200W. Specify line voltage when ordering

Model	Projectors	A (in/cm)	B (in/cm)	C (in/cm)	D (in/cm)	E (in/cm)	Weight
57.100.L/57.100+.L	Most @ 5-10k Lumens	40/102	32/81	24/61	38/97	30/76	89lb/40kg
57.150.L/57.150+.L	Most @ 10-15k Lumens	48/122	32/81	24/61	46/117	30/76	107lb/48kg
57.210.L/57.210+.L	Most @ 20k Lumens	54/137	34/86	29/74	52/132	32/81	154lb/70kg
57.310.L/57.310+.L	Most @ 25-30k Lumens	62/157	34/86	29/74	60/152	32/81	177lb/80kg
57.314.L/57.314+.L	Christie Griffyn	60/152	37/94	32/81	58/147	35/89	205lb/93kg
57.320.L/57.320+.L	Panasonic PT-RZ31K	70/178	37/94	32/81	68/173	35/89	240lb/109kg
57.324.L/57.324+.L	Christie D4K40-RGB	60/152	37/94	35/89	58/147	35/89	225lb/102kg
57.525.L/57.525+.L	Panasonic PT-RQ50K	70/178	37/94	37/89	68/173	35/89	462lb/119kg

Max Projector Dimensions/ Shipping Dimensions

For projectors not shown here, for portrait and UST versions, please contact Tempest.

Model	Typical Projectors	Max Length*	Max Width	Max Height	Max Power	Packed L (in/cm)	Packed W (in/cm)	Packed H (in/cm)	Packed Wt lb/kg
57.100.L	Panasonic PT-RZ120 Christie DHD-1075-HS Epson L1700 DPI E-Vision Laser10K	27/69	26/66	11/28	1250W	48/122	40/102	36/91	179/81
57.150.L	Barco F80, F90 Christie HS (16K)	35/89	26/66	11/28	1500W	S H I P P I N G	40/102	34/86	197/89
57.210.L	Barco UDM Christie HS (20K) Panasonic PT-RZ12 Panasonic PT-RZ21K Panasonic PT-RQ35K	41/104	28/71	16/41	2500W		42/107	39/99	274/125
57.310.L	Barco UDX, Christie Boxer/Crimson	49/126	28/71	16/41	3500W		42/107	39/99	317/144
57.314.L	Christie Griffyn	47/120	31/79	19/48	3500W		45/114	42/107	345/157
57.320.L	Panasonic PT-RZ31K	57/145	31/79	19/48	4000W		45/114	42/107	390/177
57.324.L	Christie D4K40-RGB	47/120	31/79	22/56	4000W		45/114	45/114	395/179
57.525.L	Panasonic PT-RQ50K	57/145	31/79	22/56	4000W		45/114	45/114	432/196

* Max length including lens, cables, connectors

All Schedule B Export Code: 9405.99.0000

Custom Colors

All the enclosures in this brochure are shown in our standard warm white semi-gloss finish or black. Any RAL color available to special order.

Options

- + Insert '+' after the model number for Zen Plus, eg: 57.210+.L
- 51.EN Ethernet Comms
- 51.TSM.xx Tempest System Manager
- 57.815 Replacement Inlet Filter for Zen enclosures manufactured after 2020
- 0000.CL Custom Color — specify any RAL #, plus % gloss desired

- 57.UR.xxx Unistrut Rail Kit (Use the 3-digit enclosure model #, eg 57.UR.210 for Zen 57.210)
- 55.AM.x Angle Mount Kit
- 57.TK.xxx Zen Truss Kit (Use the 3-digit enclosure model #, eg 57.TK.210 for Zen 57.210)
- 51.SK Stacking Kit
- 51.C2 Cyclovator

Zen Configurator

Please complete this form and email to us at info@tempest.biz

Name		
Company		
Email		
Phone		
Projector & Lens Make & Model	Projector:	Lens:
Zen Model	57. _____	Zen+? Yes <input type="checkbox"/> No <input type="checkbox"/>
Quantity		
Destination Country		
Install Date		
Supply Voltage	100-120VAC <input type="checkbox"/> 200-208VAC <input type="checkbox"/> 220-240VAC <input type="checkbox"/>	
Unistrut Kit	Yes, Qty _____ Top <input type="checkbox"/> Bottom <input type="checkbox"/> No <input type="checkbox"/>	
Stacking Kit	Yes, Qty _____ No <input type="checkbox"/>	
Truss Kit	Yes, Qty _____ No <input type="checkbox"/>	
Angle Mount	Yes, Qty _____ No <input type="checkbox"/>	
Cyclovator	Yes, Qty _____ No <input type="checkbox"/>	
Ethernet Option	Yes, Qty _____ No <input type="checkbox"/>	
Spare Inlet Filter	Yes, Qty _____ No <input type="checkbox"/>	
Color	Standard, Warm White <input type="checkbox"/> Standard, Black <input type="checkbox"/> Custom, RAL # _____ Gloss Level * _____% * Gloss levels higher than 30% may show up weld marks. Tempest advises against high gloss finishes and accepts no liability in this event.	

Custom Requests:

Factory Use Only:	
SO Number	
Date	
Electrical	IEC <input type="checkbox"/> NEMA <input type="checkbox"/>



User manuals,
2D and 3D CAD
drawings at
www.tempest.biz