



TEMPEST

Tornado

Moving Light
Enclosures



Tornado

Moving Light Enclosures

Tempest, the world's leading manufacturer of specialist lighting and projector enclosures, brings you Tornado, simply the best lighting enclosures in the world to protect valuable automated luminaires from any weather, in any climate.

The evolution of twenty years experience protecting lights in all climates around the world, today's Tornado brings you:

- DEC4 control, with a choice of RS485 (RDM) or Ethernet monitoring — with web-based monitoring coming soon.
- Powerful fans change the air every 1-2 seconds in the enclosure when the luminaire is on, maintaining a cool operating environment and optimizing equipment and lamp life.
- Aluminum, stainless steel and acrylic construction for excellent corrosion resistance in any climate.
- More sizes, tailored for the latest generation of high-efficiency moving lights.

Thousands of Tornado enclosures are in daily use in every climate type there is, from the frozen North to the tropics and deserts, in theme parks, resorts, attractions and cruise ships.

Tornado is our finest general purpose lighting enclosure family yet, building on an unmatched experience base, and offering you the best protection in the world for your lighting investment.

For salt fog environments on ships and beach locations, check out our **Tornado Marine** catalog.



Our biggest Tornado ever — Tornado 2500, shown here with a Syncrolite SyncroMITE Beam



Tornado 1925V, base up, globe down, for Super Sharpy and similar luminaires

Tornado

Moving Light Enclosures

Tornado

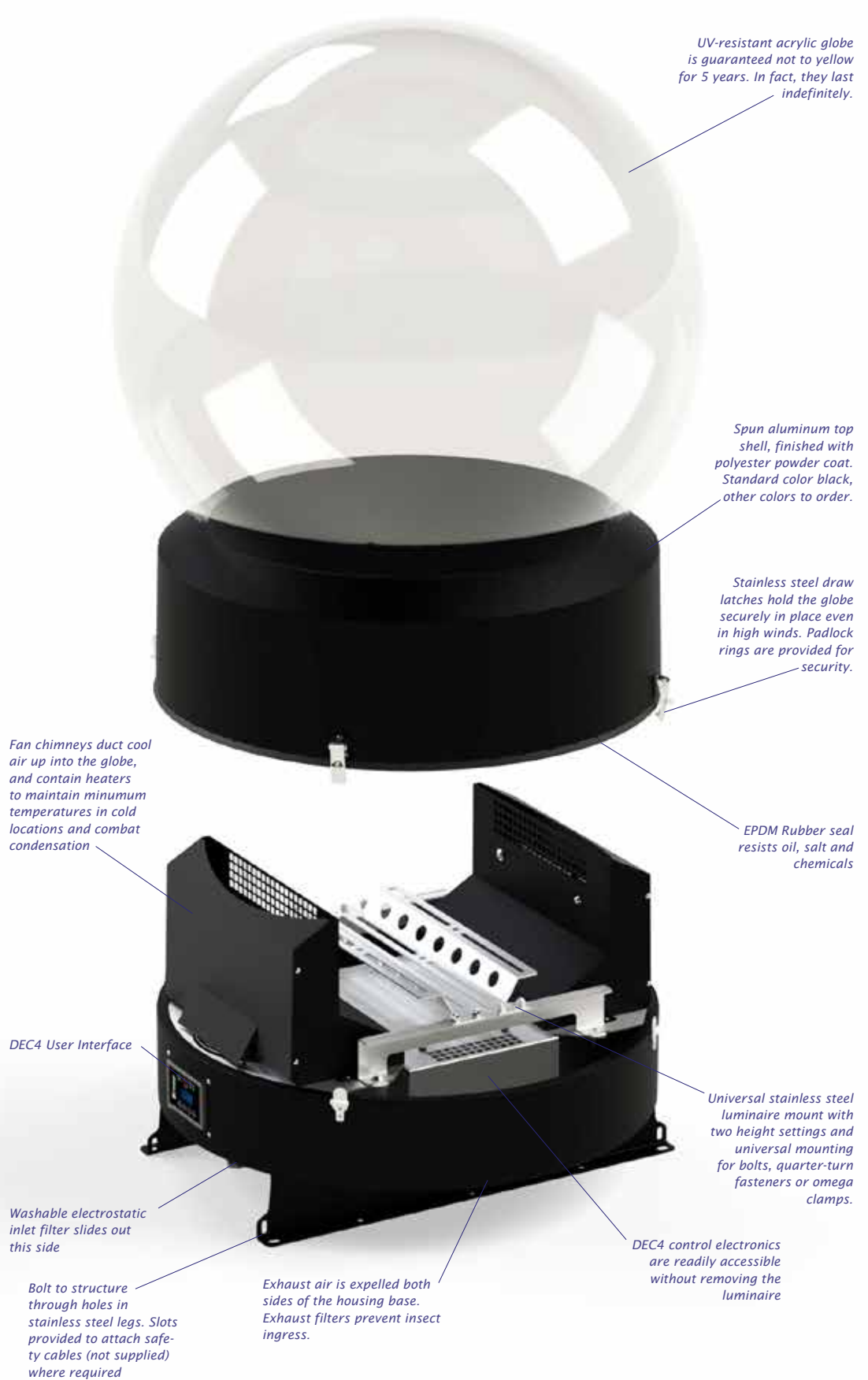

Tornado

Moving Light Enclosures

Which Tornado?

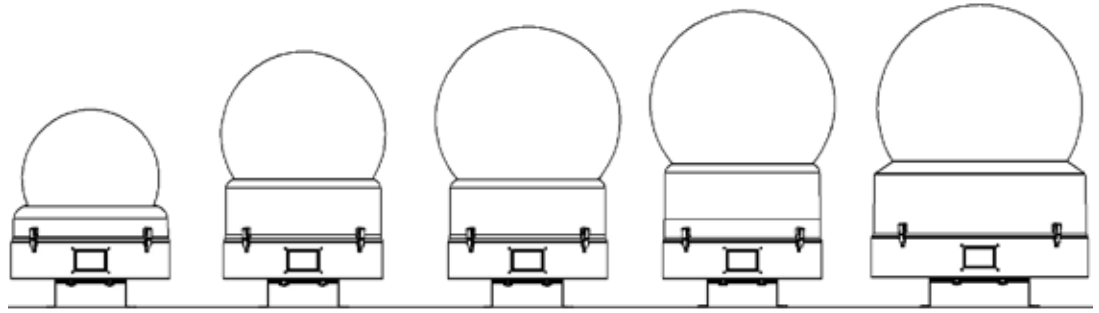

Tornado 1850

Luminaire max:
A: 16.5"/420mm
B: 16"/410mm
Watts: 500
Globe Ø: 20"/510mm

Tornado 1900

Luminaire max:
A: 24.5"/620mm
B: 16"/410mm
Watts: 600
Globe Ø: 24"/610mm

Tornado 1925/35

Luminaire max:
A: 28"/710mm
B: 16"/410mm
Watts: 1925: 600
1935: 800
Globe Ø: 27"/686mm

Tornado 1975

Luminaire max:
A: 30.5"/775mm
B: 16"/410mm
Watts: 600
Globe Ø: 27"/686mm

Tornado 2000

Luminaire max:
A: 30.5"/775mm
B: 24"/610mm
Watts: 1,200
Globe Ø: 30"/762mm

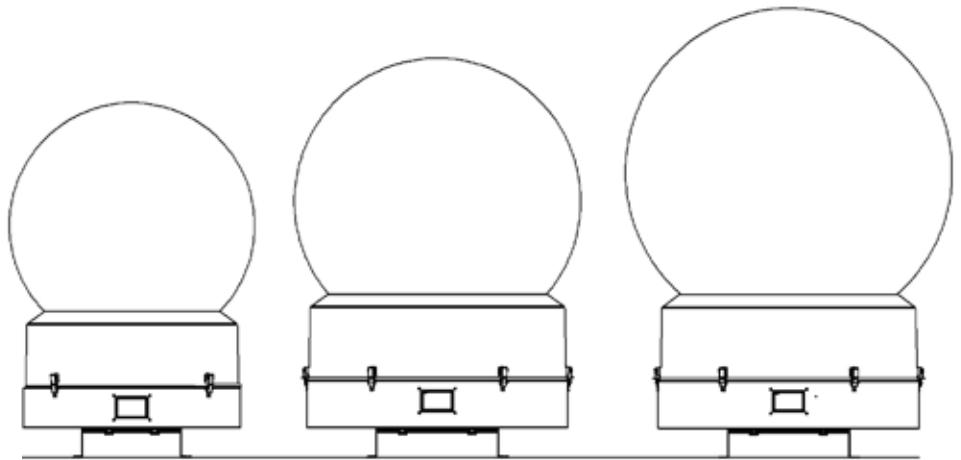

Tornado 2300/2360*

Luminaire max:
A: 38"/970mm
B: 24"/610mm
Watts: 1,700
Globe Ø: 36"/915mm

Tornado 2400

Luminaire max:
A: 44"/1,115mm
B: 28"/710mm
Watts: 2,500
Globe Ø: 42"/1,067mm

Tornado 2500

Luminaire max:
A: 52"/1,320mm
B: 28"/710mm
Watts: 3,000
Globe Ø: 48"/1,219mm

*** NEW!**

Tornado 2360,
just for Vari*Lite
VL6000
Beam



Notes:

- Luminaire Max Watts means total power consumption, not lamp wattage
- LED luminaires with multiple LED circuits — it is ok to exceed max watts if luminaires will rarely be used in white

- Luminaire Max Height assumes luminaire mounting in low fixture beam setting, using omega clamps. For maximum luminaire height, omit omegas and mount directly to luminaire base (see manual)

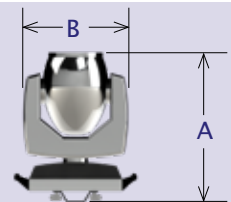

Globe Up

(Standard Configuration)



Globe Down

Add V to model number

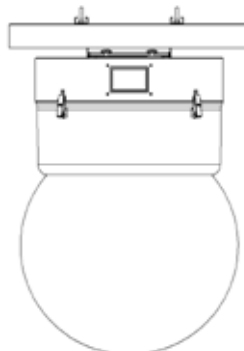

Horizontal (Models 1850-2500)

Add H to model number

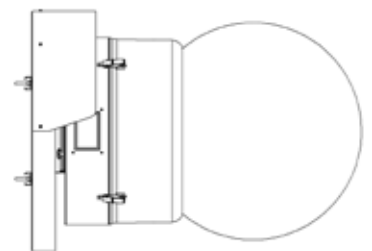

Yeosu, Korea — the 2012 Maritime World Fair. The Big O, constructed on a man-made island in Yeosu harbor, is 50m in diameter, and houses 48 Martin MAC2K luminaires, in Tornado enclosures. There are another 32 Tornados around the base and on shore, with MAC3 luminaires.

Now the bad news — between each light on the Big O is an automated water jet — like a programmable fire hose creating an amazing water ballet. Oh yes, and it's SALT water, pumped right out of the harbor!

So, since 2012 these lights have been running every night in a kind of saltwater Niagara Falls — probably the worst environment you could imagine.

The good news?

No problems.



Big O:
Design by ECA2, Paris
Integration By Hansam Systems, Seoul

Watch the video at
tempest.biz/installations



Tornado

Moving Light Enclosures

RS485 Comms (standard)

Daisy-chain a group of Tornado enclosures together with this RS485 board — one per enclosure, and monitor using a JESE RDM-TXI interface (Tempest part # 2000.195).

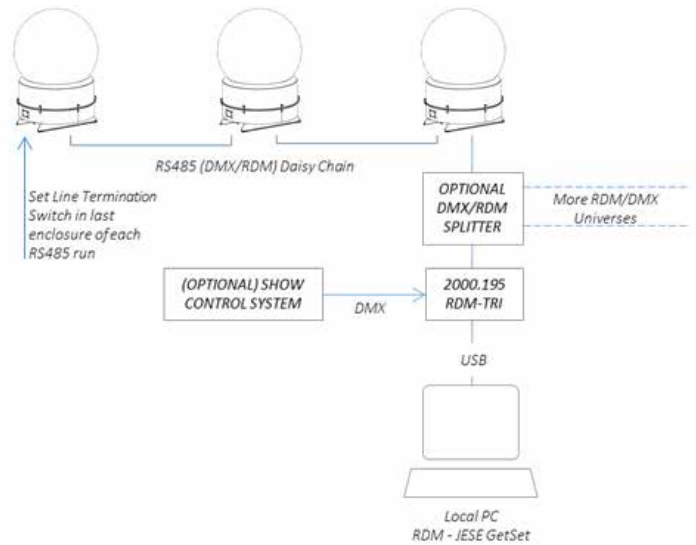

51.EN Ethernet Comms

Use this Ethernet adapter to connect one Tornado or a group of Tornados connected using RS485 to a PC or show control system, and monitor using Tempest TEMP protocol. Download the TEMP Developer Guide from www.tempest.biz/tech-support.

Goldilocks™

How do we keep your lights from roasting when it's 50°C and there's no shade?

And prevent condensation from destroying your projector overnight?

Tempest's unique Goldilocks™ Operating System (patents pending) brings enclosure control to a new level.

Goldilocks keeps the air temperature inside your enclosure just right, removing heat from the projector when the lamp is on or when the enclosure is heated by the sun. We're changing the air every few seconds.

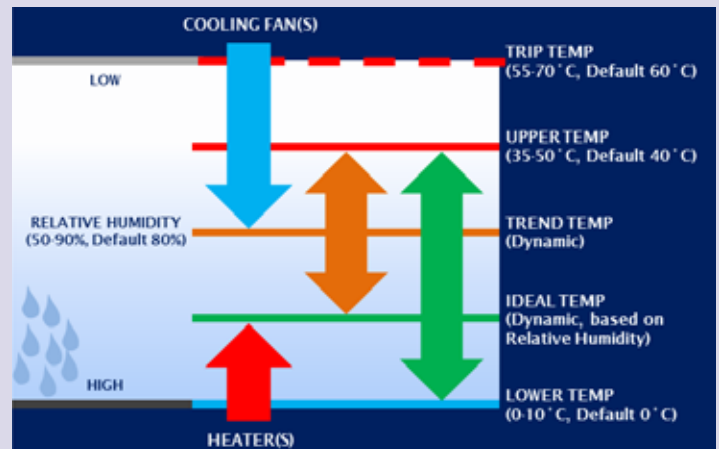

Goldilocks uses a heater to maintain a minimum temperature in cold climates.

And Goldilocks tracks temperature and humidity 24/7, keeping relative humidity inside your

enclosure just right by using heaters to raise the air temperature when needed, adapting constantly to prevent deadly condensation.

Ordering Guide - International

Part #	Description	Globe ↑↓	Volts 50/60Hz	Globe Ø in [cm]	Height in [cm]	Weight lbs [kg]	Light Max A in [cm]	Light Max B in [cm]	Light Max Watts	Shipping ** Dimensions (lwh) in [cm]	Packed Weight lbs [kg]
1850.ING	Tornado 1850, Globe Up	↑	200-250	20 [51]	32 [82]	42 [19]	16.5[42]	16 [41]	500	32x32x46	67 [30]
1850.INGV	Tornado 1850, Globe Down	↓	200-250	20 [51]	32 [82]	45 [21]	16.5[42]	16 [41]	500	[81x81x102]	70 [32]
1850.INGH	Tornado 1850, Horizontal	→	200-250	20 [51]	32 [82]	46 [21]	16.5[42]	16 [41]	500	"	70 [32]
1900.ING	Tornado 1900, Globe Up	↑	200-250	24 [61]	38 [98]	52 [24]	24.5 [62]	16 [41]	500	"	75 [34]
1900.INGV	Tornado 1900, Globe Down	↓	200-250	24 [61]	39 [99]	60 [27]	24.5 [62]	16 [41]	500	"	83 [38]
1900.INGH	Tornado 1900, Horizontal	→	200-250	24 [61]	39 [99]	60 [27]	24.5 [62]	16 [41]	500	"	83 [38]
1925.ING	Tornado 1925, Globe Up	↑	200-250	27 [69]	42 [107]	54 [25]	28[71]	16 [41]	600	"	77 [35]
1925.INGV	Tornado 1925, Globe Down	↓	200-250	27 [69]	43 [109]	62 [28]	28[71]	16 [41]	600	"	91 [41]
1925.INGH	Tornado 1925, Horizontal	→	200-250	27 [69]	43 [109]	62 [28]	28[71]	16 [41]	600	"	91 [41]
1935.ING	Tornado 1935, Globe Up	↑	200-250	27 [69]	42 [107]	54 [25]	28[71]	16 [41]	800	"	77 [35]
1935.INGV	Tornado 1935, Globe Down	↓	200-250	27 [69]	42 [107]	62 [28]	28[71]	16 [41]	800	"	91 [41]
1935.INGH	Tornado 1935, Horizontal	↑	200-250	27 [69]	42 [107]	62 [28]	28[71]	16 [41]	800	"	91 [41]
1975.ING	Tornado 1975, Globe Up	↑	200-250	27 [69]	45 [115]	57 [26]	30.5 [78]	16 [41]	600	32x32x48	80 [36]
1975.INGV	Tornado 1975, Globe Down	↓	200-250	27 [69]	46 [117]	65 [30]	30.5 [78]	16 [41]	600	[81x81x122]	90 [41]
1975.INGH	Tornado 1975, Horizontal	→	200-250	27 [69]	45 [115]	57 [26]	30.5 [78]	16 [41]	600	"	80 [36]
2000.ING	Tornado 2000, Globe Up	↑	200-250	30 [76]	45 [115]	110 [50]	30.5 [78]	21 [53]	1200	39x39x54	145 [66]
2000.INGV	Tornado 2000, Globe Down	↓	200-250	30 [76]	46 [117]	115[55]	30.5 [78]	21 [53]	1200	[100x100x137]	160 [73]
2000.INGH	Tornado 2000, Horizontal	→	200-250	30 [76]	46 [117]	120 [55]	30.5 [78]	21 [53]	1200	"	165 [75]
2300.ING	Tornado 2300, Globe Up	↑	200-250	36 [91]	53 [135]	111 [51]	38 [97]	21 [53]	1,700	"	145 [66]
2300.INGV	Tornado 2300, Globe Down	↓	200-250	36 [91]	54 [137]	126 [57]	38 [97]	21 [53]	1,700	"	160 [73]
2300.INGH	Tornado 2300, Horizontal	→	200-250	36 [91]	53 [135]	130 [59]	38 [97]	21 [53]	1,700	"	165 [75]
2360.ING	Tornado 2360, Globe Up	↑	200-250	36 [91]	53 [135]	111 [51]		VL6000		"	145 [66]
2360.INGV	Tornado 2360, Globe Down	↓	200-250	36 [91]	54 [137]	126 [57]		VL6000		"	160 [73]
2360.INGH	Tornado 2360, Horizontal	→	200-250	36 [91]	53 [135]	130 [59]		VL6000		"	165 [75]
2400.ING	Tornado 2400, Globe Up	↑	200-250	42 [107]	61 [153]	204 [93]	44 [112]	28 [71]	2,500	48x48x69	245 [111]
2400.INGV	Tornado 2400, Globe Down	↓	200-250	42 [107]	61 [153]	209 [95]	44 [112]	28 [71]	2,500	[122x122x175]	250 [114]
2500.ING	Tornado 2500, Globe Up	↑	200-250	48 [122]	67 [170]	192 [87]	52 [132]	28 [71]	3,000	54x54x75	260 [118]
2500.INGV	Tornado 2500, Globe Down	↓	200-250	48 [122]	68 [172]	212 [96]	52 [132]	28 [71]	3,000	[137x137x191]	270 [123]

Options

51.EN	Ethernet Board (Links an enclosure or a group of enclosures with RS485 boards to an Ethernet network, for use with TEMP protocol)
51.DF.23	Spare Electrostatic Foam Inlet Filter, Tornado 1850-1975
51.DF.32	Spare Electrostatic Foam Inlet Filter, Tornado 2000-2300
51.DF.38	Spare Electrostatic Foam Inlet Filter, Tornado 2400-2300
0000.CL	Custom Base Color (standard is Black). Specify White or any RAL number

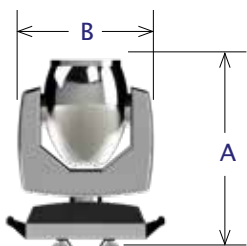

** All Schedule B Export Code: 9405.99.0000

All Tornado Enclosures are built to order. Please consult factory for lead times.

All sales are subject to Tempest Lighting, Inc. Standard Terms and Conditions, available for download at www.tempest.biz.

Custom Colors

All the enclosures in this brochure are shown in Tornado standard Black (Semi-matt, light texture) finish. White or any RAL color are available to special order.



CAD drawings and user manuals at www.tempest.biz

Ordering Guide - North America & Japan

Part #	Description	Globe ↑↓	Volts 50/60Hz	Globe Ø US [cm]	Height US [cm]	Weight lbs [kg]	Light Max A US [cm]	Light Max B US [cm]	Light Max Watts	Shipping ** Dimensions (lwh) in [cm]	Packed Weight lbs [kg]
1850.USG	Tornado 1850, Globe Up	↑	200-250*	20 [51]	32 [82]	42 [19]	16.5[42]	16 [41]	500	32x32x46	67 [30]
1850.USGV	Tornado 1850, Globe Down	↓	200-250*	20 [51]	32 [82]	45 [21]	16.5[42]	16 [41]	500	[81x81x102]	70 [32]
1850.USGH	Tornado 1850, Horizontal	→	200-250*	20 [51]	32 [82]	46 [21]	16.5[42]	16 [41]	500	"	70 [32]
1900.USG	Tornado 1900, Globe Up	↑	200-250*	24 [61]	38 [98]	52 [24]	24.5 [62]	16 [41]	500	"	75 [34]
1900.USGV	Tornado 1900, Globe Down	↓	200-250*	24 [61]	39 [99]	60 [27]	24.5 [62]	16 [41]	500	"	83 [38]
1900.USGH	Tornado 1900, Horizontal	→	200-250*	24 [61]	39 [99]	60 [27]	24.5 [62]	16 [41]	500	"	83 [38]
1925.USG	Tornado 1925, Globe Up	↑	200-250*	27 [69]	42 [107]	54 [25]	28[71]	16 [41]	600	"	77 [35]
1925.USGV	Tornado 1925, Globe Down	↓	200-250*	27 [69]	43 [109]	62 [28]	28[71]	16 [41]	600	"	91 [41]
1925.USGH	Tornado 1925, Horizontal	→	200-250*	27 [69]	43 [109]	62 [28]	28[71]	16 [41]	600	"	91 [41]
1935.USG	Tornado 1935, Globe Up	↑	200-250*	27 [69]	43 [109]	54 [25]	28[71]	16 [41]	800	"	77 [35]
1935.USGV	Tornado 1935, Globe Down	↓	200-250*	27 [69]	43 [109]	62 [28]	28[71]	16 [41]	800	"	91 [41]
1935.USGH	Tornado 1935, Horizontal	→	200-250*	27 [69]	43 [109]	62 [28]	28[71]	16 [41]	800	"	91 [41]
1975.USG	Tornado 1975, Globe Up	↑	200-250*	27 [69]	45 [115]	57 [26]	30.5 [78]	16 [41]	600	32x32x48	80 [36]
1975.USGV	Tornado 1975, Globe Down	↓	200-250*	27 [69]	46 [117]	65 [30]	30.5 [78]	16 [41]	600	[81x81x122]	90 [41]
1975.USGH	Tornado 1975, Horizontal	→	200-250*	27 [69]	45 [115]	57 [26]	30.5 [78]	16 [41]	600	"	80 [36]
2000.USG	Tornado 2000, Globe Up	↑	200-250*	30 [76]	45 [115]	110 [50]	30.5 [78]	21 [53]	1200	39x39x54	145 [66]
2000.USGV	Tornado 2000, Globe Down	↓	200-250*	30 [76]	46 [117]	115[55]	30.5 [78]	21 [53]	1200	[100x100x137]	160 [73]
2000.USGH	Tornado 2000, Horizontal	→	200-250*	30 [76]	46 [117]	120 [55]	30.5 [78]	21 [53]	1200	"	165 [75]
2300.USG	Tornado 2300, Globe Up	↑	200-250*	36 [91]	53 [135]	111 [51]	38 [97]	21 [53]	1,700	"	145 [66]
2300.USGV	Tornado 2300, Globe Down	↓	200-250*	36 [91]	54 [137]	126 [57]	38 [97]	21 [53]	1,700	"	160 [73]
2300.USGH	Tornado 2300, Horizontal	→	200-250*	36 [91]	53 [135]	130 [59]	38 [97]	21 [53]	1,700	"	165 [75]
2360.USG	Tornado 2360, Globe Up	↑	200-250	36 [91]	53 [135]	111 [51]		VL6000		"	145 [66]
2360.USV	Tornado 2360, Globe Down	↓	200-250	36 [91]	54 [137]	126 [57]		VL6000		"	160 [73]
2360.USH	Tornado 2360, Horizontal	→	200-250	36 [91]	53 [135]	130 [59]		VL6000		"	165 [75]
2400.USG	Tornado 2400, Globe Up	↑	200-250	42 [107]	61 [153]	204 [93]	44 [112]	28 [71]	2,500	48x48x69	245 [111]
2400.USGV	Tornado 2400, Globe Down	↓	200-250	42 [107]	61 [153]	209 [95]	44 [112]	28 [71]	2,500	[122x122x175]	250 [114]
2500.USG	Tornado 2500, Globe Up	↑	200-250	48 [122]	67 [170]	192 [87]	52 [132]	28 [71]	3,000	54x54x75	260 [118]
2500.USGV	Tornado 2500, Globe Down	↓	200-250	48 [122]	68 [172]	212 [96]	52 [132]	28 [71]	3,000	[137x137x191]	270 [123]

Options

51.EN	Ethernet Board (Links an enclosure or a group of enclosures with RS485 boards to an Ethernet network, for use with TEMP protocol)
20.SWR	Stainless Steel Safety Wire ring on Globe Assembly (safety wire not included)
51.DF.23	Spare Electrostatic Foam Inlet Filter, Tornado 1850-1975
51.DF.32	Spare Electrostatic Foam Inlet Filter, Tornado 2000-2500
51.DF.38	Spare Electrostatic Foam Inlet Filter, Tornado 2400-2500
0000.CL	Custom Base Color (standard is Black). Specify White or any RAL number

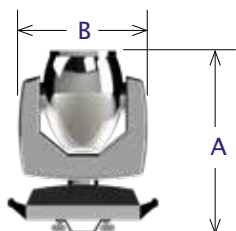

* May be supplied 120V to special order

** All Schedule B Export Code: 9405.99.0000

All Tornado Enclosures are built to order. Please consult factory for lead times.

All sales are subject to Tempest Lighting, Inc. Standard Terms and Conditions, available for download at www.tempest.biz.

Custom Colors

All the enclosures in this brochure are shown in Tornado standard Black (Semi-matt, light texture) finish. White or any RAL color are available to special order.



Tornado Configurator

Please complete this form and email to us at info@tempest.biz

Name	
Company	
Email	
Phone	
Project Name and Location	
Luminaire type	
Tornado Model	
Quantity	
Destination Country	
Install Date	
Orientation	Globe Up <input type="checkbox"/> Globe Down <input type="checkbox"/> Horizontal <input type="checkbox"/>
Required Options	
51.EN Ethernet Board	Yes, Qty _____ No <input type="checkbox"/>
20.SWR Safety Wire Ring	Yes, Qty _____ No <input type="checkbox"/>
Spare Inlet Filter	Yes, Qty _____ No <input type="checkbox"/>
Color	Standard, Black <input type="checkbox"/>
	Custom, RAL # _____
	Gloss Level _____%
Factory Use Only:	
SO Number	
Date	
Electrical	IEC <input type="checkbox"/> NEMA <input type="checkbox"/>

Custom Requests:



Tornado 2300, for most popular 1200-1700W Luminaires

 Made in the USA
 ©Tempest Lighting, Inc., February 2021
 In the interest of continuous product improvement, specifications are subject to change without notice

Tempest Lighting, Inc.,
 11845 Wicks Street, Sun Valley, CA 91352, USA
www.tempest.biz info@tempest.biz
 t: +1 818 787 8984 f: +1 818 252 7101