

AC Assist Spot Cooler

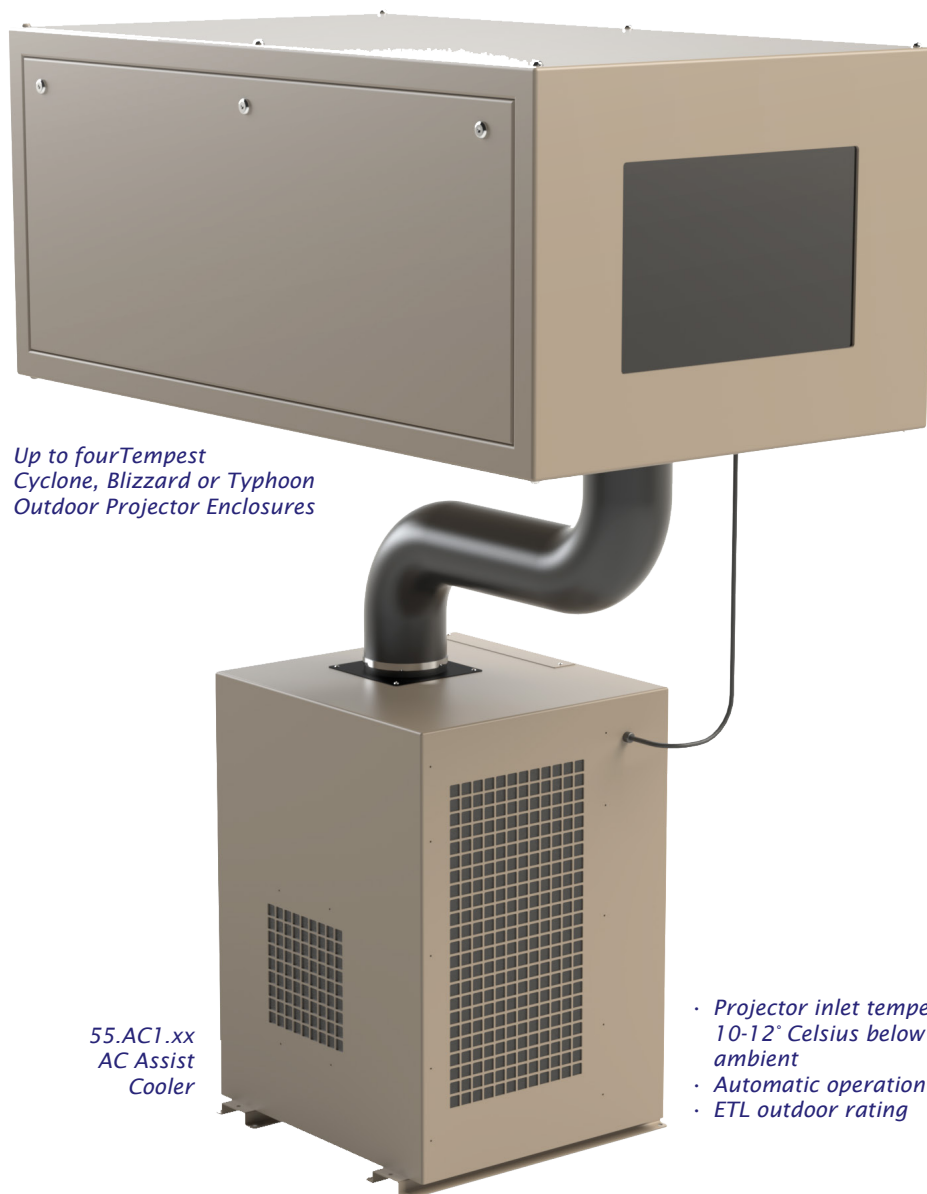

*Up to four Tempest
Cyclone, Blizzard or Typhoon
Outdoor Projector Enclosures*

*55.AC1.xx
AC Assist
Cooler*

- Projector inlet temperature
10-12° Celsius below
ambient*
- Automatic operation*
- ETL outdoor rating*

Now you can run your projector cool in even the most extreme outdoor temperatures. Tempest AC Assist blends cooled air with filtered outside air to deliver operating temperatures within limits for even the most sensitive laser projectors, in the hottest parts of the world.

Tempest Cyclone and Blizzard enclosures have been protecting sensitive equipment for years, in the most extreme climates, and in most cases the standard enclosure does a fine job. But there are times — and places — where the only way to keep a projector within its operating limits is to cool the air it breathes. The new generation of laser projectors may also need lower ambient temperatures to achieve maximum life and/or brightness.

The active cooling unit is housed in a separate ETL-listed outdoor-rated enclosure, eliminating compressor vibration.

Tempest AC Assist blends cooled air through the enclosure inlet filter, only when the projector lamp is on.

Tempest AC Assist reduces projector inlet temperature 10-12°C, assuring optimal operating conditions in even the hottest locations. Each AC Assist unit may cool up to four enclosures, depending on the heat load of the projectors used.

Ordering Guide

Part #	Supply Voltage	# of Air Hoses	Projector BTU	
55.AC1.IN	200-240VAC, 50Hz	1	up to 24,000	<i>Note: 55.ACx.xx part number includes cooler, flexible air hose(s), control and power connector, as well as control installed in the controlling enclosure.</i>
55.AC1.US	100-120VAC, 60Hz	1	up to 24,000	
55.AC2.IN	200-240VAC, 50Hz	2	up to 12,000	
55.AC2.US	100-120VAC, 60Hz	2	up to 12,000	
55.AC3.IN	200-240VAC, 50Hz	3	up to 8,000	
55.AC3.US	100-120VAC, 60Hz	3	up to 8,000	
55.AC4.IN	200-240VAC, 50Hz	4	up to 6,000	
55.AC4.US	100-120VAC, 60Hz	4	up to 6,000	

AC55.VM

Anti-Vibration Mounting Kit. Recommended when the AC Assist cooler and projector enclosure are mounted on the same concrete pad or structural frame, especially in long-throw applications.

Specification

Cooling Capacity: 14,000btu/hr*

Refrigerant: R-410A

Electrical:

55.ACx.IN 200-250VAC
3,000W
50Hz

Weight: 250lb/114kg

55.ACx.US 100-125VAC
3,000W
60Hz

Weight: 220lb/100kg

Hose:

Insulated, flexible, 150mm (6") ID

Max length: 4m (13')

Compliance: ETL, CE

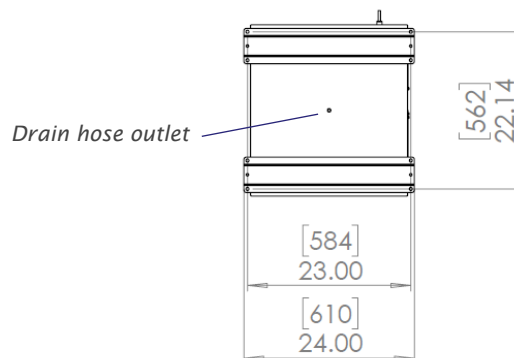
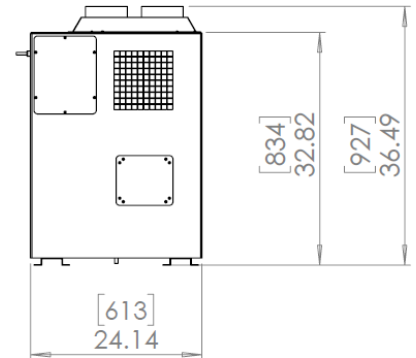
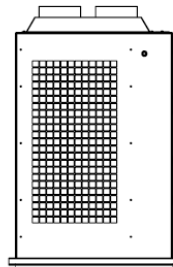
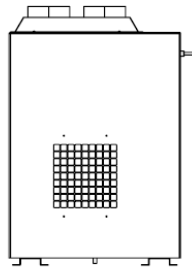
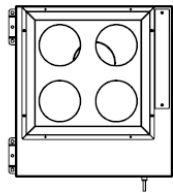
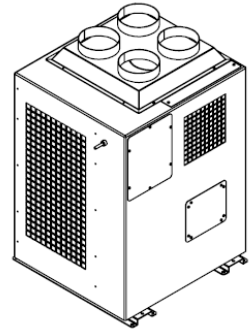

55.AC4 shown here.
All versions same dimensions

Made in the USA

©Tempest Lighting, Inc., January 2020

In the interest of continuous product improvement, specifications are subject to change without notice

Tempest Lighting, Inc

11845 Wicks Street, Sun Valley, CA 91352, USA

www.tempest.biz info@tempest.biz

t: +1 818 787 8984 f: +1 818 982 5510

