

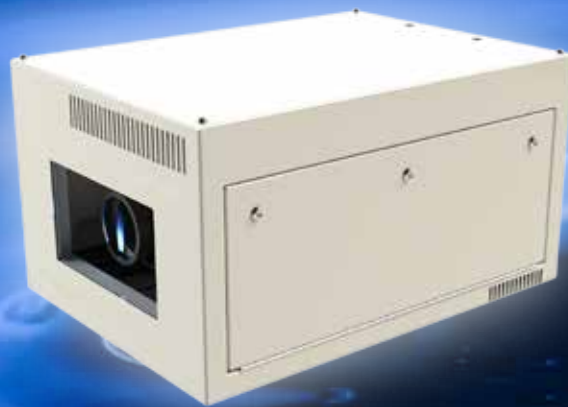

TEMPEST

Zen  
Hush  
Projector  
Enclosures  
10-40K



**G** Fourth  
Generation  
Projector  
Enclosures

# Zen Hush Projector Enclosures

Tempest is the world's leading manufacturer of large format indoor projector enclosures for noise attenuation in presentation suites, digital cinema, live theatre and concert venues — any noise-sensitive indoor space.

Until now, Tempest's Whisper and Tacit enclosures achieved excellent noise attenuation through the use of cooling fans located in a remote location, so that their noise is not disturbing to the audience.

## Integral Cooling

Inlet air enters through the base, through an inlet labyrinth made from fire-resistant melamine acoustic foam. It then passes through an electrostatic dust filter before reaching the projector.

Air exhaust is similarly wound through an exhaust labyrinth above the projector chamber and exhausted above the enclosure port glass.

perature inside the enclosure. So you can tune the system yourself for the optimal tradeoff between running temperature and noise attenuation.

## Projector Access

Zen offers excellent projector access, with opening side doors, allowing the projector to slide smoothly out of the enclosure for routine maintenance. Specify left or right slide when ordering.

Standard color: White (RAL 9003). Black and custom colors to order.

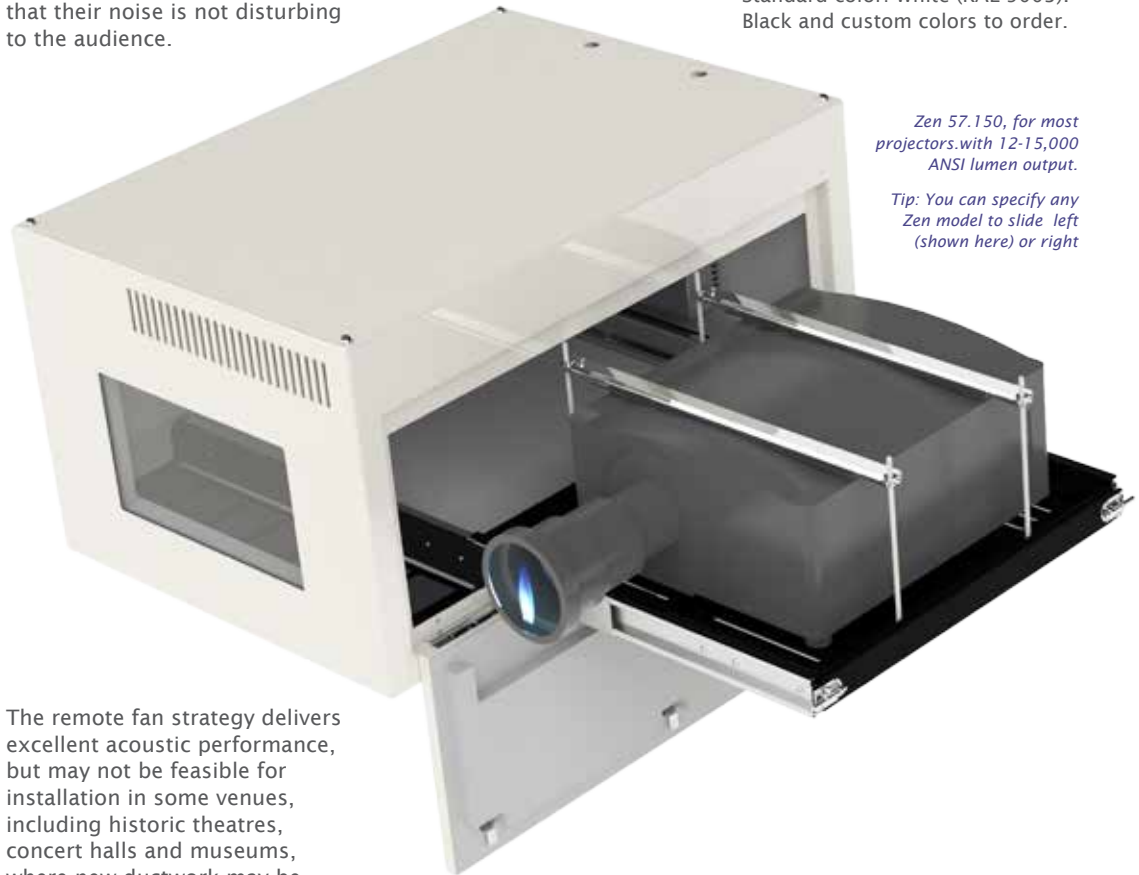

*Zen 57.150, for most projectors with 12-15,000 ANSI lumen output.*

*Tip: You can specify any Zen model to slide left (shown here) or right*

The remote fan strategy delivers excellent acoustic performance, but may not be feasible for installation in some venues, including historic theatres, concert halls and museums, where new ductwork may be prohibited.

Now, Tempest Zen enclosures offer a standalone solution, with noise attenuation close to remote fan levels, but without the need for inlet or exhaust ducts.

## Variable-Speed DC Fans

Zen enclosures use overdimensioned thermostatically controlled DC fans, running as slowly (and quietly) as possible, consistent with maintaining a user-set maximum tem-

Zen is equipped with Tempest's patented DEC4 Digital Enclosure Control system, featuring a comprehensive display and remote monitoring options.

zen : a state of calm attentiveness in which one's actions are guided by intuition rather than by conscious effort.

Webster's Dictionary

## Integral Cooling

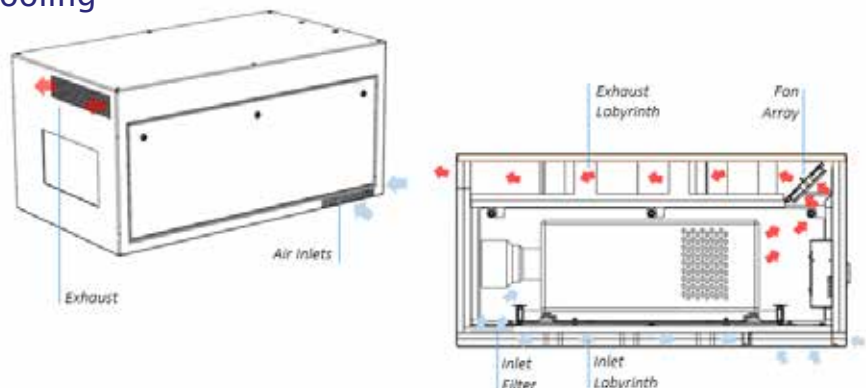

# Zen Hush Projector Enclosures

## Variable Speed Fan Control

Zen enclosures use powerful DC fans, thermostatically controlled to maintain a user-set maximum internal temperature. Since the fans used are significantly over-dimensioned, it follows that they can run very slowly — and quietly — to keep the projector cool. This means longer fan and filter life, and quietest possible operation.

The user can adjust the target temperature to achieve a pre-determined tradeoff between temperature and noise level tailored to the needs of every installation.

## Individual Fan Monitoring

Zen enclosures can also tell you how each fan in a whole installation is performing. DEC4 compares calculated and actual

fan speed, and is able to alert you if one of the fans in a system needs attention.

Combined with the JESE Agent remote monitoring service this means you could be receiving an email telling you it's time to check the third fan on enclosure two!

## Zen System Monitoring

### RS485 Comms (standard)

Daisy-chain a group of Cyclone enclosures together with this RS485 board — one per enclosure, and monitor using a JESE RDM-TXI interface (Tempest part # 2000.195).

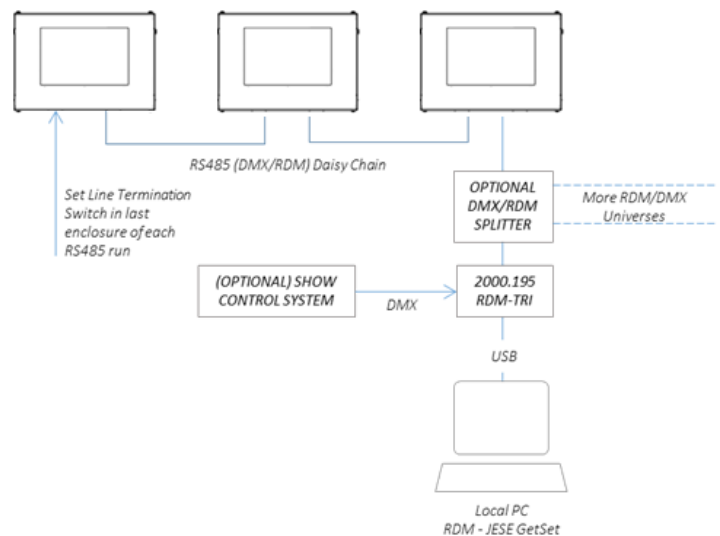

### 51.EN Ethernet Comms

Use this Ethernet adapter to connect one Cyclone or a group of Cyclones connected using RS485 to a PC, and monitor using Tempest TEMP protocol. Download the TEMP Developer Guide from [www.tempest.biz/tech-support](http://www.tempest.biz/tech-support).

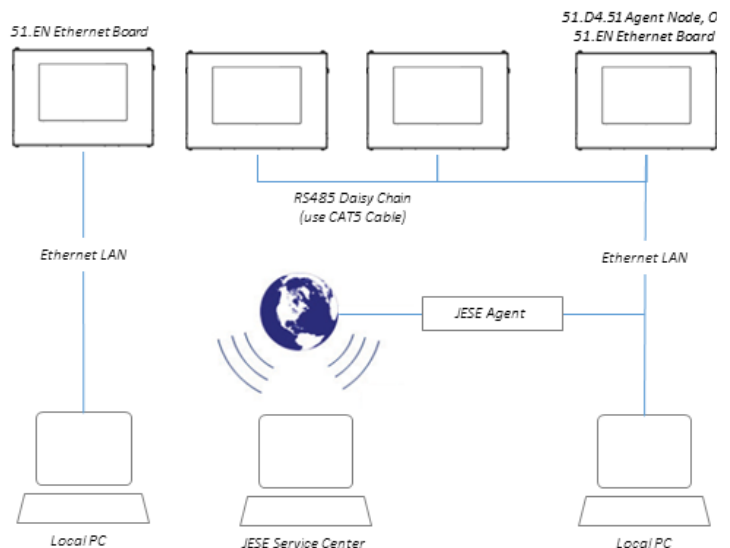

### JESE Agent - Global Monitoring

Now, there's Agent, from Tempest partner JESE — monitor larger systems in the site control room, or worldwide, from our UK-based control center — see more below...

# Zen Hush Projector Enclosures

With JESE's groundbreaking AGENT monitoring system, you can see exactly what's going on, in every one of those mission-critical enclosures.

And so can we...

We can log into your AGENT system from JESE's UK support center, and help you identify and fix problems — even upload new firmware to your enclosures if that's what you need.

### Low Risk — High Reward

For a very modest initial outlay, and an annual service fee, you can rest assured that your system will alert you to any potential or actual problems, and you will have access to system upgrades and real-time support, from experts who can see right into your system.

Low risk, very high reward.

## JESE Agent—Global Monitoring

And there's more...

AGENT supports the published ANSI DMX and RDM standards, so it can be used to monitor any compliant products, seamlessly with your Tempest enclosures.

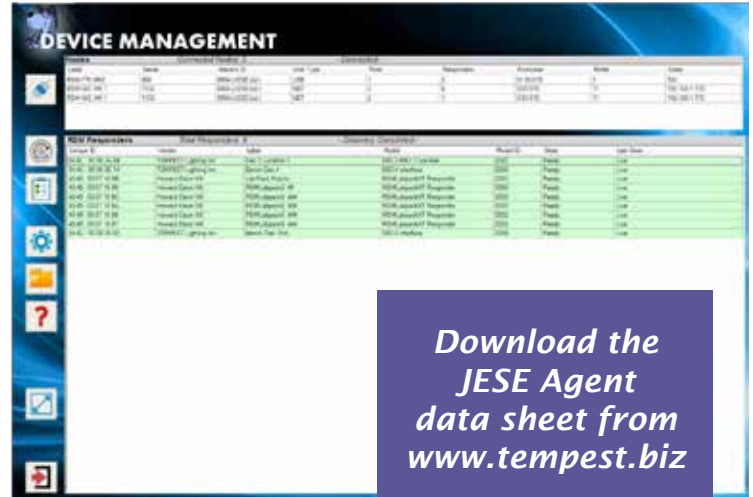

Download the  
JESE Agent  
data sheet from  
[www.tempest.biz](http://www.tempest.biz)



Remote Access  
over Internet

Windows PC  
running JESE  
Agent Client



# Zen Models

## Enclosure Dimensions

CAD Downloads: 2D DWG and PDF, 3D STEP files at [www.tempest.biz](http://www.tempest.biz)

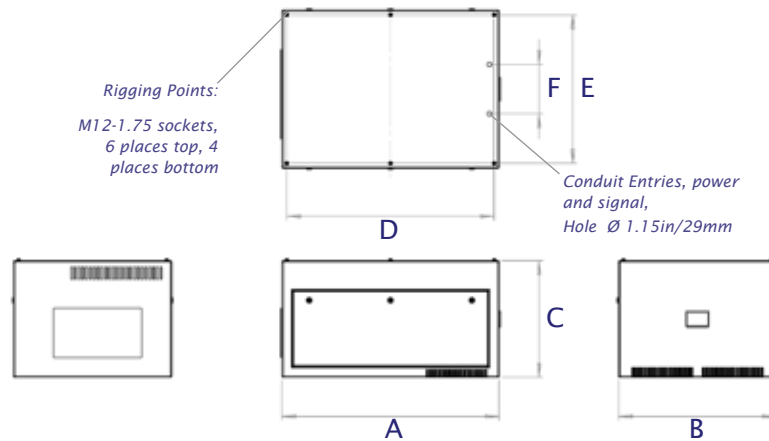

Model	Projectors	A (in/mm)	B (in/mm)	C (in/mm)	D (in/mm)	E (in/mm)	F (in/mm)	Weight
57.150.L	Most 10-15,000 Lumen Projectors *	46/1168	32/813	25/635	44/1118	30/762	10/254	185lb 84kg
57.210.L	Most 20,000 Lumen Projectors *	50/1270	35/889	28/711	48/1219	33/838	10/254	247lb 112kg
57.310.L	Most 25-30,000 Lumen Projectors*	59/1499	35/889	29/737	57/1448	33/838	10/254	302lb 137kg
57.320.L	Panasonic PT-RZ31K	67/1702	37/940	31/787	65/1651	35/889	10/254	387lb 176kg
57.324.L	Christie D4K40-RGB	57/1448	37/940	35/889	55/1397	35/889	10/254	421lb 192kg
57.324.P	Christie D4K40-RGB (Portrait)	57/1448	30/762	44/1118	55/1397	28/711	10/254	412lb 187kg

## Enclosure Power

All Zen models are suited to power supplies @ 90-260VAC, 50/60Hz.  
Max enclosure power consumption 200W

## Max Projector Dimensions/ Shipping Dimensions

Model	Typical Projectors	Max Length*	Max Width	Max Height	Max Power	Packed L (in/mm)	Packed W (in/mm)	Packed H (in/mm)	Packed Wt lb/kg	
57.150.L	Barco F80 Christie HS (16K) Panasonic PT-RZ12 (short lenses)	35/889	25/635	13/330	1500W	S H I P P I N G	55/1400	42/1070	38/970	275/125
57.210.L	Christie HS (20K) Panasonic PT-RZ12 (long lenses) Panasonic PT-DZ21K Panasonic PT-RZ21K	40/1016	28/711	16/432	2300W		59/1500	45/1140	41/1040	367/167
57.310.L	Barco UDX Christie Boxer/Crimson	49/1245	28/711	17/432	3500W		68/1730	45/1140	42/1070	442/201
57.320.L	Panasonic PT-RZ31K	57/1448	30/762	22/432	4000W		76/1930	47/1190	44/1120	537/244
57.324.L	Christie D4K40-RGB	45/1143	30/762	22/559	4000W		67/1700	47/1190	52/1320	591/269
57.324.P	Christie D4K40-RGB	45/1143	30/762	22/559	4000W	67/1700	40/1020	60/1520	582/264	

\* Max length including lens, cables, connectors

All Schedule B Export Code: 9405.99.0000

## Custom Colors

All the enclosures in this brochure are shown in our standard warm white semi-gloss finish or black. Any RAL color available to special order.

## Options

57.UR.xxx	Unistrut Rail Kit (Use the 3-digit enclosure model #, eg 57.UR.210 for Zen 57.210)	57.707.150	Replacement Inlet Filter Zen 150
		57.707.210	Replacement Inlet Filter Zen 210, 310
		57.707.320	Replacement Inlet Filter Zen 320, 324
51.EN	Ethernet Comms	0000.CL	Custom Color — specify any RAL #, plus % gloss desired
51.D4.51	JESE Agent 1-port node board		
51.JA.xxx	JESE Agent Monitoring System - consult factory		

# Zen Configurator

Please complete this form and email to us at [info@tempest.biz](mailto:info@tempest.biz)

Name	
Company	
Email	
Phone	
Projector type	
Zen Model	57. _____
Quantity	
Destination Country	
Install Date	
Projector Slide	Left <input type="checkbox"/> Right <input type="checkbox"/> <i>(Picture shows left slide)</i>
Unistrut Kit	Yes, Qty _____ No <input type="checkbox"/>
Ethernet Bridge	Yes, Qty _____ No <input type="checkbox"/>
Spare Inlet Filter	Yes, Qty _____ No <input type="checkbox"/>
Color	Standard, Warm White <input type="checkbox"/> Standard, Black <input type="checkbox"/> Custom, RAL # _____ Gloss Level * _____% <i>* Gloss levels higher than 30% may show up weld marks. Tempest advises against high gloss finishes and accepts no liability in this event.</i>

Projector Power Outlet *(all types include 2 x IEC 60320 C13 Aux Power):*

IEC 60320 C19 20Amp \_\_\_\_\_

IEC 60309 30/32Amp \_\_\_\_\_

Custom (specify) \_\_\_\_\_

Custom Requests:

Factory Use Only:	
SO Number	
Date	



User manuals,  
2D and 3D CAD  
drawings at  
[www.tempest.biz](http://www.tempest.biz)