



User Manual

Cyclone G4

Revision 03.0

March, 2020

© Tempest Lighting, Inc.



Table of Contents

| | |
|--|----|
| Table of Contents..... | 2 |
| Approvals – Europe | 5 |
| Approvals – China | 6 |
| Introduction | 7 |
| IMPORTANT: Safety Advisories | 7 |
| Installation..... | 8 |
| Dimensions, Rigging Points, and Maximum Projector Dimensions/Power | 8 |
| Access Clearance | 9 |
| Snow Clearance | 9 |
| Mounting Hardware Options | 10 |
| Mounting Bolts | 10 |
| Mounting Options – Unistrut Kit | 10 |
| Mounting Options – Stacking Kit | 11 |
| Mounting Options – Swivel Stacking Kit..... | 11 |
| Cycloator 2 Tilt Kit..... | 12 |
| SAFETY WARNING..... | 12 |
| Cycloator – Unistrut Mounting Rails..... | 12 |
| Cycloator – Inlet Cowl | 12 |
| Fixing the Cycloator in Place | 13 |
| Mounting the Enclosure..... | 14 |
| Setting the Show Position Stop..... | 15 |
| ActiveCool™ Cooling System | 16 |
| Salt Fog Filter Kit Installation | 17 |
| Anti-Vibration kit Installation..... | 17 |
| Important – Note these Warnings:..... | 18 |
| Mounting Hole Patterns..... | 19 |
| Connecting the Air Hoses..... | 20 |
| Power Connection | 20 |
| ActiveCool Control Settings | 20 |
| Set the ON/OFF Switch..... | 22 |
| ActiveCool dimensions | 23 |
| Wiring the Enclosure | 24 |
| Power Wiring | 24 |
| SAFETY NOTICE | 24 |
| Electrical Standards..... | 24 |
| Wiring Access..... | 25 |
| Cyclone G4 User Manual | 2 |

| | |
|---|----|
| One or Two Power Circuits? | 26 |
| Single Feed Power Termination..... | 27 |
| Split Feed Power Termination | 27 |
| AC Supply Voltage..... | 27 |
| North America 208V, Japan 200V Single Feed..... | 28 |
| North America 208V, Japan 200V Split Feed | 29 |
| International, 230V Single Feed..... | 30 |
| International, 230V Split Feed | 31 |
| Remote Monitoring Connections | 32 |
| RS485 (DMX/RDM) Cable Terminations..... | 33 |
| Line Termination Switch Settings | 34 |
| DEC4 Ethernet Adapter – 51.EN | 35 |
| Default Configuration..... | 35 |
| Additional Support | 35 |
| Tempest Equipment Management Protocol | 36 |
| Projector Power Control using DMX512 | 37 |
| DMX/RDM Network, using JESE RDM-TRI..... | 38 |
| Positive Pressure Fan Control Option..... | 39 |
| Digital Enclosure Control..... | 40 |
| Schematic..... | 40 |
| DEC4 Main Functions | 41 |
| Firmware Revision | 41 |
| Factory Settings – Data Modes..... | 41 |
| Hardware Indicators & Fuses..... | 42 |
| Operating Modes..... | 43 |
| RDM Only Monitor (Factory Default) | 43 |
| RDM+DMX Control..... | 43 |
| RDM+DMX Service | 43 |
| DEC4 Control Parameters | 44 |
| Control Interface | 45 |
| User Interface LCD Display..... | 46 |
| Control Interface Operation | 46 |
| Control Menu..... | 47 |
| Set Data Options..... | 47 |
| Set Temp Units | 48 |
| Set Temp Ranges | 48 |
| Set Max Humidity | 48 |
| Set Lamp On Point..... | 48 |

| | |
|--|----|
| Reset Lamp Hours..... | 49 |
| Set Fan Function..... | 49 |
| Status Display..... | 49 |
| Safe Mode..... | 50 |
| Safe Mode – What to do:..... | 50 |
| DEC4 Firmware Updates..... | 52 |
| Indirect Firmware Updates..... | 52 |
| Requirements..... | 52 |
| Installation Procedure..... | 52 |
| Mounting the Projector..... | 57 |
| Important: Check Lamp-on Current..... | 57 |
| Projector Slide Configuration..... | 57 |
| Changing the Projector Slide Direction..... | 58 |
| Securing the Projector (Landscape)..... | 58 |
| Portrait Projector Mounts..... | 59 |
| Connect Projector and Aux Equipment..... | 60 |
| Projector-specific Mounting..... | 61 |
| Christie D4K-40 RGB - Landscape..... | 61 |
| Christie D4K-40 RGB – Portrait..... | 62 |
| Christie J-Series/Roadster Family..... | 63 |
| Barco HDX..... | 63 |
| DPI Insight 4K..... | 64 |
| Routine Maintenance..... | 65 |
| Clean Port Glass..... | 65 |
| Check Filter..... | 65 |
| Check Temperature/Humidity Sensor..... | 66 |
| For After Sales Support..... | 66 |
| Troubleshooting..... | 67 |
| Warranty..... | 68 |
| Appendix – TEMP Protocol..... | 69 |
| Physical Layer..... | 69 |
| Developer’s Guide..... | 69 |

Approvals – Europe

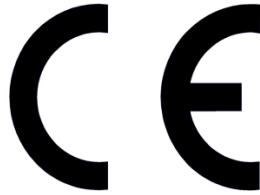

CERTIFICATE AND DECLARATION OF CONFORMITY
FOR CE MARKING

Tempest Lighting, Inc.

11845 Wicks Street, Sun Valley, CA 91352, USA

t: +1 818 787 8984 f: +1 818 252 7101 e: info@tempest.biz

www.tempest.biz

Tempest Lighting, Inc. declares that their

Cyclone G4 Projector Enclosure Series 55.xxx.xx

complies with the Essential Requirements of the following EU Directives:

Low Voltage Directive 2006/95/EC

Test Report G4.51.LVD

Electromagnetic Compatibility Directive 2004/108/EC

Test Report G4.51.EMC

and further conforms with the following EU Harmonized Standards:

EN 60065 : 2002

Test Report 60065.G4.51.01

EN 60529:2001-2002

Test Report 60529.G4.51.02

EN 61000-6-3:2007+A1:2011

Test Report 61000.G4.51.03

EN61000-6-1:2007

Test Report 61000.G4.51.03

EN55015:2006+A2:2009

Test Report 61000.G4.51.03

Dated: 1st July 2016

Position of signatory: President

Name of Signatory: Tim Burnham

Signed below:

on behalf of Tempest Lighting, Inc.



.....

Approvals – China



强制性认证目录外产品确认书
**Confirmation Letter for Products
 Outside the Scope of China Compulsory Certificate**

Ref. No: CL-TEMPEST-160818-1

| | | |
|---|--|--|
| 申请人: Applicant: Tempest Lighting Inc. | | 地址: Address: 11845 Wicks St., Los Angeles, CA 91352 United States |
| 生产厂名称: Factory: Tempest Lighting, Inc. | | 地址: Address: 11845 Wicks St., Los Angeles, CA 91352, USA |
| 产品名称: Product Name: 投影仪外壳, 灯具外壳 Projector Enclosures Moving Light Enclosures Lighting Enclosures | 型号: Model: 18xx.IN, 19xx.IN, 2xxx.IN, 66xx.IN, 52.xxx.IN, 53.xxx.IN, 54.xxx.IN, 55.xxx.IN, 56.xxx.IN | 商标: Trademark: Tornado, Twister, Thunder, Blizzard, Whispr, Typhoon, Cyclone, Tacit |
| 产品标准: Standard: / | | HS code: 9405.99.0000 |
| 产品描述(包括使用场所) Product Description (utilization of product) : Enclosures for high-powered luminaires and video projectors for outdoor use and indoor noise attenuation. For professional use only. 产品为用于户外和室内噪声衰减大功率灯具和视频投影仪的外壳。仅供专业使用。 | | |
| 确认意见 Conclusion: According to the product description, the models above are out of CCC scope 基于产品描述, 如上型号的产品在中国强制性产品目录之外。 本确认书的有效有效期至: August 18th, 2017 Validity Period | | |



Introduction

Thank you for purchasing a Tempest enclosure! We have worked hard to provide you with the very best product available for its purpose, and we shall continue to do everything possible to ensure that it works well for you for many years to come.

Please read this manual before starting work!

In the event of difficulty, please contact your Tempest reseller or Tempest direct:

info@tempest.biz

+1 818 787 8984

We will do everything we can to help you get the very best results from your Tempest enclosure.

IMPORTANT: Safety Advisories

- All installation and rigging work done must where applicable be designed and built in accordance with norms and standards of the local authority having jurisdiction of the installation site. It is the responsibility of the installer to obtain such approvals as may be required to achieve full compliance.
- All electrical work must be carried out by a suitably licensed electrical contractor in full compliance with local electrical standards.
- Lifting: some enclosures and the equipment inside them may be heavy. Use properly rated lifting equipment where appropriate and never attempt to carry out work with fewer than the number of workers needed to lift safely.
- It is the responsibility of the installer to ensure that all local building, safety and electrical codes are strictly adhered to in the installation of this enclosure. Tempest Lighting, Inc., its employees and agents are in no way responsible for damage arising from failure to follow either the instructions in this manual or building, safety and electrical codes prevailing at the installation location.
- Do not attempt to install or operate the enclosure before fully reading and understanding this manual
- Never allow anyone who has not read this manual to open the enclosure or perform maintenance on the projector within.
- Never leave the enclosure unattended when open.
- Always make sure all bolts and latches are tight and safety locks are in place after performing any form of maintenance on the unit.
- Do not open any electrical boxes until power has been shut off to all supply lines to the enclosure (including the one powering the projector).
- Do not open the enclosure in wet weather.

Installation

Dimensions, Rigging Points, and Maximum Projector Dimensions/Power

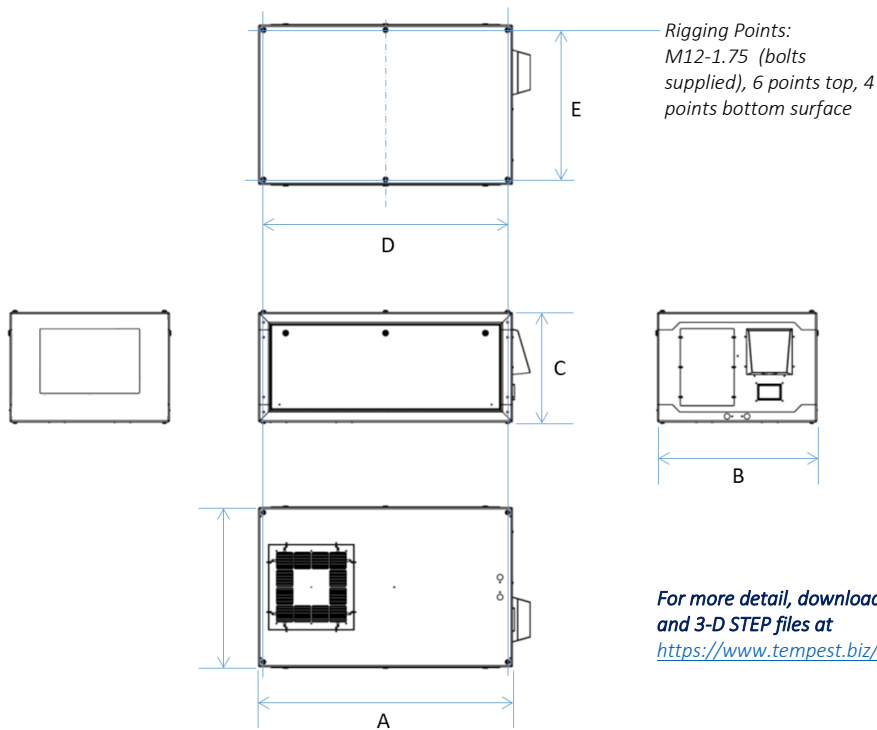

For more detail, download 2-D PDF or DWG and 3-D STEP files at <https://www.tempest.biz/product/cyclone/>

| Model | Projector Type | Format | A (in/cm) | B (in/cm) | C (in/cm) | D (in/cm) | E (in/cm) | Weight |
|----------|---|-----------|-----------|-----------|-----------|-----------|-----------|-------------|
| 55.210.L | Panasonic PT-DZ21K, RZ21K, Barco F90, DPI Highlite 4K, Titan Quad | Landscape | 51"/130 | 32"/81 | 22"/56 | 49"/124.5 | 30"/76.2 | 145lb/66kg |
| 55.210.P | | Portrait | 51"/130 | 25"/64 | 34"/86 | 47"/124.5 | 23"/58.4 | 175lb/80kg |
| 55.240.L | Christie Roadster, Barco HDX | Landscape | 53"/135 | 34"/86 | 26"/66 | 51"/129.5 | 32"/81.3 | 190lb/86kg |
| 55.240.P | | Portrait | 53"/135 | 25"/64 | 34"/86 | 51"/129.5 | 23"/58.4 | 182lb/83kg |
| 55.250.L | Epson Pro L25000 | Landscape | 51"/130 | 38"/96 | 24"/61 | 49"/124.5 | 36"/91.4 | 188lb/86kg |
| 55.250.P | | Portrait | 51"/130 | 25"/64 | 41"/104 | 49"/124.5 | 23"/58.4 | 212lb/96kg |
| 55.310.L | Christie Boxer, Crimson, Barco UDX, DPI Insight 4K | Landscape | 59"/150 | 34"/86 | 25"/64 | 57"/144.8 | 32"/81.3 | 203lb/92kg |
| 55.310.P | | Portrait | 59"/150 | 25"/64 | 36"/91 | 57"/144.8 | 23"/58.4 | 224lb/92kg |
| 55.320.L | Panasonic PT.RZ31K, Barco HDF | Landscape | 67"/170 | 38"/97 | 27"/69 | 65"/165.1 | 36"/91.4 | 247lb/112kg |
| 55.320.P | | Portrait | 67"/170 | 28"/71 | 41"/104 | 65"/165.1 | 26"/66.0 | 260lb/118kg |
| 55.324.L | Christie D4K35, CP2420, 2430 | Landscape | 62"/157 | 38"/96 | 34"/86 | 60"/152.4 | 36"/91.4 | 260lb/118kg |
| 55.324.P | | Portrait | 62"/157 | 31"/79 | 40"/102 | 60"/152.4 | 29"/73.7 | 280lb/127kg |
| 55.525.L | Panasonic PT-RQ50K | Landscape | 67"/157 | 38"/97 | 29"/74 | 65"/165.1 | 36"/91.4 | 280lb/127kg |
| 55.525.P | | Portrait | 67"/157 | 29"/74 | 40"/102 | 65"/165.1 | 27"/68.6 | 300lb/136kg |

We are adding models all the time – check our web site for submittal drawings or consult factory for models not shown here

Access Clearance

Observe these minimum access clearances shown around your enclosure.

Enclosures may be placed side-by-side, with the projector slides opposite, but we recommend allowing clearance for service access on both sides wherever possible.

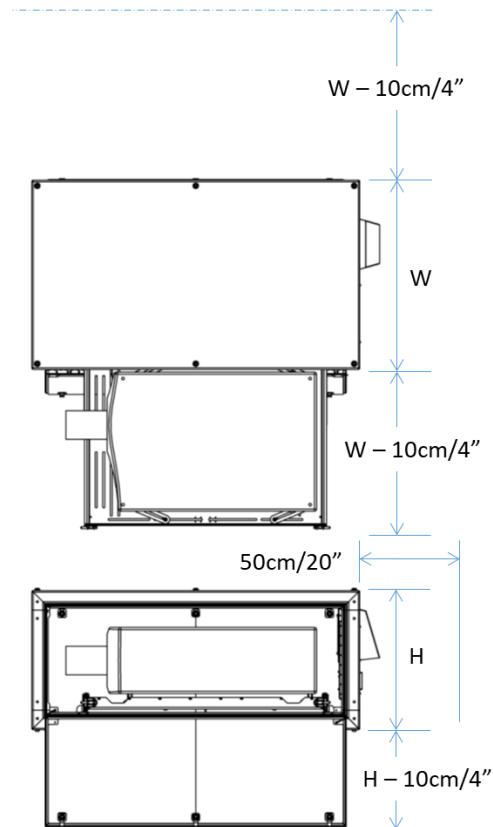

Snow Clearance

In areas where snow is likely, make sure the base of the enclosure is at least 24" [60cm] above highest potential snow drift level.

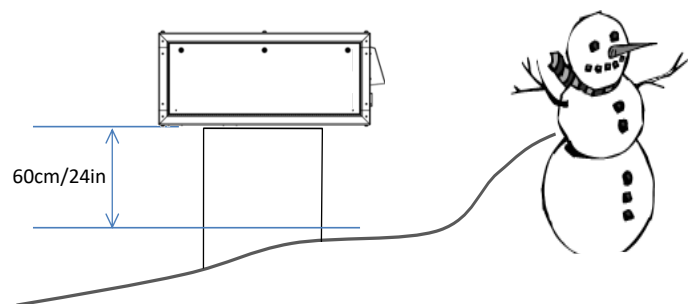

Mounting Hardware Options

Mounting Bolts

- Each Enclosure must be mounted with at least FOUR points (six points if hanging)
- All mountings must be made using the M12 threaded holes on the top or bottom of the enclosure.
- Be sure to use the sealing washers supplied for any top fixings.
- Use an 8mm hex key to secure the M12 socket cap screws provided.
- Tempest recommends the use of stainless steel mounting hardware.
- Make sure the inlet filter has at least 75mm/3in clearance below.

IMPORTANT SAFETY NOTICE

Installer must ensure that all mounting points are secure and conform to local safety regulations. Tempest Lighting Inc. accepts no responsibility for damage or injury arising from inappropriate or unsafe installation.

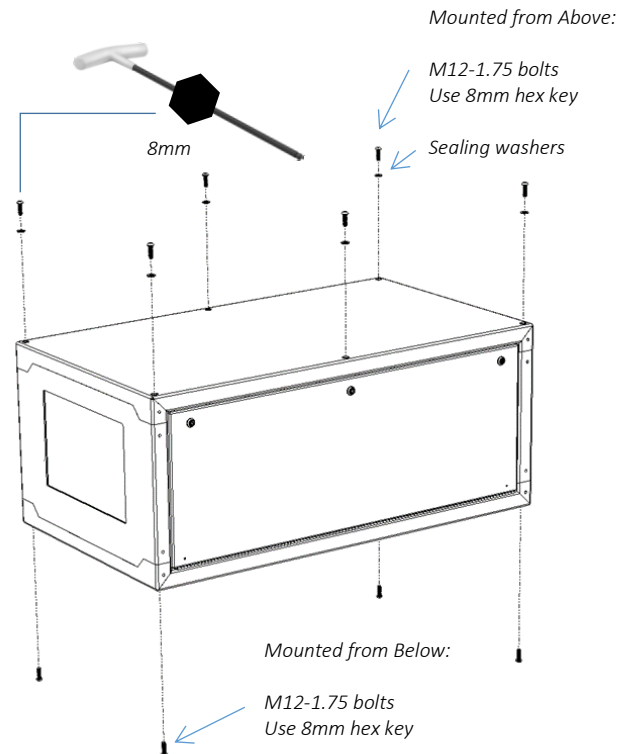

Mounting Options – Unistrut Kit

If mounting positions for the corner bolts are not convenient, use the Unistrut Kit (55.UR.xxx) to add two Unistrut rails to the top or bottom of the enclosure.

Using industry-standard Unistrut hardware, the enclosure may now be attached at any point along the Unistrut rails.

Note: Unistrut rails are required for use with the Cyclovator mount – see below...

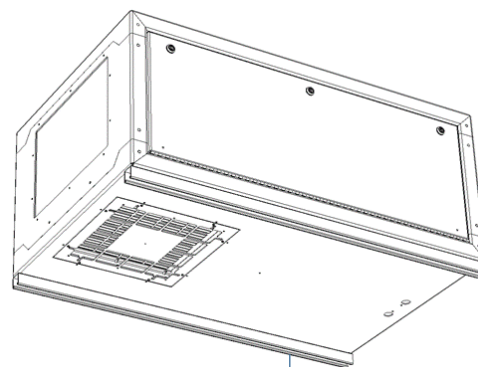

Unistrut Rails may be mounted above or below

Mounting Options – Stacking Kit

Cyclone G4 may be stacked up to three units high, using the 51.SK stacking Kit. You will need the total number of Cyclones to be stacked, minus one stacking kit(s).

So, for a stack of three enclosures, order 3-1=2 stacking kits.

Note: Cyclone enclosures must be of the same model to stack in this way.

51.SK Stacking Kit (set of four, for one enclosure)

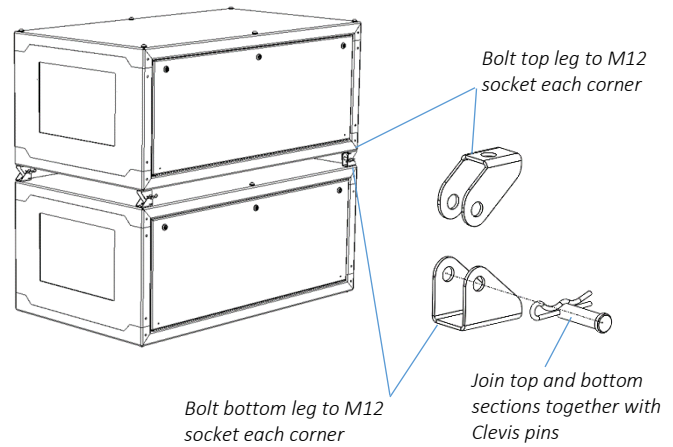

Mounting Options – Swivel Stacking Kit

Cyclone G4 may be stacked two units high, with beams up to 40° apart, using the Swivel Stacking Kit. Enclosures must be the same model.

This is very useful for edge-blending across a wide area with a limited number of rigging positions.

51.SS.xxx (where xxx is the Cyclone model number) Swivel stacking kit for two G4 Cyclone enclosures

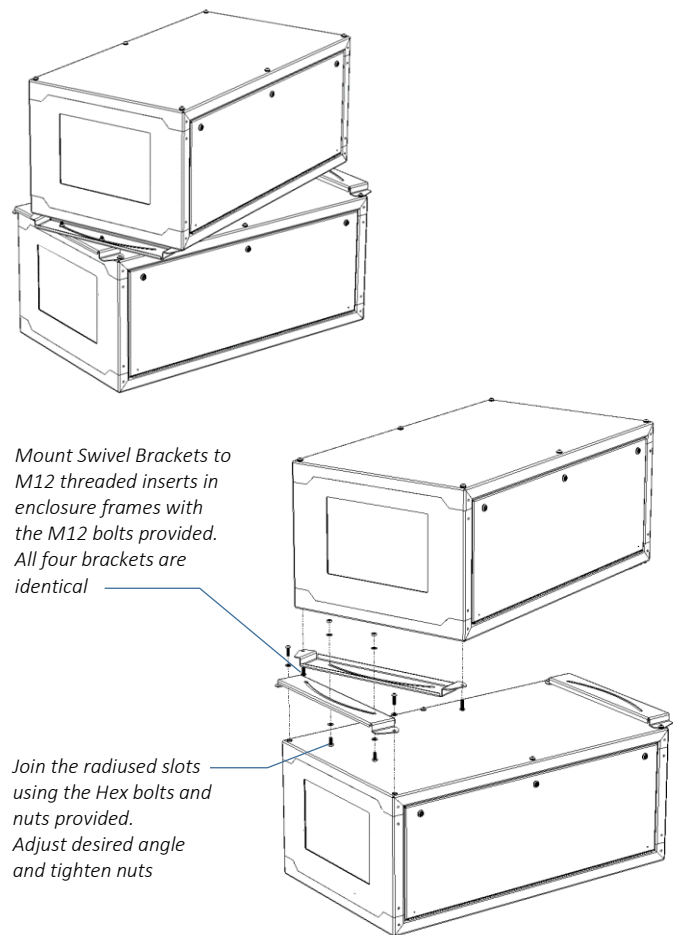

Cyclovator 2 Tilt Kit

SAFETY WARNING

IT IS A SAFETY REQUIREMENT that Cyclone enclosures with front or rear slide be horizontal any time you slide the projector out for service. IT IS DANGEROUS to do this if the enclosure is not horizontal, and MAY CAUSE DAMAGE TO THE PROJECTOR OR INFLICT SERIOUS INJURY TO PERSONNEL. Tempest Lighting Inc., its agents and employees, will not be liable for consequences of failure to heed this safety warning.

Cyclovator 2 may be used for any G3 or G4 Cyclone enclosure.

The enclosure may be installed at ground level, projecting up (up onto a building, for example)...

...or, on a rooftop, projecting downwards.

In either case, the maximum tilt angle is 60°.

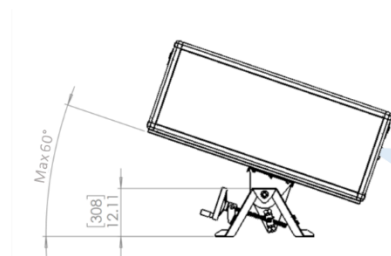
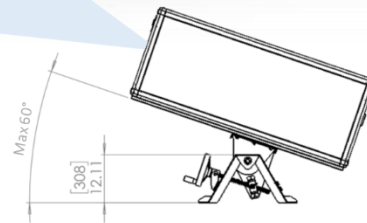

Cyclovator – Unistrut Mounting Rails

When Cyclone G4 is used with the Cyclovator Tilt Kit, the Unistrut Kit (55.UR.xxx) is required to attach the enclosure to the Cyclovator.

'xxx' is the Cyclone model number.

Cyclovator – Inlet Cowl

When Cyclone G4 is used with the Cyclovator Tilt Kit, with a tilt angle greater than 40°, use the inlet cowl 55.IC.xx to protect the inlet filter from weather.

'xx' is the filter size in inches – 15 for 55.200-350, 22 for 55.400 and up.

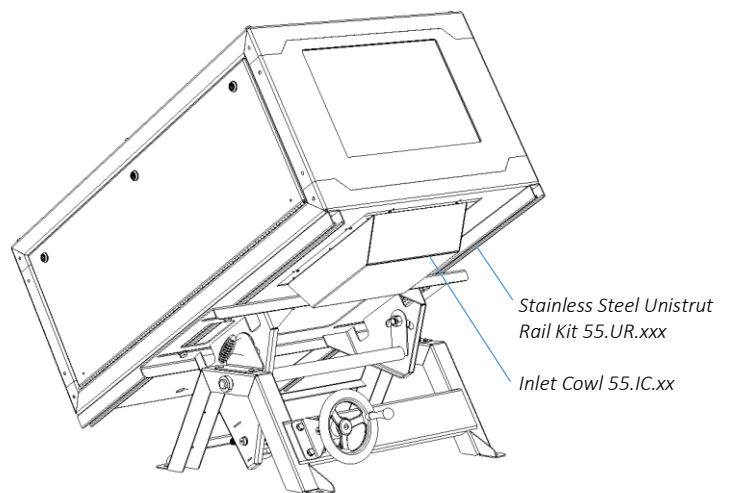

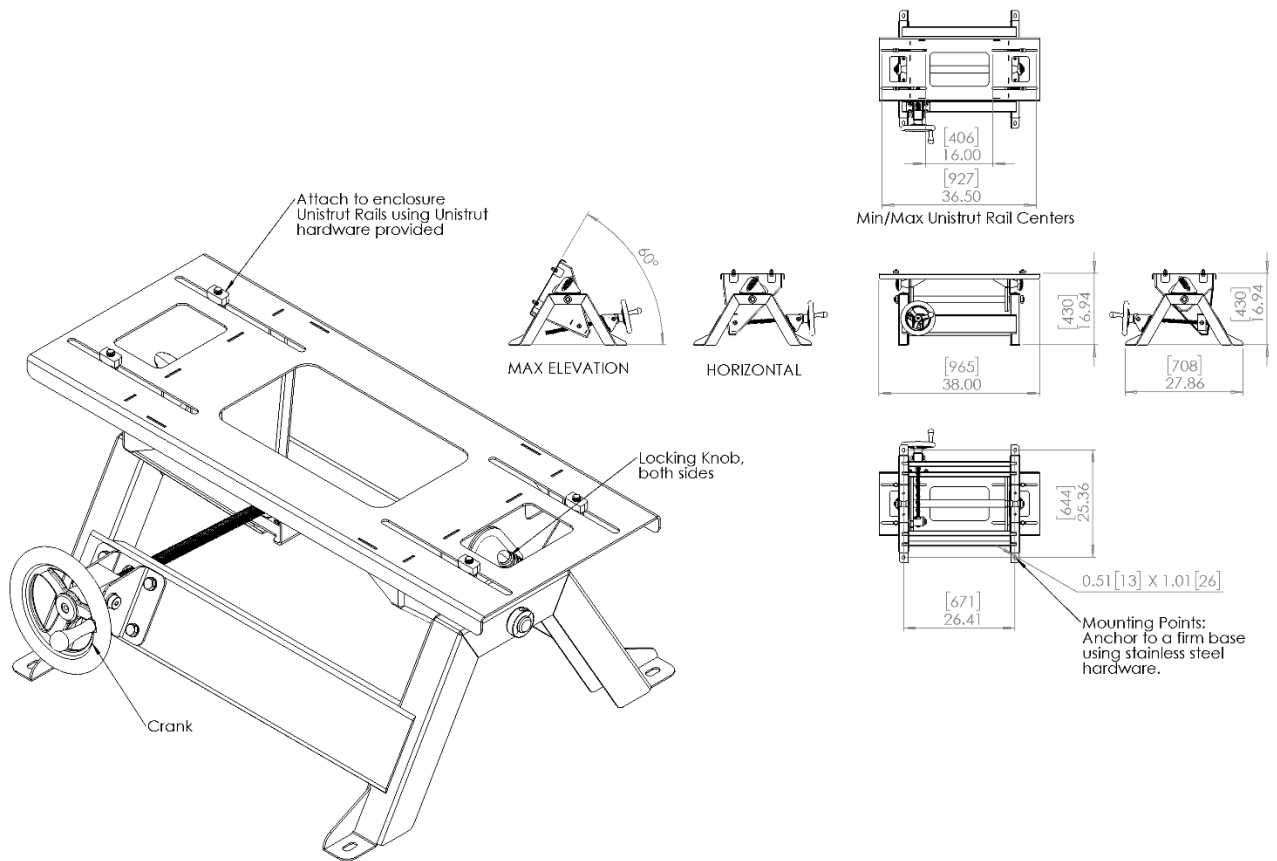

Fixing the Cyclovator in Place

The Cyclovator **MUST** be firmly attached to the ground, or a suitable mounting structure, using four stainless steel M12 (or US ½" size) bolts or anchors (not supplied).

Suitable substrates include concrete pads, steel frameworks, roof beams. All mountings must comply with all relevant building and safety norms in the jurisdiction of the final installation. It is the responsibility of the installer to obtain approval from a structural engineer or other competent person for all such installations, and to adhere strictly to local building and safety codes at all times.

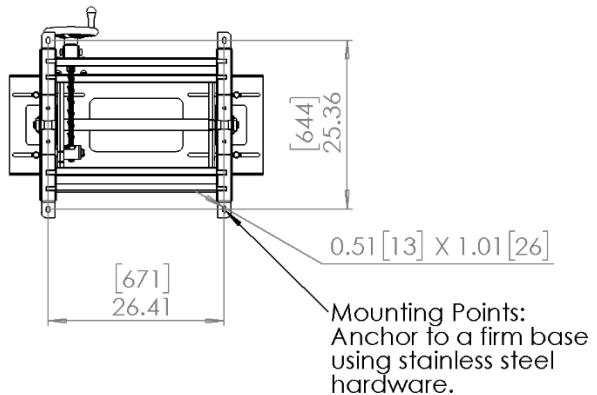

Mounting the Enclosure

(a)

Make sure that the Unistrut rails are attached securely to the 4 (or 6) M12 threaded sockets on the bottom of the enclosure frame.

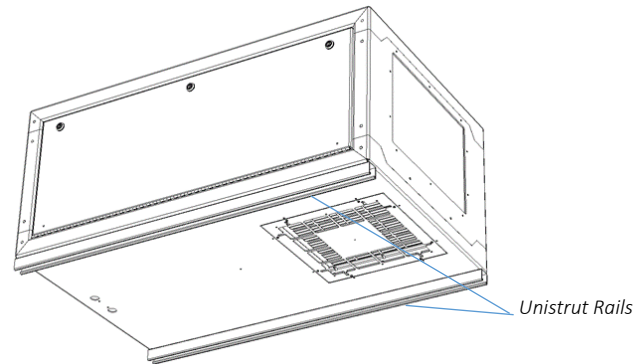

Set the Cyclovator to its horizontal position:

1. Loosen the two locking knobs (a)
2. Turn the crank handle (b) until the Cyclovator saddle is horizontal
3. Tighten the two locking knobs (a)

Align the channel spring nuts (c):

4. The distance (E) between the channel nuts should be the same as dimension E in the installation page (the distance between centers of the Unistrut channels)
5. Loosen the channel nut bolts and align the channel nuts with their long sides parallel with the end of the Cyclovator saddle:

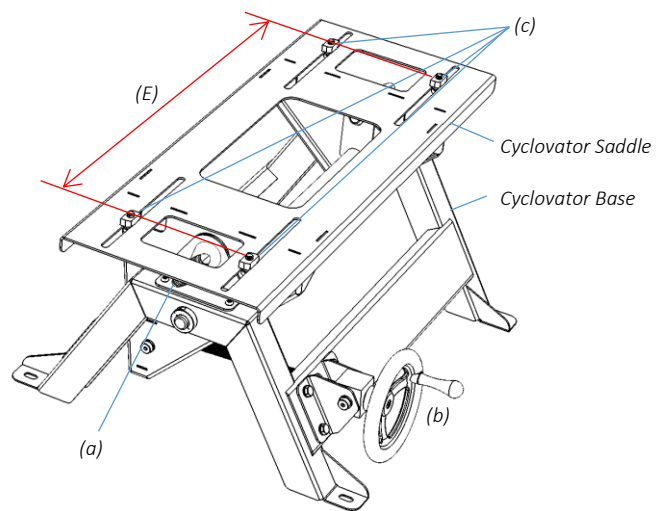
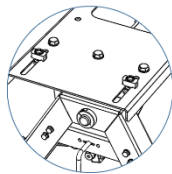

6. Carefully set the Cyclone enclosure on the Cyclovator saddle, so that the channel nuts are INSIDE the Unistrut rails.
7. PUSH UP and tighten the four M12 channel nut bolts, so that the channel nuts lock in the Unistrut channels.
8. Loosen the locking knobs and turn the crank handle to test movement.

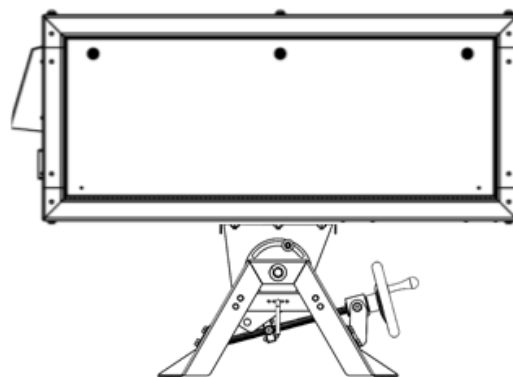

Steep Angles:

For steep projection angles, loosen the four channel nut bolts and carefully slide the enclosure in the direction that will be 'down'.

The center of gravity will still be roughly centered in show position, but you will have to work a bit harder to crank the enclosure up to its show trim!

It is important to use the Inlet Cowl accessory for angles above 40°.

Setting the Show Position Stop

Cyclovator gives you a locator for your show position, for accurate show positioning.

With the Cyclovator in Show position:

1. Loosen the Locking Collar set screw (a)
2. Slide the Locking Collar firmly against the Acme Nut Plate (b)
3. Tighten the Locking Collar nut (a)
4. You now have two reference locations:
 - Horizontal
 - Show

ALWAYS MAKE SURE THAT BOTH LOCKING KNOBS (c) ARE LOOSE WHEN RAISING/LOWERING THE CYCLOVATOR, AND TIGHT WHEN IN SHOW OR SERVICE POSITION.

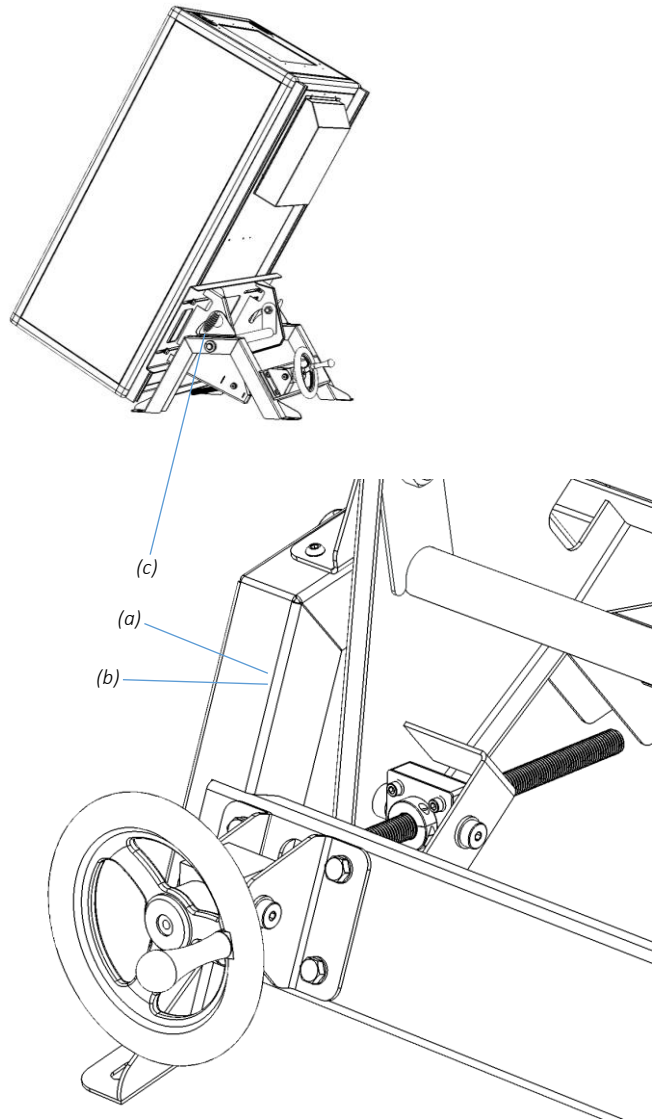

ActiveCool™ Cooling System

Tempest ActiveCool is a closed-loop cooling solution designed to keep sensitive laser projectors at a constant temperature in any outdoor environment.

ActiveCool comprises the following main components:

1. Cooler Unit
2. Flow hose (150mm/6in padded hose)
3. Return hose (250mm/10in padded hose)
4. Power cable (connects to PowerCon True TOP outlet on enclosure chassis)
5. Power relay added to enclosure controller
6. Optional salt fog filter and condenser exhaust door
7. Optional anti-vibration mounting kit

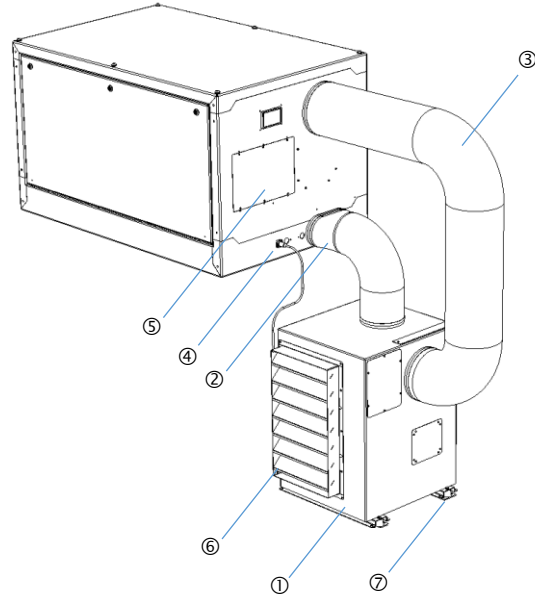

ActiveCool operation is automatic. Simply connect to the cyclone enclosure, and set the desired temperature, and the cooler will run automatically when:

- a) The DEC controller senses that the projector has come out of standby mode
- b) The projector is off but the upper temperature setting has been reached (normally during daytime under a hot sun).

The cooler will maintain an air temperature inside the enclosure within 2°C of the target temperature set in the ActiveCool controller.

The ActiveCool temperature is factory-set to 21°C, which should be appropriate in most cases, so setup is minimal.

Salt Fog Filter Kit Installation

1. Remove the screws around the condenser inlet and exhaust grilles.
2. Fit the salt fog filter (gold side out) inside the louver box.
3. Attach the filter/louver assembly to the cooler, using the screws removed in step 1.
4. Mount the exhaust door frame onto the condenser exhaust grille with the four screws provided.
5. Assemble the door, washers and stainless steel bearing, and fix to the door frame with the two screws provided. **MAKE SURE THE WASHERS ARE BETWEEN THE DOOR AND THE INSIDE OF THE DOOR FRAME.**

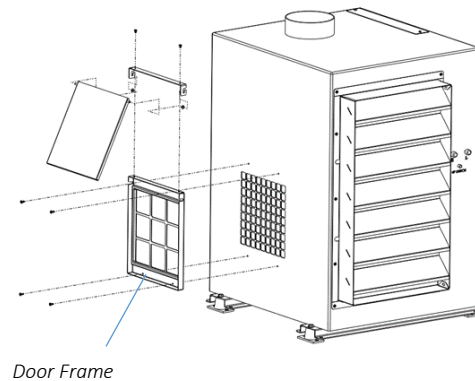
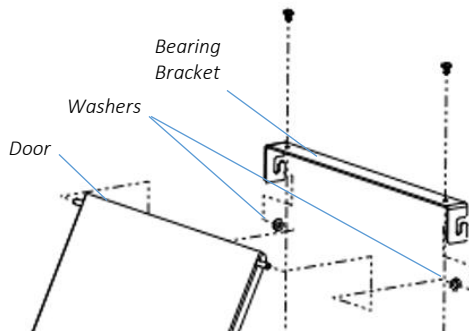
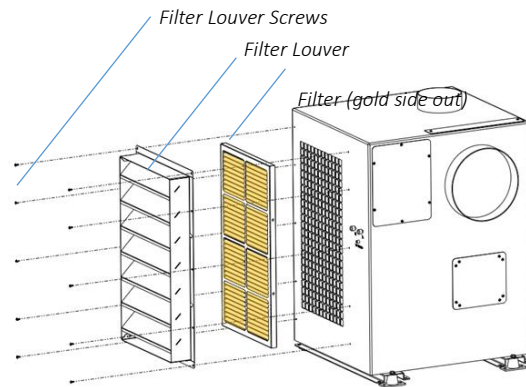

Anti-Vibration kit Installation

To avoid possible picture 'wobble', Tempest recommends the use of the optional anti-vibration mounting kit when:

- a) The cooler is mounted on the same structure as the projector enclosure, AND
- b) The projection throw is over 50m (150ft)

This should not be needed if the above conditions are not met.

Mount the four vibration pads to the middle holes in the cooler feet, using the hardware provided.

Mount the vibration standoffs to your structure using 8mm hardware (not supplied).

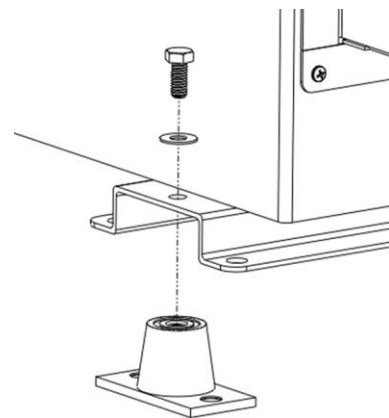

Important – Note these Warnings:

- 1) Always keep unit in upright position. Do not lay unit down. *If the unit is laid down, the unit must be placed upright and not turned on for at least 4 hours, or compressor damage may occur, due to compressor oil displacement.*
- 2) Filter should be changed as needed or at least once every 2 months. Remove filter from slot on top of unit by turning the 2 latch screws. The filter size is 305 x 305 x 25 (12" x 12" x 1"), Tempest part # 55.ACF.
- 3) If the hot air discharge flow is blocked from the intake or exhaust grilles, the unit will alarm and shut down to alert operators of the condition, correct the blocked air flow issue and press the **High Pressure (HP)** reset button located on back of unit, next to the service ports, which will clear the alarm. The unit will restart after the 3 minute time delay.

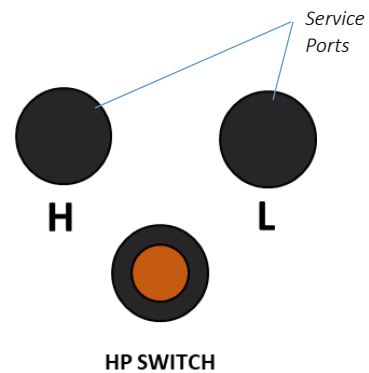
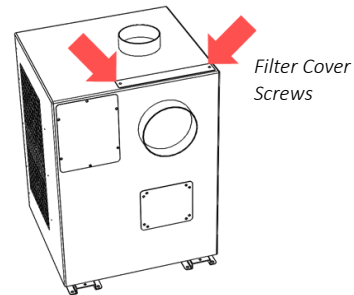
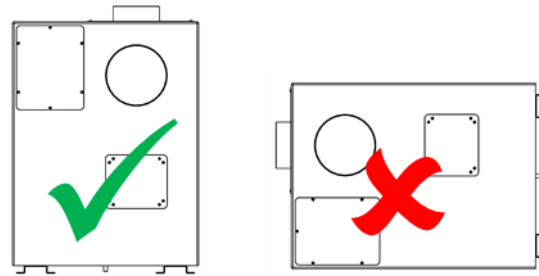

Mounting Hole Patterns

Hole patterns and mounting hardware (not included) are different for coolers with and without anti-vibration kits:

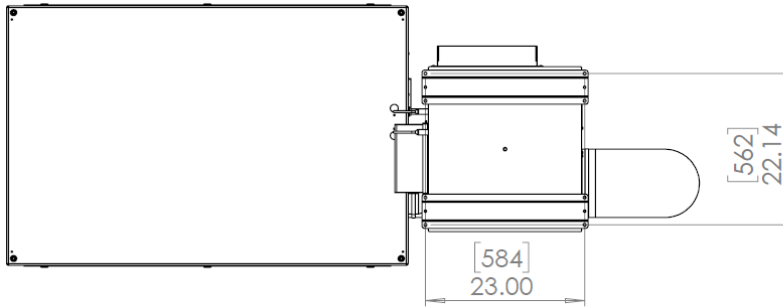

Mounting - Standard:
4 x M10 (3/8")

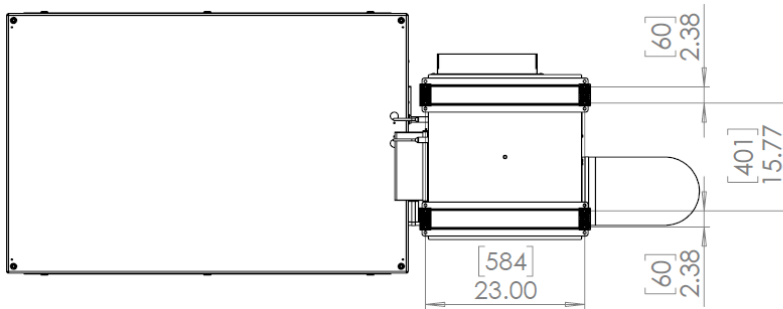

Mounting - Vibration Kit:
8 x M8 (5/16")

Connecting the Air Hoses

Cut the flow and return hoses to length and connect to the hose flanges on the cooler and enclosure, as shown above, using the stainless-steel hose clamps supplied.

Please note:

- Keep hoses as short as possible
- Avoid sharp bends where possible
- Make sure there are no kinks or obstructions to the air hoses.

IMPORTANT:

Maximum air hose length is 3m (10ft). Install the cooler close enough to the Cyclone enclosure so that these lengths will not be exceeded.

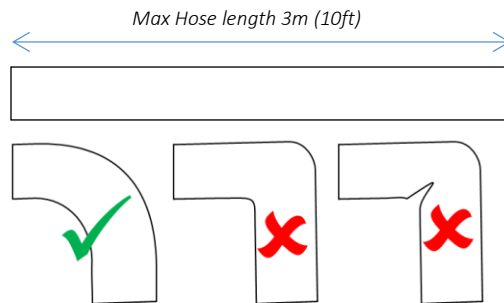

Power Connection

Plug the ActiveCool power cable into the Neutrik PowerCon True TOP outlet provided (*note, the **TOP** – Total Outdoor Protection – connector is fully outdoor-rated*).

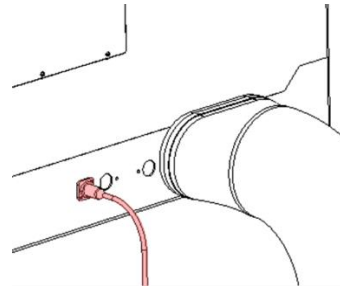

ActiveCool Control Settings

Remove the control cover, located below the return air ring:

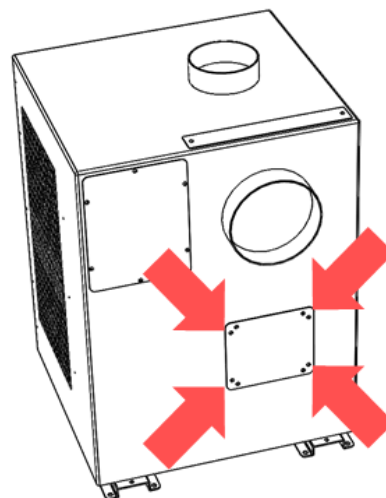

To accept the factory temperature setting of 21°C, skip to the next section

Set your controller: The controller is factory set at 21°C (72°F) and will be displaying the current supply air temperature. The controller is in cooling mode and is set to cycle within a 2 degree temperature range.

To change these settings:

PRESS [SET]. C is displayed. Use ↑ or ↓ to toggle between Celsius and Fahrenheit, the letter C or F is then displayed.

PRESS [SET] again, the current **TARGET TEMPERATURE** is displayed. Use ↑ or ↓ to change the target air temperature. *Note: For best results always set the unit to a realistic temperature that it can maintain.*

PRESS [SET] again. The number 2 is displayed. This is the temperature range setting – **DO NOT CHANGE.**

PRESS [SET] again. Display shows C1 (cooling mode) – **DO NOT CHANGE.** (the alternate setting is H1, meaning heat mode).

PRESS [SET] again. The unit displays the supply air temperature. This is the default display and the control will always reset to this display automatically.

This completes the “set” cycle routine.

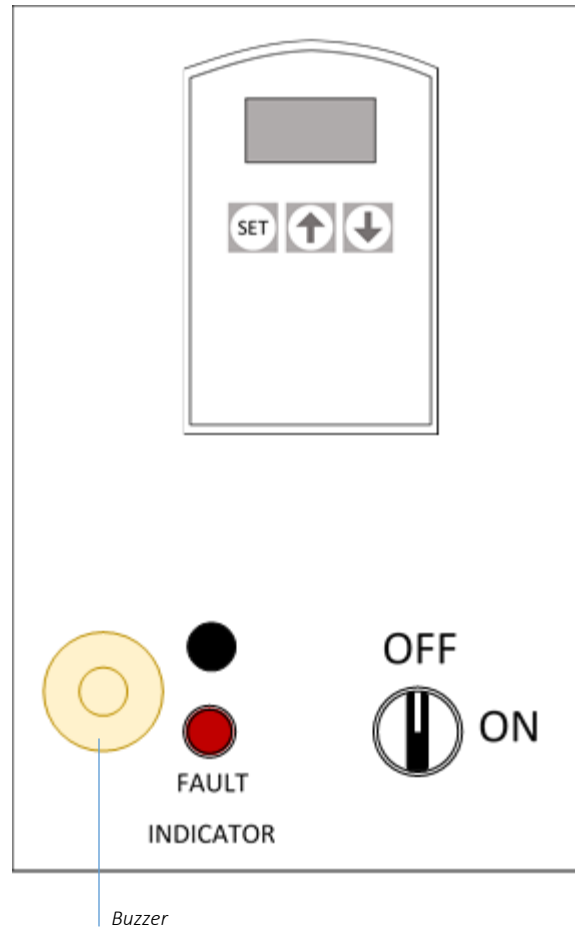

In the event of a fault, the buzzer will sound, and the fault indicator light will be lit.

Set the ON/OFF Switch

Turn the **ON/OFF selector switch** to **ON**. The evaporator fan starts and a three-minute time delay activates before the compressor starts. This prevents compressor damage due to short cycling.

After the time delay reaches three minutes the compressor starts, cooling will begin and the hot air exhaust fan will start.

Note that the evaporator fan is on continuously when the selector switch is in the ON position. The compressor runs continuously when the system is on and after the 3 minute time delay has elapsed.

To disable the cooler, turn the selector switch to the OFF position.

Replace the control cover. Your ActiveCool system is now ready for use.

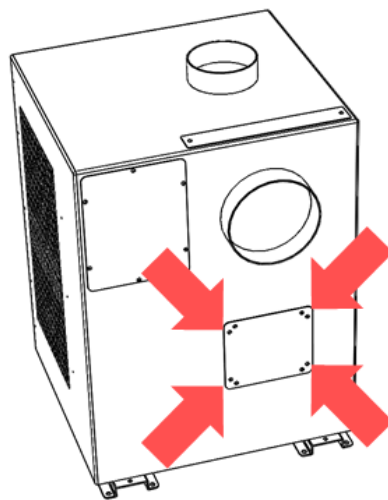
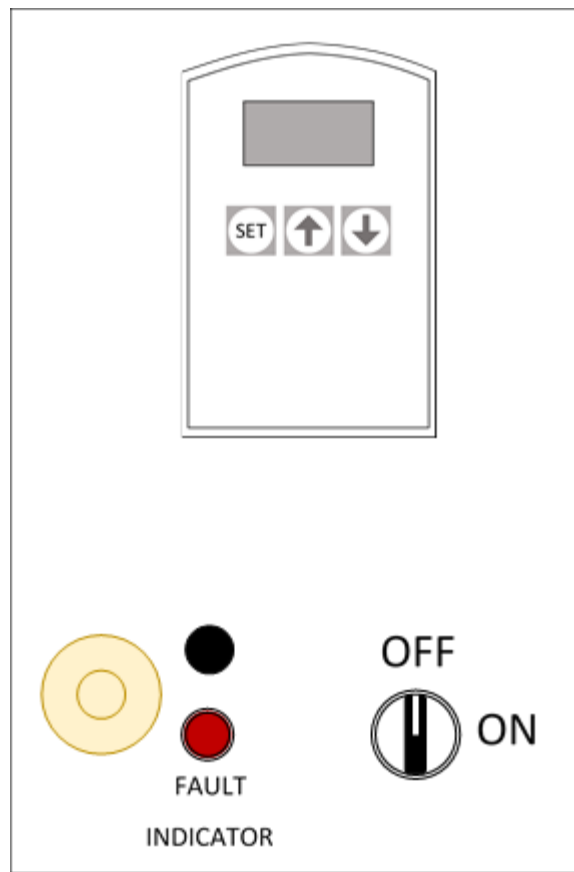

ActiveCool dimensions

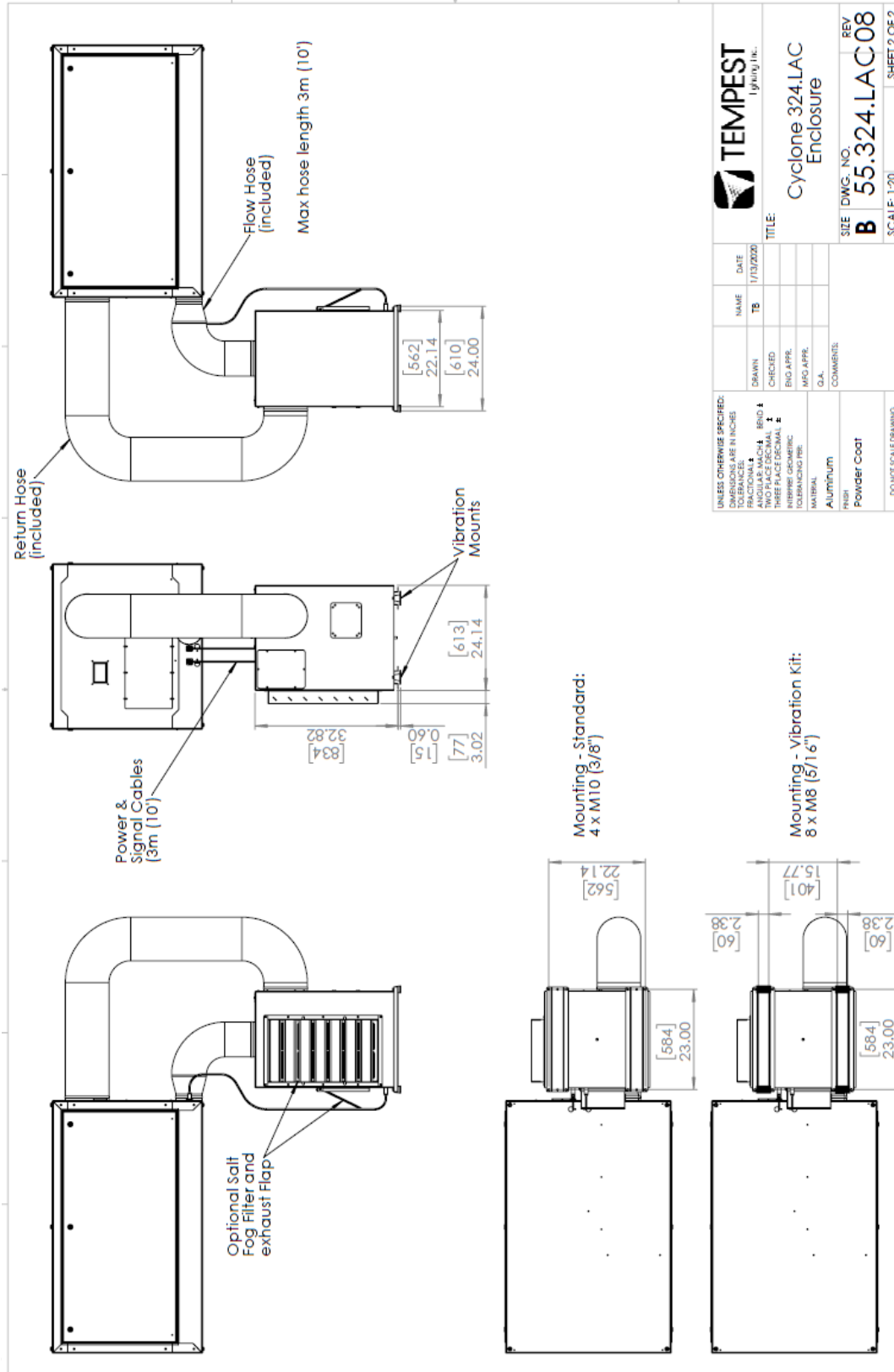

| | | |
|--|--------------------------------|--|
|  TEMPEST <small>Lighting Inc.</small> | | DATE 1/13/2020 |
| NAME TB | DRAWN 22.14 | CHECKED 610 |
| ENG. APPR. MFO APPR. | MFG. APPR. MFO APPR. | D.O.A. COMMENTS: |
| TITLE: Cyclone 324.LAC Enclosure | | SIZE DWG. NO. B 55.324.LAC.08 |
| SCALE: 1:20 | | REV SHEET 2 OF 2 |

UNLESS OTHERWISE SPECIFIED:
 DIMENSIONS ARE IN INCHES
 TOLERANCES:
 FRACTIONAL ± .005
 DECIMAL ± .005
 HOLE DIA ± .005
 HOLE POSITION ± .010
 HOLE DRILLING ± .005
 HOLE FINISH: ALUMINUM
 POWDER COAT

DO NOT SCALE DRAWING

Wiring the Enclosure

Power Wiring

SAFETY NOTICE

All power wiring must be performed by a competent electrician, appropriately licensed in the jurisdiction where the installation takes place. All electrical work must be done in full compliance with all electrical and safety norms applicable to the installation site. Isolate all power feeds before opening the enclosure.

Tempest Lighting, Inc., its employees and agents will not be held responsible for damage or injury caused by disregarding this notice.

Electrical Standards

Important:

Enclosure model numbers including **.US** are for use in countries using US and Japanese style electrical systems:

200-208VAC 50/60Hz

Enclosure model numbers including **.IN** are for use in countries using European style electrical systems:

220-250VAC 50/60Hz

Note:

- (1) Fans and Heaters are rated 200-250V
- (2) Electronics are autosensing for any voltage 90-265VAC, 50/60Hz

Wiring Access

Remove the wiring access plate on the rear surface.

Locate the conduit entry holes on the back and underside of the enclosure – you may use either set of conduit entries, depending on your installation needs.

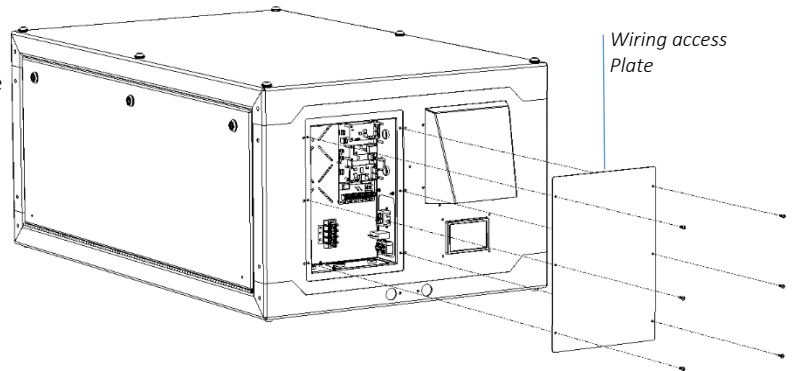

Note: Rear Panel layout may vary

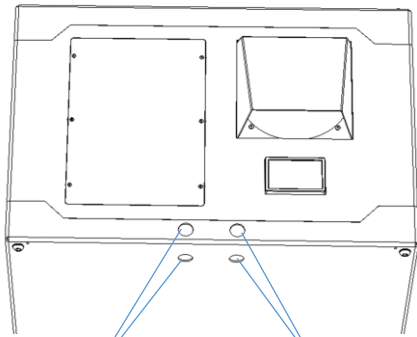

Conduit Entry:
AC Power

Conduit Entry:
Signal

Use a screwdriver – and tap lightly with a hammer if needed – to open the conduit knockouts.

Conduit openings accept PG21 (International) and 3/4" NPT (North America) conduit fittings.

Use permanent or flexible outdoor rated conduit to connect power and signal cables to your Cyclone enclosure.

ALWAYS RUN POWER AND SIGNAL CABLES IN SEPARATE CONDUITS.

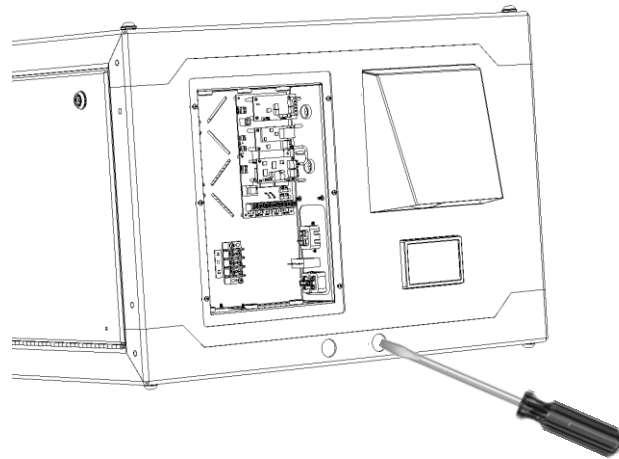

Identify the following parts:

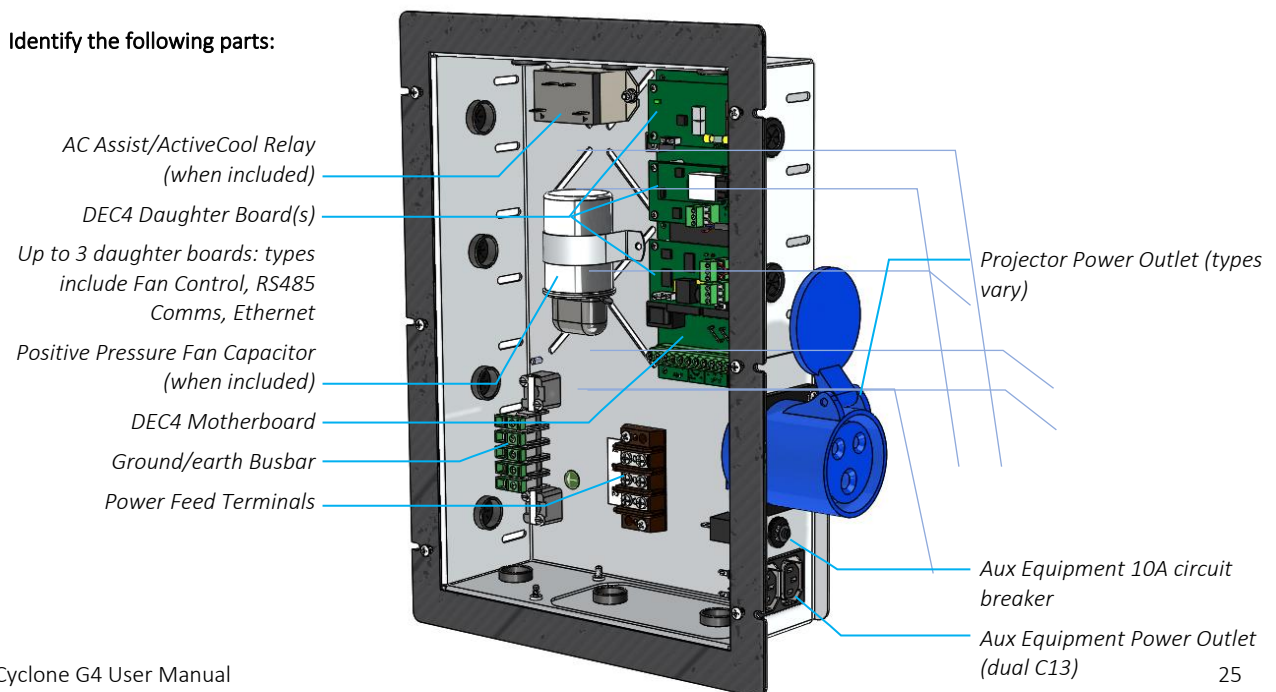

One or Two Power Circuits?

Tempest enclosures may be wired on single or double circuit supplies. On a single feed, both enclosure and projector are permanently on. With a split (double) feed supply, you can switch off the projector when not in use, while the enclosure continues to protect it 24/7.

Tip: most people use single feed.

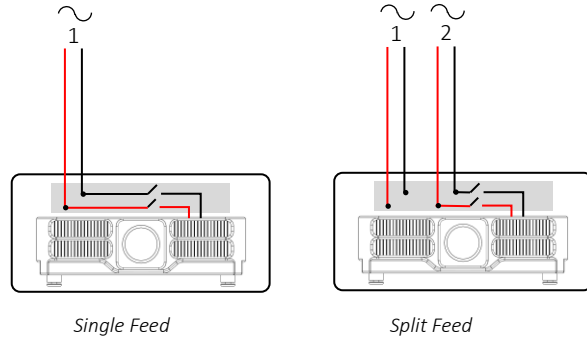

Single Feed

- Enclosure and projector are permanently on.
- Enclosure and Projector must be rated for the same voltage.
- Supply must be rated for projector current plus 150 watts.
- Supply must be permanently ON.

Split feed

- Enclosure power (FEED) must be permanently ON.
- Projector power (SPLIT) may be switched off.
- Enclosure power must be rated for 650 watts.
- Projector power must be rated for the projector (see projector manual).

Projector and enclosure power must be same voltage.

For **single feed** wiring, **no modification** to the DEC4 Controller motherboard is needed.

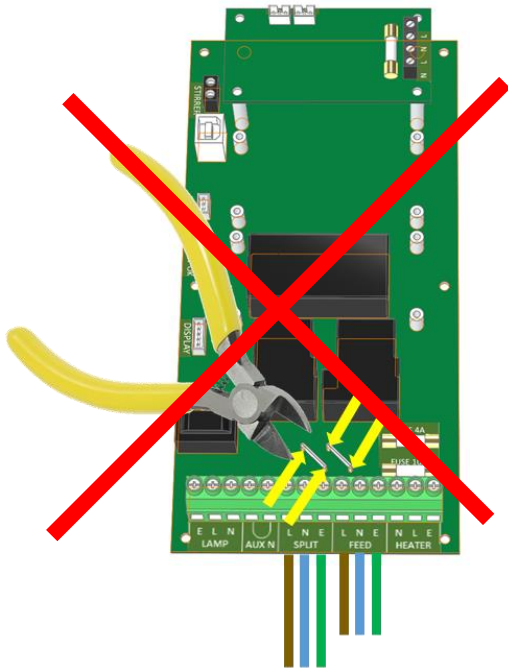

IMPORTANT:

For **split feed** wiring, use a side cutter to cut both AC links at both ends:

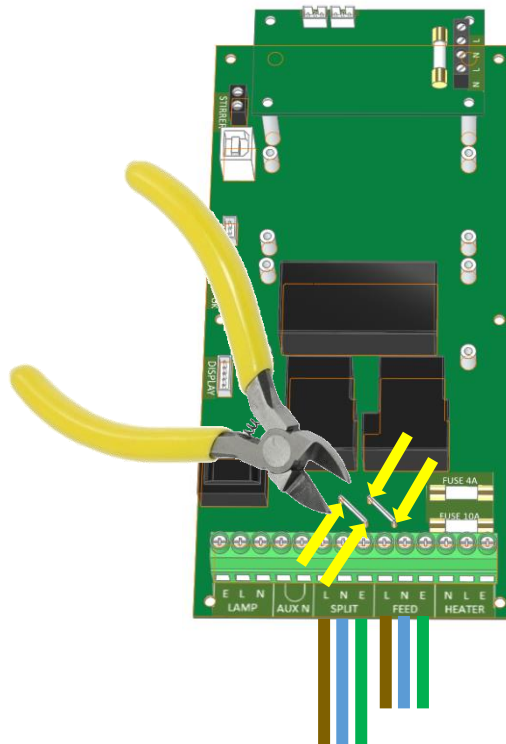

Single Feed Power Termination

- Connect Earth/Ground wire to Ground Terminal
- Connect Live and Neutral to the terminals marked **FEED**

SEE DIAGRAMS ON FOLLOWING PAGES

Split Feed Power Termination

- **STOP!** Did you cut the power links? See above.
- Connect Earth/Ground wire to Ground Terminal
- Connect Enclosure feed to the terminals marked **FEED**
- Connect Projector feed to the terminals marked **SPLIT**

SEE DIAGRAMS ON FOLLOWING PAGES

AC Supply Voltage

Tempest Cyclone enclosures require supply voltage in the nominal range 200-250VAC, 50/60Hz.

Tempest G4 enclosures are very tolerant of supply voltage variations:

- DEC4 controller has a universal power supply and operates on 90-265VAC
- Enclosure fans and heaters are rated 200-250VAC. Fans are over-dimensioned to cool adequately down to 200V, and heaters compensate thermostatically by increasing duty cycle on lower supply voltages.

North America 208V, Japan 200V Single Feed

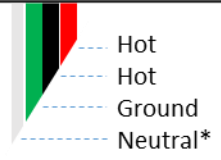
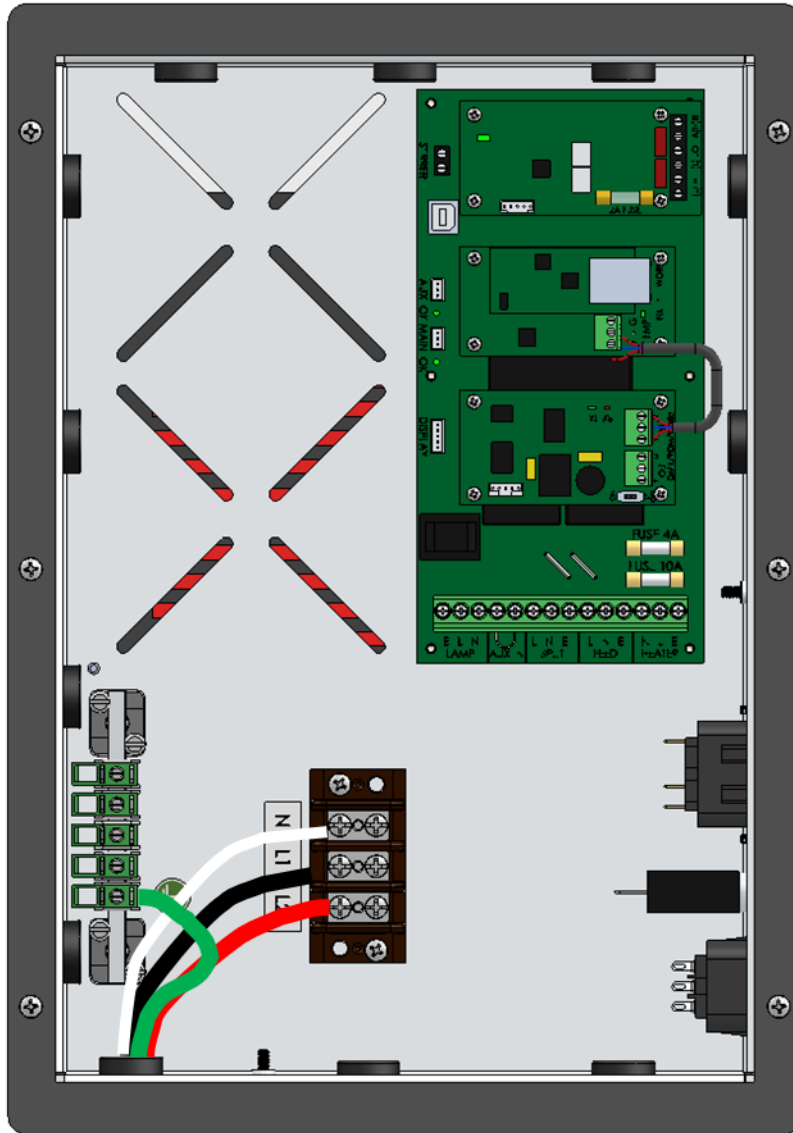

Single Feed

200-208VAC 30A Single-Phase (2 hots)

* 10A Neutral for 120V Aux power

(for clarity, internal wiring not shown)

North America 208V, Japan 200V Split Feed

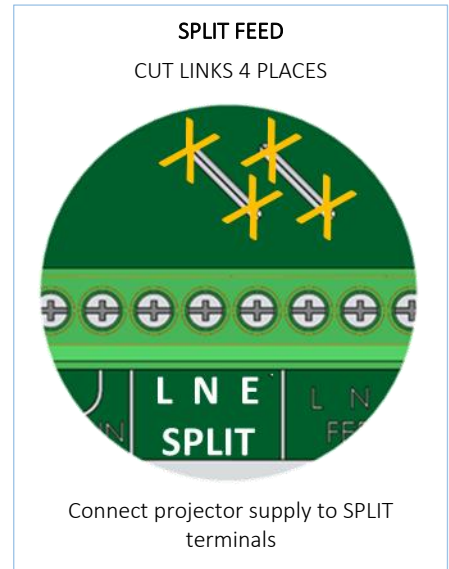
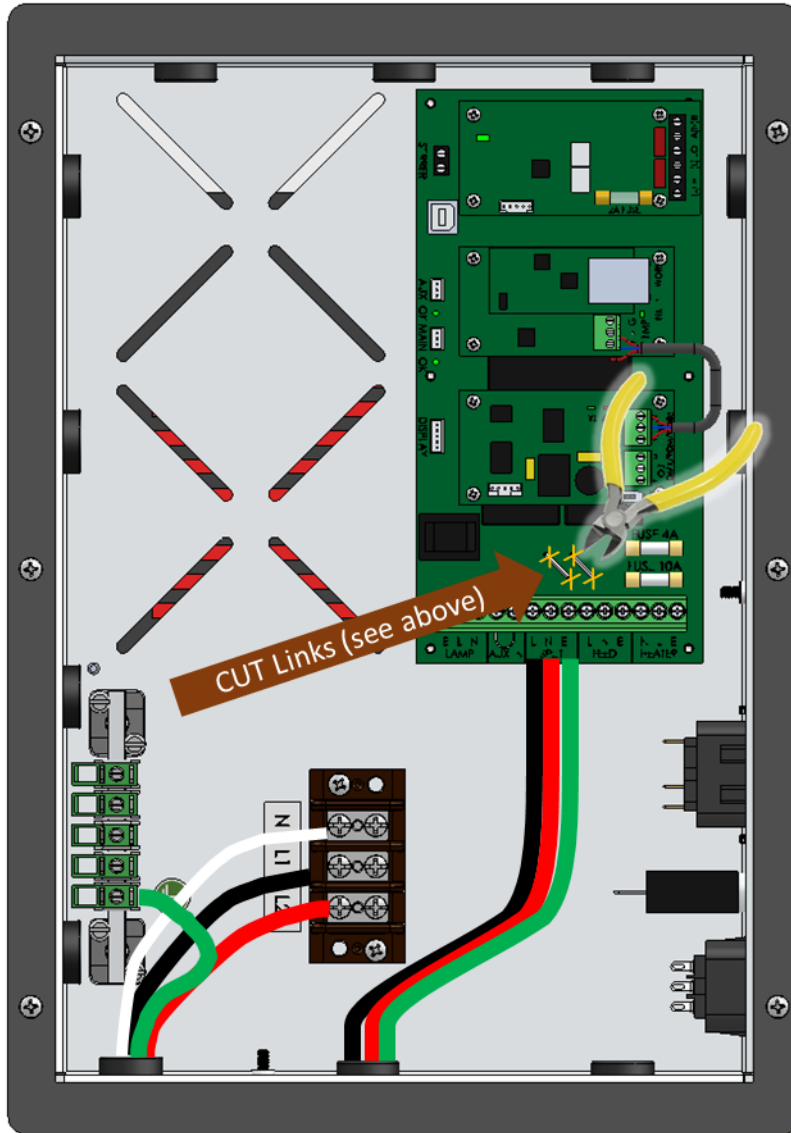

- | | |
|----------|--------------------------------|
| Hot | Ground |
| Hot | Hot |
| Ground | Hot |
| Neutral* | Projector Feed |
| | 200/208V Single-phase (2 hots) |
| | Current to suit projector |
- Enclosure Feed**
200/208V 15A Single-phase (2 hots)
* 10A Neutral for 120V Aux power

International, 230V Split Feed

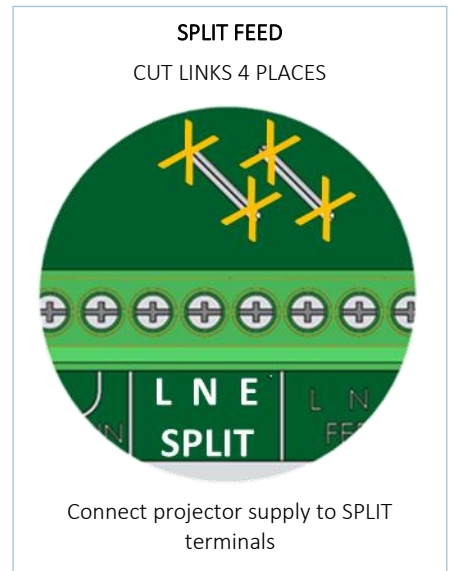
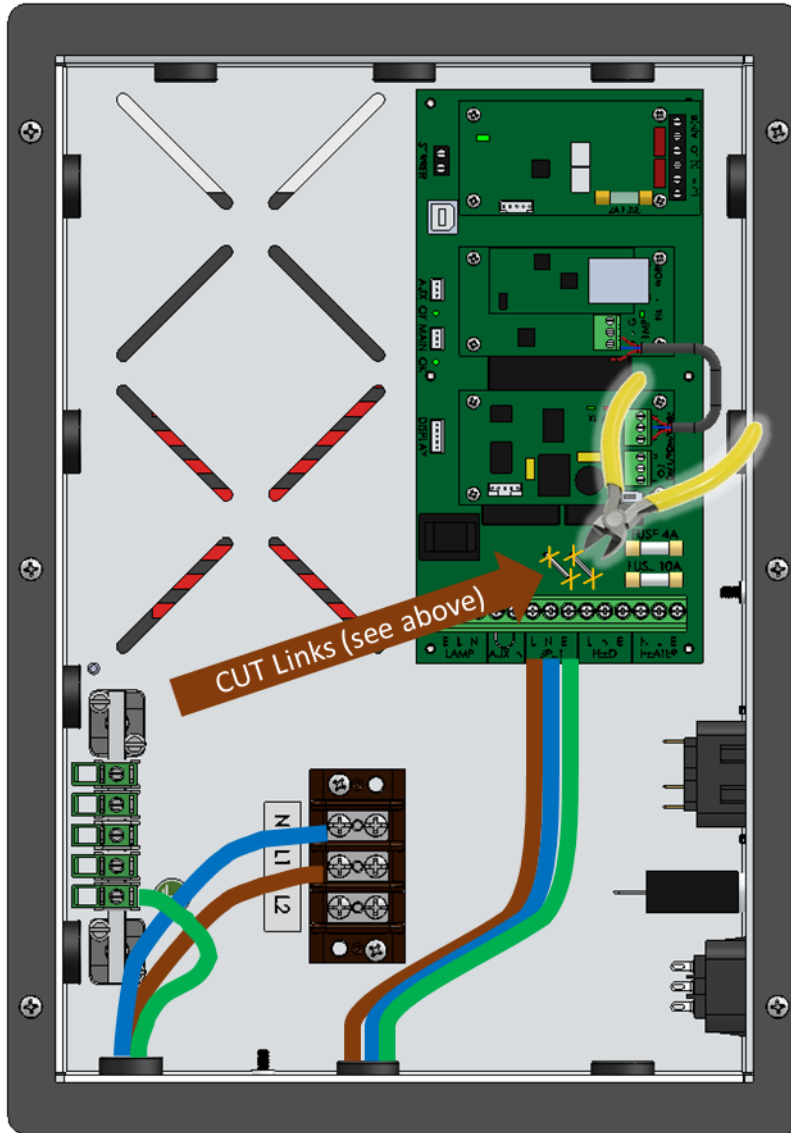

--- Earth
 --- Live
 --- Neutral
Enclosure Feed
 230VAC 15A Single-phase (LNE)
 (for clarity, internal wiring not shown)

--- Earth
 --- Neutral
 --- Live
Projector Feed
 230VAC Single-phase (LNE)
 Current to suit projector

Remote Monitoring Connections

Tempest G4 enclosures optionally support four types of remote monitoring:

1. Direct via Ethernet, using Tempest TEMP protocol (see Appendix – TEMP Protocol)
Requires 51.EN Ethernet board
2. Grouped via RS485, using an Ethernet board and Tempest TEMP protocol (see Appendix – TEMP Protocol)
Requires 51.EN Ethernet board in one enclosure
3. Direct via JESE Agent (see below)
Requires 51.D4.51 JESE Agent node
4. Grouped via RS485 and JESE Agent (see below)
Requires 51.D4.51 JESE Agent node in one enclosure
5. Grouped via RS485, using DMX/RDM – see next page

Find out more about Local and global monitoring via JESE Agent >>>

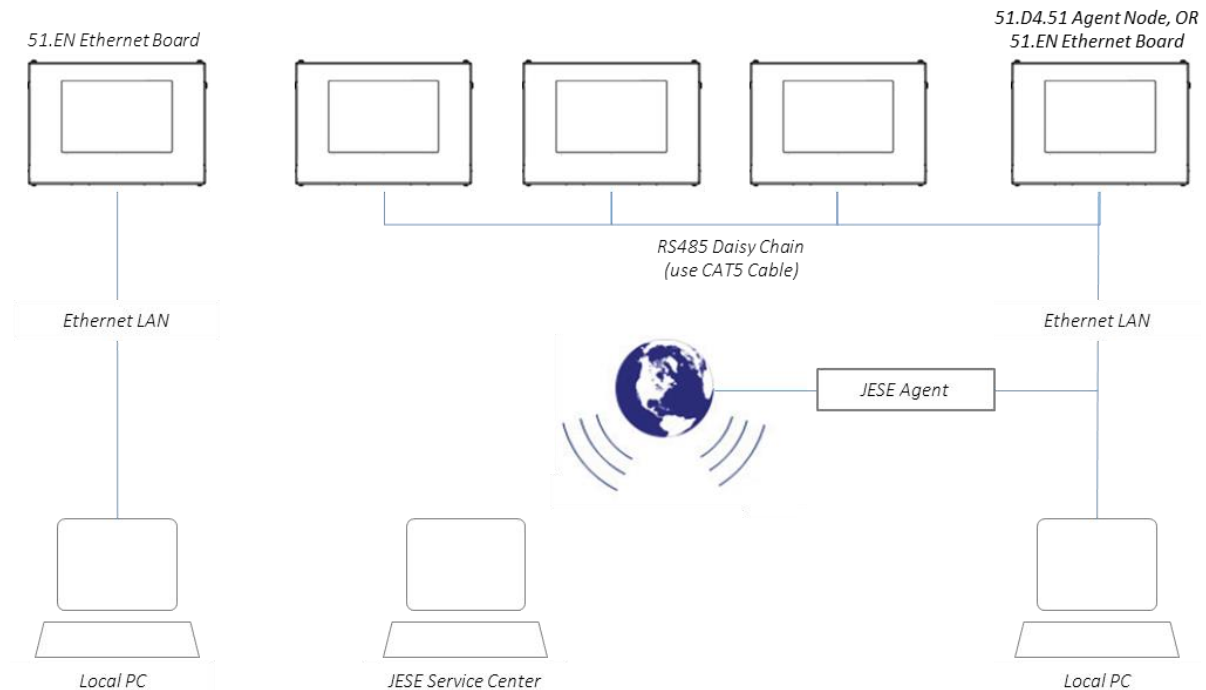

Note: Consult factory for JESE Agent Global monitoring service

RS485 (DMX/RDM) Cable Terminations

DECA System Control Board, with three typical Daughter Boards:

1. AC Fan Controller
2. Ethernet Bridge
3. RS485 Comms

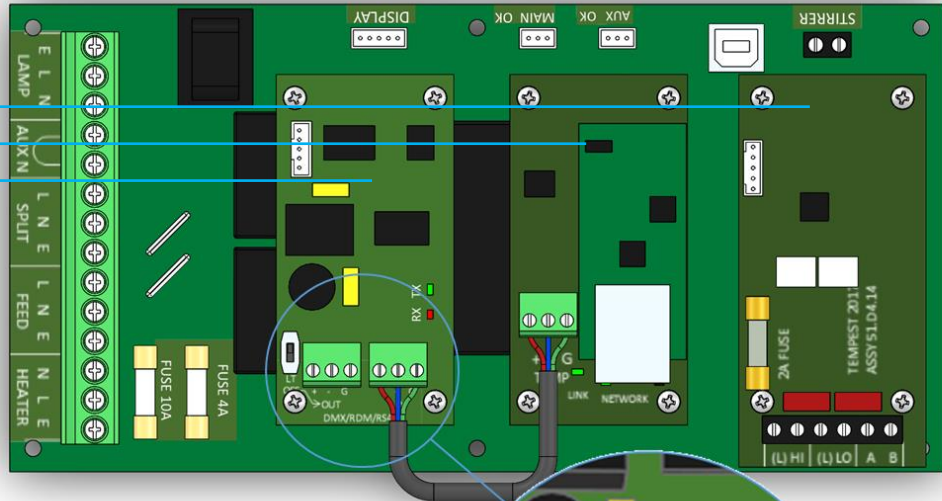

Loop a shielded twisted pair cable (eg Belden 9841, though many people now use a CAT5e cable) from the control/monitoring point, around all enclosures.

Maximum total cable length is 1,200M (4,000ft). For longer runs and wildly distributed systems, use a DMX/RDM splitter (make sure that it supports RDM) and multiple cable runs.

Use the termination switch to terminate each RS485 cable run at the last enclosure on each run.

RS485 Line Termination (LT) Switch:

TERMINATED



Data + Data - Common Data + Data - Common
DATA OUT DATA IN



Tempest recommends the JESE SH8 DMX/RDM Splitter for large or complex RS485 networks.

JESE RDM-TRI interface connects to a PC via USB to monitor and control a network of Tempest enclosures.
Tempest Item # 2000.195



Line Termination Switch Settings

1. DMX/RDM control over RS485:

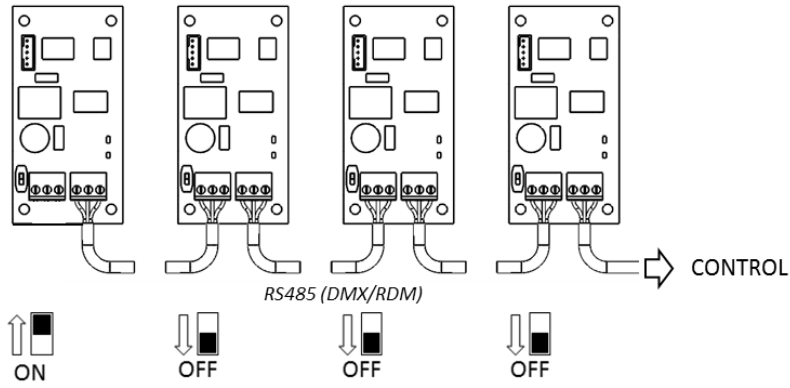

2. TEMP Control of an enclosure group via Ethernet

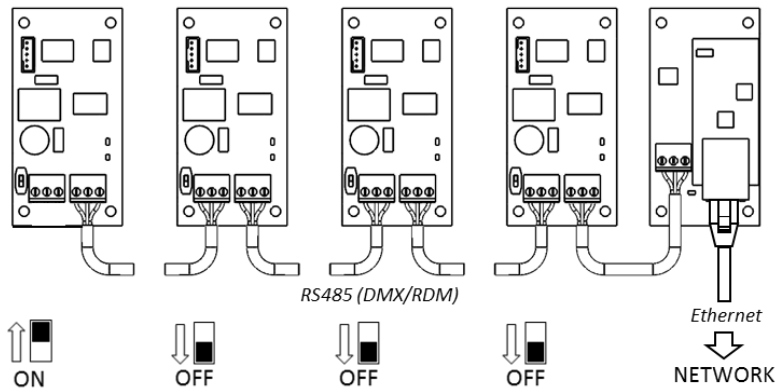

3. TEMP Control of a single enclosure via Ethernet

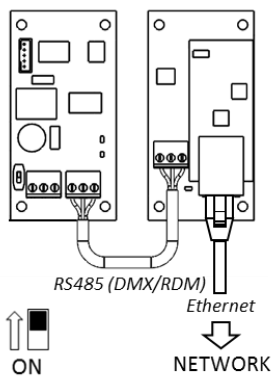

DEC4 Ethernet Adapter – 51.EN

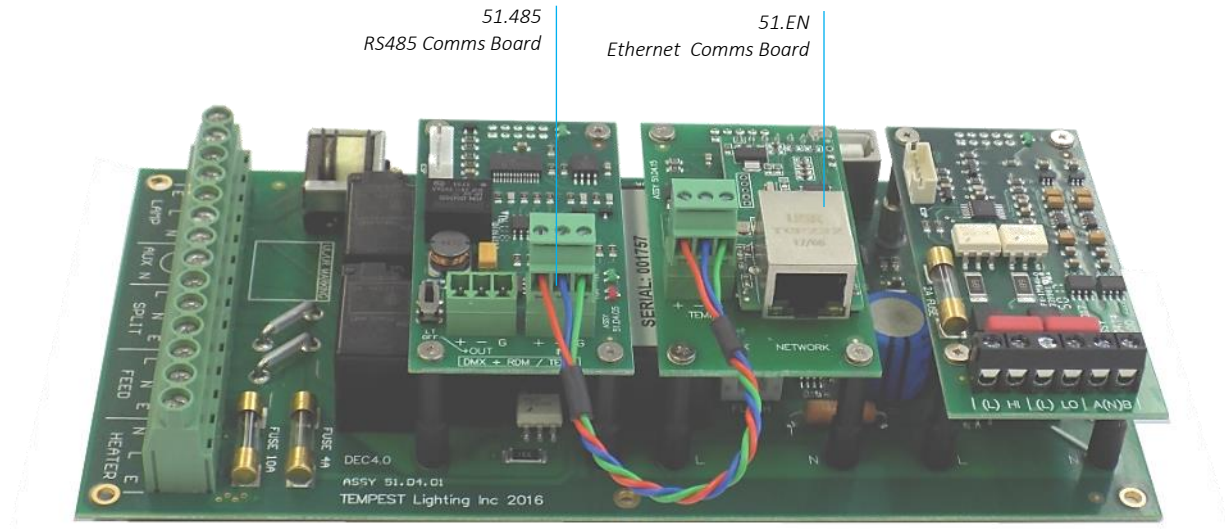

As a default, DEC4 communicates using DMX512 and RDM, over RS485.

With the addition of the 51.EN Ethernet board, any DEC4 – or any group of DEC4 boards connected using RS485 – may be connected to an Ethernet network – see above.

Default Configuration

The bridge module is supplied in DHCP TCP port server configuration, with all traffic on port 3308. These settings may be changed with a web browser on port 80 at the DHCP assigned address. Login to the home page using 'admin' for user name as password.

The bridges may be discovered with a UDP broadcast on port 1500 and a payload of

```
(Hex) 30 31 32 33 34 35 36 37 38 39 30 31 32 33 34 35 36 37 38 39
      30 31 32 33 34 35 36 37 38 39 30 31 32 33 34 35 36 37 38 39
```

The bridge will respond from its DHCP address

Additional Support

The network IP is developed by Jinan USR, more details and software configuration utilities may be found by visiting their web site at <https://www.usriot.com>

Tempest Equipment Management Protocol

TEMP allows you to access status information and set configuration values on DEC3.3 and DEC 4 enclosure controllers, using the 51.EN Ethernet Adapter, over an Ethernet network.

Download the Developer Guide at
www.tempest.biz/tech_support

IMPORTANT:

Tempest warrants that, if correctly implemented, TEMP will provide a reliable and accurate method of monitoring Tempest DEC3 and 4 controllers over an Ethernet network. However, the integrator is entirely responsible for the connection between the Ethernet Bridge and the network.



Projector Power Control using DMX512

The DEC4 controller includes a 30A 2-pole relay that protects the enclosed equipment in the event of a serious high temperature event by cutting off power. In 3-phase enclosures this is augmented by a 4-pole contactor.

You may use DMX512 (a popular entertainment industry protocol running on RS485, originally intended to control lighting system dimmers) to control power to the projector inside the enclosure. This is very useful in hot locations, where the projector may be stressed by being held in standby mode all day under hot sun. By powering the projector down it will tolerate much higher temperatures without harm.

Tempest recommends the JESE RDM-TRI interface to monitor enclosure status in any installation and control the enclosure power relay in smaller systems.

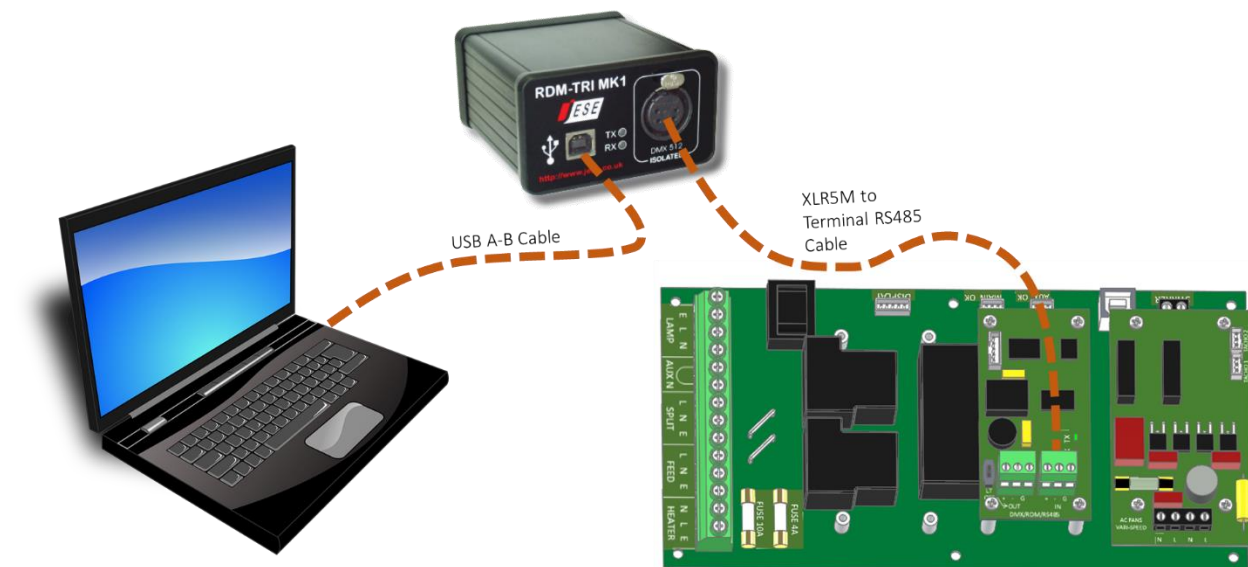
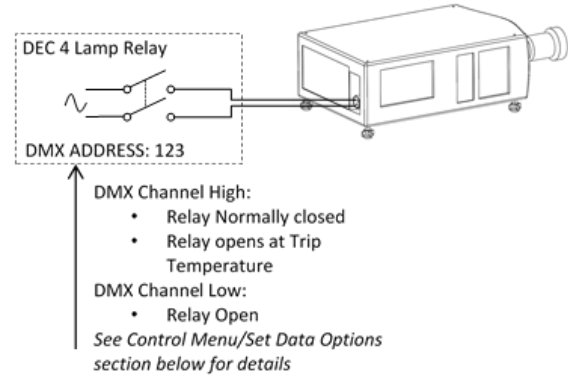

More complex installations are very likely to include some kind of show control system that will certainly include DMX control. This is the preferred method of controlling power to the projectors.

DMX/RDM Network, using JESE RDM-TRI

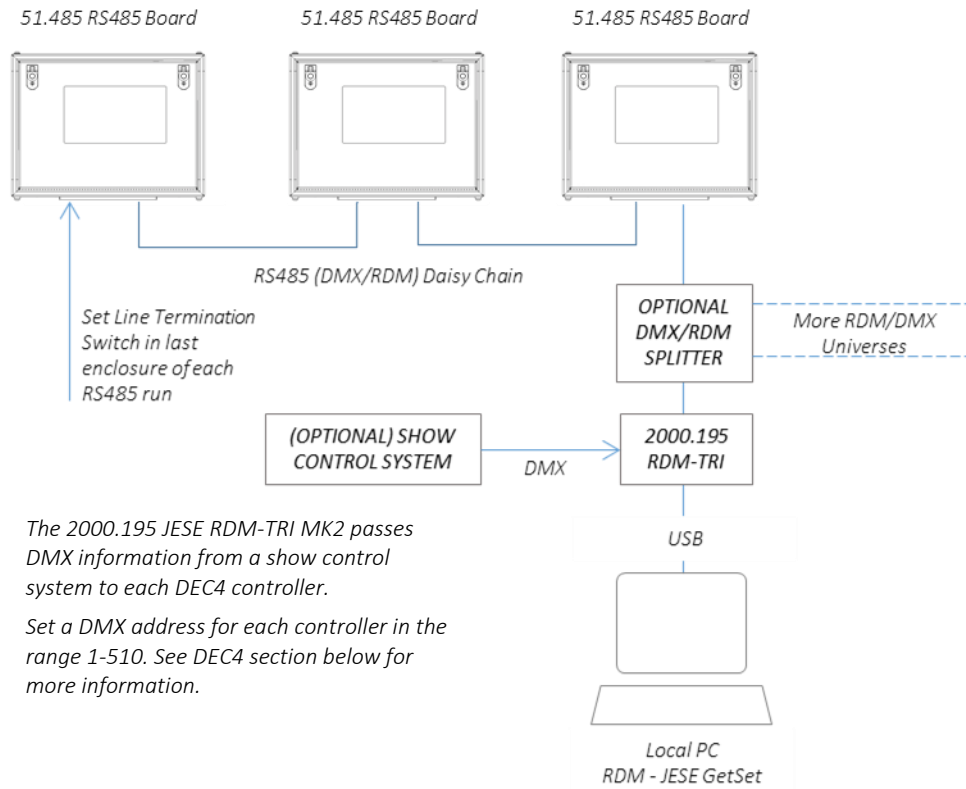

The 2000.195 JESE RDM-TRI MK2 passes DMX information from a show control system to each DEC4 controller.

Set a DMX address for each controller in the range 1-510. See DEC4 section below for more information.

Positive Pressure Fan Control Option

When the Positive Pressure (51.PP) option is ordered, the enclosure fan function is changed.

- Normally the enclosure fan(s) will run only when either the projector/luminaire lamp is on, or if the daytime temperature in the enclosure exceeds the DEC Upper Temperature setting. At all other times the fan is OFF.
- With the Positive Pressure option, when the fan would normally be off, it is instead powered via a capacitor that lowers the operating voltage so that the fan continues to run at a low level, maintaining positive pressure in the enclosure and preventing harmful contaminants from entering through the exhaust path.

Fan Control Board

Capacitor

Fan

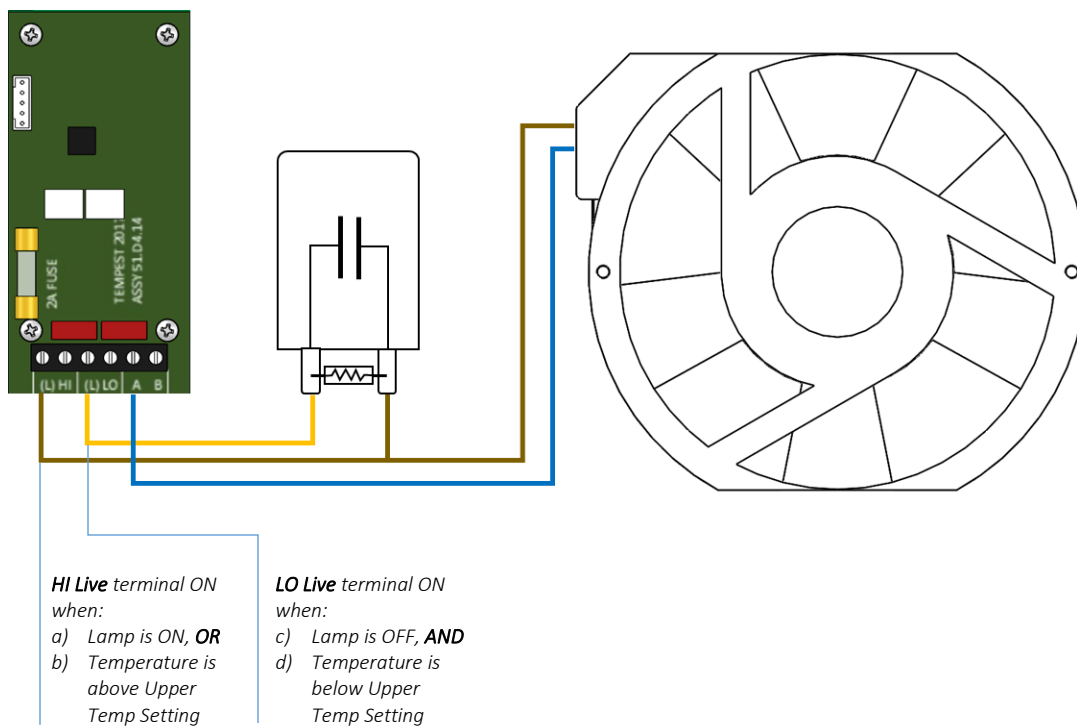

Digital Enclosure Control

DEC4™ – that’s Digital Enclosure Control, fourth Generation – is the brain of your Tempest enclosure. It will maintain the internal environment in a comfortable temperature and humidity range, and prevent condensation – the real killer of outdoor equipment. DEC4 monitors internal and external temperature, humidity and lamp current at all times, and uses this information to control the enclosure’s lamp relay, fan(s) and heater(s). It can report back over an RS485 network, using the RDM protocol (Remote Device Management), or connect to your TCP/IP network for remote monitoring and management using Tempest’s TEMP protocol.

Typical DEC4 configuration, with Motherboard, fan control board and RS485 comms board

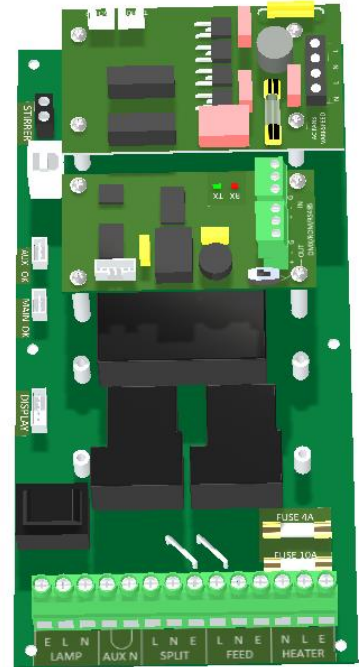

Schematic

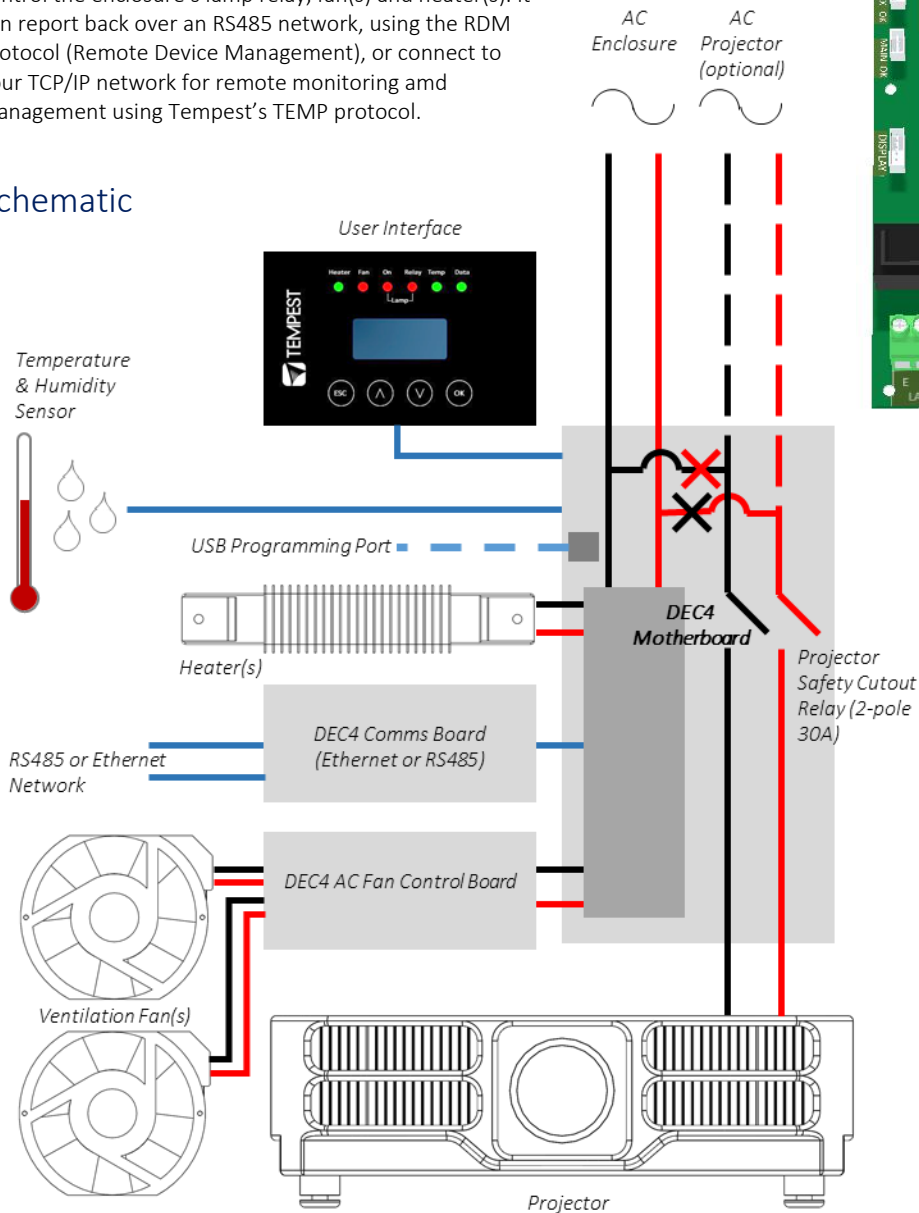

DEC4 Main Functions

Firmware Revision

This manual covers DEC4 Firmware revision 2.03.000 and higher.

To check the Firmware revision, on the User Interface menu, go to Status Display/Firmware.

1. Sense current to projector (lamp on/off)
2. Record lamp hours
3. Monitor temperature and relative humidity inside Enclosure
4. Monitor temperature outside enclosure
5. Maintain internal temperature at safe operating level
6. Maintain relative humidity within safe limits to prevent condensation
7. Isolate projector in case of unsafe temperature
8. Report status over RS485, RDM, TCP/IP
9. Maintain positive pressure (optional) 24/7 to prevent ingress of salt air and other contaminants through the exhaust path
10. Circulates air internally to prevent hot and cold spots when projector is idle

DEC 3.3's patented Goldilocks™ algorithm uses a combination of sensors, heaters and fans to maintain a safe operating temperature and a safe relative humidity level that will not allow condensation to take place.

As air is heated it is able to support more moisture without condensing, so Goldilocks uses heat to raise the air temperature inside the enclosure in the event that relative humidity approaches dewpoint.

DEC4 constantly monitors the following parameters:

- Projector/Luminaire current
- Line Voltage
- External Temperature
- Internal Temperature
- Internal Relative Humidity

Factory Settings – Data Modes

In most applications, DEC4 will operate correctly with its factory default settings, in Basic operating mode.

You do not need to do anything. Please skip to the next section.

- Standard default temperature and humidity settings
- DMX, RDM and Remote Monitoring disabled
- Best for standalone operation

If your needs are more complex, read on.



Hardware Indicators & Fuses

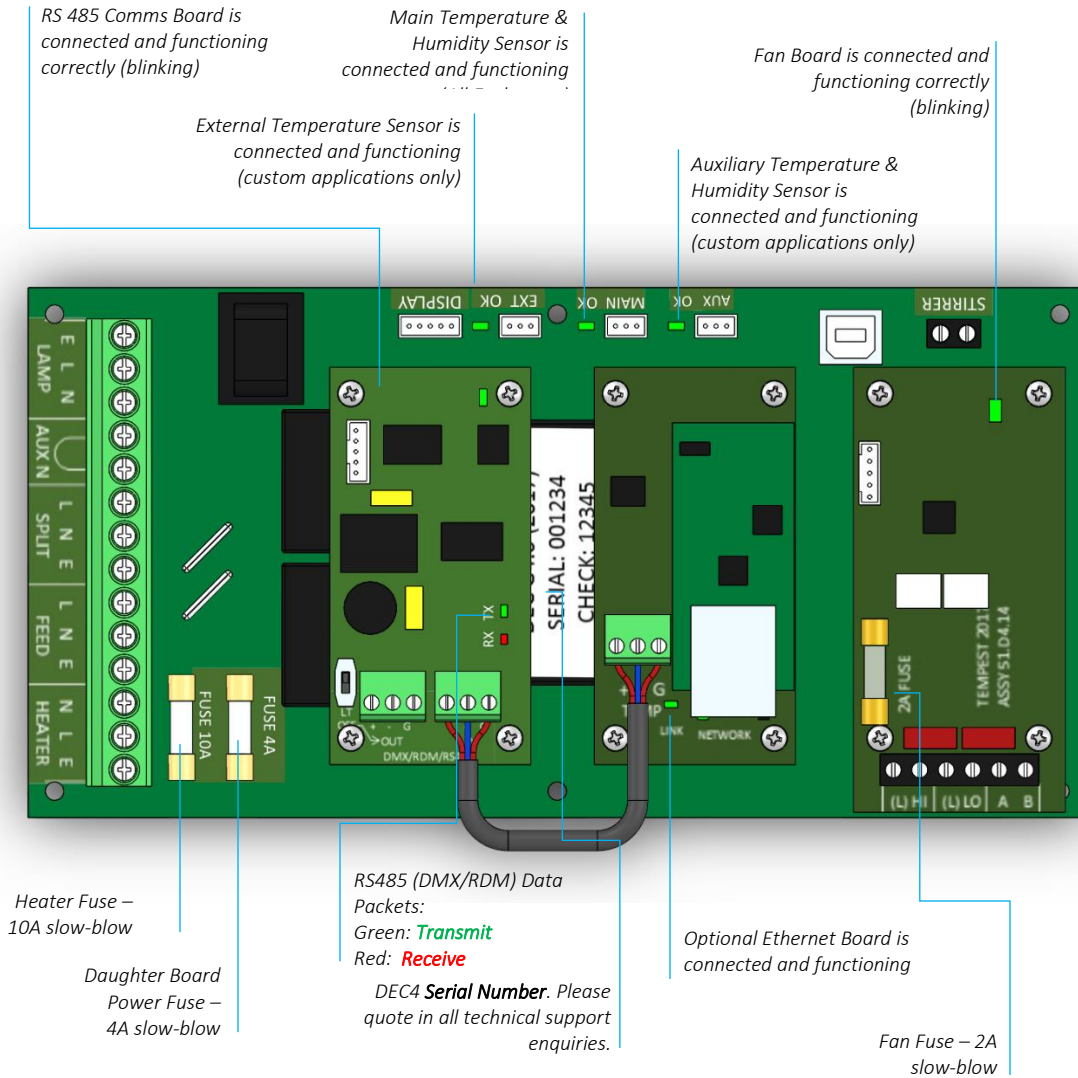

Operating Modes

RDM Only Monitor (Factory Default)

- Supports RDM monitoring over RS485 if present
- Supports TEMP monitoring if present
- RDM Status Reporting over RS485
- RDM Configuration – settings may be changed remotely or at the enclosure user interface.
- No DMX control

RDM+DMX Control

- Enclosure functions as a 1-channel DMX device, with remote control of the lamp relay
 - DMX level > 75% enables normal relay operation (normally ON)
 - DMX level < 25% disables normal relay operation (relay turns OFF)
 - This allows you to force a hard reset of the lamp relay in the event of a projector malfunction
- RDM Status Reporting over RS485
- RDM Configuration – settings may be changed remotely or at the enclosure user interface.
- Control mode is recommended for show control applications, but can be risky in live show operation, since the DMX slot used for the enclosure MUST be kept high to prevent the lamp relay from opening.

RDM+DMX Service

For trained service personnel only

- Normal operation is suspended and the enclosure functions as a 3-channel DMX device:
 - Lamp Relay (Slot 1)
 - Fans (Slot 2)
 - Heater (Slot 3)
- RDM Status Reporting over RS485
- RDM Configuration – settings may be changed remotely or at the enclosure user interface.
- ***Service mode is ONLY for troubleshooting – DO NOT use Service mode for normal operation.***

DEC4 Control Parameters

Temperature and Humidity Ranges

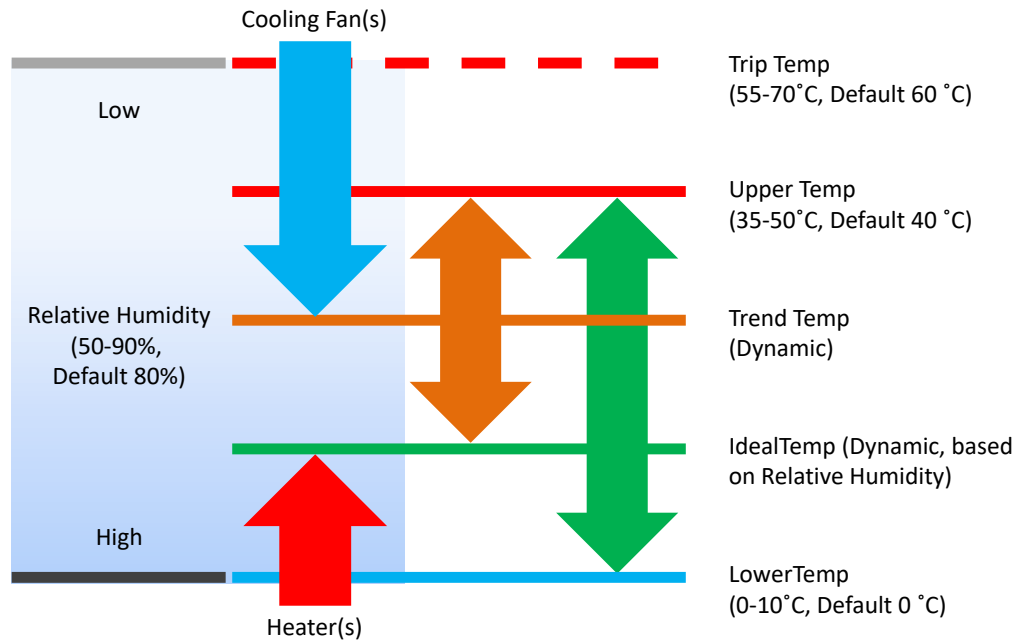

Notes:

- 1 In moving light enclosures the temperature sensor is located in the exhaust airflow. Temperatures shown may be higher than those around the projector.
- 2 We recommend using the factory default settings for several weeks or months before making any changes. In most cases they will not be necessary.

Control Interface

LED Indicators

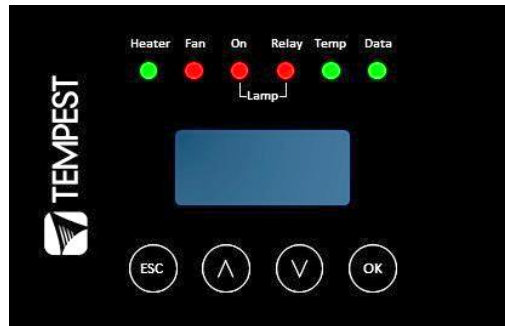

| | | |
|-------------------|------------------|--|
| Heater | ON (Green) | Heater is ON, to maintain lower temperature level or to prevent condensation |
| | ON (Amber) | Enclosure is temporarily outside the Goldilocks zone, and DEC is working to restore it |
| Fan | ON (Green) | Lamp is ON, or Temperature is HIGH and fan is cooling enclosure. Short burst when lamp off indicates fan moving air to stabilize temp/humidity. <i>NOTE: Fan LED will not light if no fan is detected</i> |
| | Lamp On | Current sensing shows lamp is ON Lamp hour counter is running |
| Lamp Relay | OFF | Current sensing shows lamp is OFF Lamp hour counter is not running |
| | ON (Green) | Lamp relay is closed (normal) Projector power receptacle is energized |
| Temp | ON (Red) | Lamp relay is open due to over-temperature event. Projector power receptacle is isolated. |
| | FLASHING (Green) | Temperature is below lower temp setting |
| | ON (Green) | Temperature is in normal range |
| | ON (Amber) | Humidity is above target limit |
| | ON (Red) | Temperature is above top setting |
| Data | FLASHING (Red) | Temperature is above Trip level Projector power is isolated |
| | OFF | Data not used in present Mode. OR DEC4 is in RDM + DMX Control Mode and no valid data packet has been detected. |
| | ON (GREEN) | Good data packet received. |
| | ON (RED) | RDM + DMX Control Mode: Data Fail. A previously good data signal has failed. |

User Interface LCD Display

The display on the Control display provides additional status information, depending on the operating mode:

RDM Only Monitor Mode

| | | |
|-------|-----|--|
| 28 °C | 47% | <i>internal temperature, relative humidity line voltage, lamp status</i> |
| 209V | OFF | |

RDM+DMX Control Mode RDM+DMX Service Mode

| | | |
|-------|-----|--|
| 28 °C | 47% | <i>internal temperature, relative humidity line voltage, lamp status</i> |
| 209V | OFF | |

Alternating with:

| | |
|----------|---|
| DMX: 001 | <i>DMX Start Address DMX Status</i> |
| No DMX | |

(Alternating DMX Display requires a DMX signal to be present)

Control Interface Operation

The Control Interface is normally LOCKED.

- To UNLOCK, hold **ESC** and **OK** together for **5 seconds**.
- You are now in the CONTROL MENU
- Use **↑↓** to scroll up and down the menu.
- Press **OK** to enter a menu item
- Use **↑↓** to set the item parameter, or to scroll to the next menu level.
- Use **ESC** to go BACK, or **OK** to confirm settings (**↵**).
- To exit and LOCK, hold **ESC** for 5 seconds.

Menu will time out and the display will lock after ten minutes.

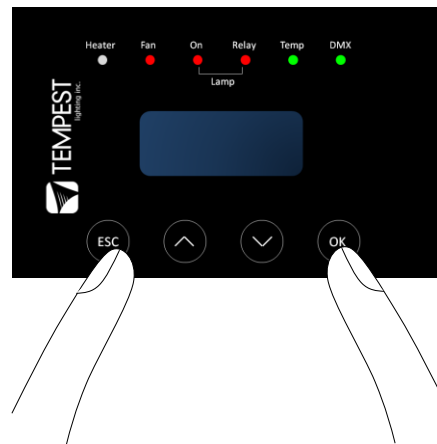

Control Menu

Set Data Options

SET DATA MODE

From the Front Panel, this menu item allows the user to check (and if necessary change) the Data mode.

| | | |
|------------------|---------|--|
| RDM Only Monitor | DEFAULT | Supports RDM or TEMP if connected. No DMX Control. |
| RDM+DMX Service | | Service mode – 3 DMX slots, starting with the DMX address set <i>Important: Please ensure that DEC4 is NOT left in Service Mode.</i> |
| RDM+DMX Control | | DMX (set 1 address for lamp relay) plus RDM |

SET DATA ADDRESS (in RDM Only Monitor, RDM+DMX Service or RDM+DMX Control Service modes)

Select a DMX starting address in the range 001 to 510

1 – Lamp Relay

In Service Mode an addition two slots are available

2 – Fan Duty Control

3 – Heater Duty Control

Note that the DMX control is designed using a SAFETY pile-on Logic. So the DMX input can only override automatic settings within safe limits.

SET DATA CURVE

DMX Curves affect the way the fixture relay is controlled in RDM+DMX Control Mode.

DMX levels are shown as %.

Response Curve 1 (default)

DMX level 0-25 Relay disabled (open)

DMX level 26-75 No change to relay status

DMX level 76-100 Relay enabled (normally closed)

Response Curve 2

DMX level 0-19 No change to relay status

DMX level 20-40 Relay disabled (open)

DMX level 41-59 No change to relay status

DMX level 60-80 Relay enabled (normally closed)

DMX level 81-100 No change to relay status

SET DATA RESPONSE

DMX Response sets a delay time before DMX Control Mode settings are acted on. Setting a response delay of a few seconds would prevent unintended fixture relay state changes in the event of a short accidental change in DMX level.

NOTE: from firmware revision 0.00.100, DEC holds last valid DMX level if DMX is interrupted.

Response Delay Values are:

No Delay (default), 1, 2, 5, 10, 15, 20, 30, 60 seconds.

Set Temp Units

Choose to display temperature values in Celsius or Fahrenheit (default Celsius)

Note that temperature settings must be entered in Celsius.

Set Temp Ranges

Set three temperature trigger points for Bottom, Top and Trip temperatures, in °C.

SET TEMP LOWER (minimum temperature to be maintained)

(default 10°C, permissible range 0-10°C).

SET TEMP UPPER (maximum desired daytime temperature)

(default 45°C, permissible range 35-50°C).

SET TEMP TRIP (temperature at which load will be isolated – see note)

(default 60°C, permissible range 55-70°C).

Note: A thermal emergency is when enclosure ventilation fails with the lamp on, in which case the temperature will rise very quickly. To avoid nuisance tripping we recommend setting a higher Trip temperature, 60°C or above.

Set Max Humidity

Sets highest desired Relative Humidity: Default 85%, permissible range 80-90%.

Note that, when the projector/luminaire lamp is OFF, the enclosure heaters will switch on to raise the temperature and lower the risk of condensation. We recommend setting the highest Max Humidity that works in your location, to avoid unnecessary heater use.

Set Lamp On Point

The lamp current at which DEC detects the projector/luminaire lamp is running. Default is 1 Amp, which allows for most equipment fans and power supplies to run without changing the air in the enclosure. Lamp on point may be set in 0.1 Amp increments between 0.2 Amps and 2.0 Amps.

If the enclosure fans never turn off, the Lamp On point is probably set below the standby current draw of the projector/luminaire. Check the standby current draw on the display and set the Lamp on Current higher.

Reset Lamp Hours

Reset each time you change the lamp in the projector.

Make this a part of your maintenance instructions.

Set Fan Function

SET FAN TEST

To test the enclosure fan(s), press [OK]

The enclosure fan will run

The Display Fan LED lights green

DEC Beeps

To stop the fan test, press [ESC]

Status Display

View current status information, using the arrow keys to scroll through:

- a) Humidity – relative humidity in %
- b) Internal temperature, in degrees C or F
- c) External Temperature (custom enclosures with external temperature sensors only)
- d) PCB temperature (this will usually be significantly higher than air temperature)
- e) Voltage – line Voltage reaching the DEC
- f) Current being drawn by projector/light, in Amps
- g) Lamp Hours elapsed since last reset
- h) Firmware version
- i) UID – unique system ID number

Safe Mode

In certain circumstances, the DEC User Interface may display the message SAFE MODE. This can happen if the Humidity sensor stops reporting, or reports an extreme value, indicating the probability of a sensor error. This situation may arise either because of a faulty sensor* or in conditions of extremely high absolute humidity.



In SAFE MODE, the normal Goldilocks operation is temporarily suspended, and the enclosure works to return the internal environment to a condition from which normal operation may be resumed.

SAFE MODE is SAFE! It indicates that attention may be needed, but not that your equipment is at risk.

** Some sensors shipped before mid-2017 have had a limited operational life in harsher conditions. Tempest has since developed a new class of capacitive sensor that is far more resilient, especially in demanding conditions.*

The new class of sensors (MG Type) have either:

- a) A piece of green tape on the sensor cable

And/or

- b) TEMPEST logo on the plastic sensor case

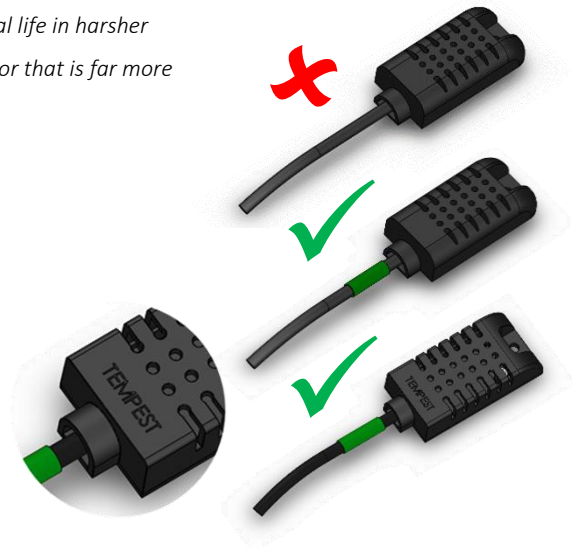

Safe Mode – What to do:

If you see **SAFE MODE** on your User Interface Display:

1. Check the temperature/humidity sensor:
 - a. If it does NOT have either a Tempest logo or a piece of green tape on the cable, contact Tempest for a free-of-charge replacement. If you have more than one enclosure, we suggest replacing the sensors on ALL your enclosures.
2. If the sensor has either a Tempest logo or a piece of green tape on the cable, then:

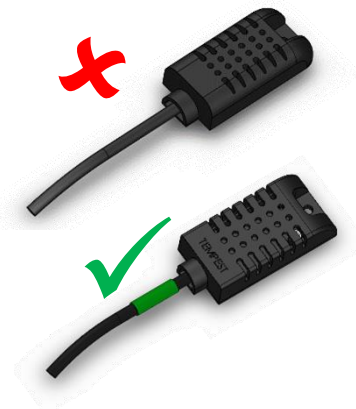

- a. Check that the sensor cable is not damaged and that it is plugged in to the header on the DEC Mother board labeled MAIN
- b. Check the actual climate conditions – could the absolute humidity be close to 100%? If it is, SAFE MODE is operating correctly, and all is well.



DEC4 Firmware Updates

From time to time Tempest may introduce new DEC4 firmware for feature enhancements and bug fixes. Please note that the main System Control Board (SCB) and the various optional daughter boards each have their own firmware, and it will be good practice to update all firmware in an enclosure for optimal performance and interoperability.

- System Control Board firmware may be updated DIRECTLY using JESE JUST software and a USB cable, or INDIRECTLY, over an RDM network, using JESE GetSet software and a JESE RDM-TRI interface.
- Fan board firmware is extremely simple and is unlikely to require updating.
- RS485 Board (51.485) firmware may be updated over an RDM network, using JESE GetSet software and a JESE RDM-TRI interface.

All required files are available for download at <http://www.tempest.biz/tech-support.php?lang=en>

Indirect Firmware Updates

Requirements

Windows Laptop / PC, Windows XP through Windows 10

A JESE RDM-TRI or RDM-TXI interface and USB connection (available from Tempest).

An installed version of the JESE GetSet RDM configuration utility.

A copy of the firmware file(s) to upload, available for download from www.tempest.biz/tech_support.

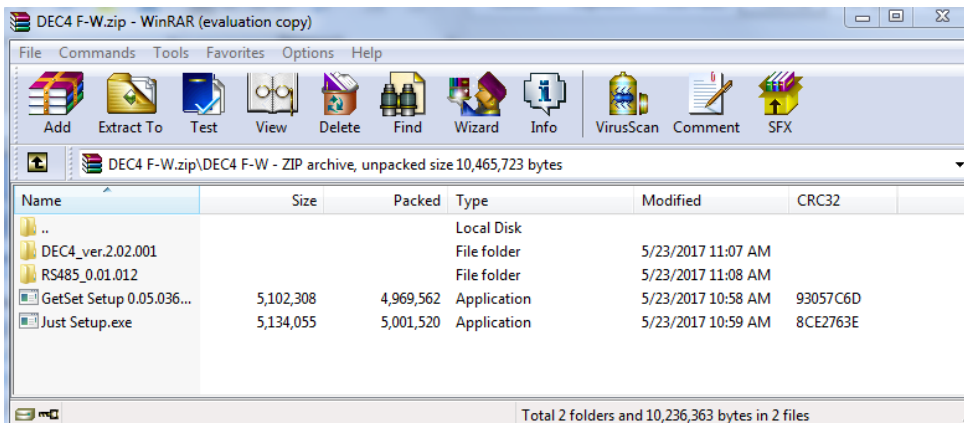

Powered Target DEC4 with 51.485 RS485 communication interface card.

Installation Procedure

1. If not already installed, install a copy of GetSet. *To ensure that the correct USB drivers are loaded, the software should be installed and the PC/Laptop re-started before connection to an RDM-TRI.*

2. If using an Asian character set, go to control panel and select Region and Language. Ensure input locale for non Unicode programs is set to a non Asian language

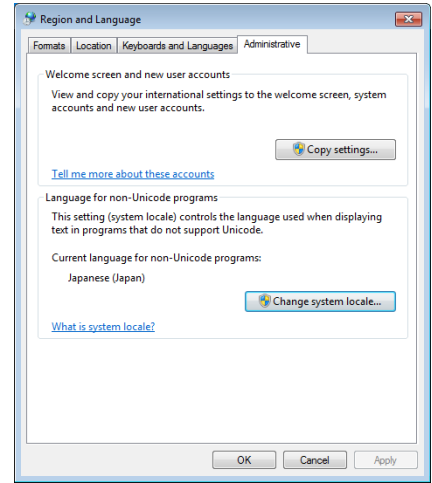

3. Plug your RDM-TRI in to your PC and connect to the RS485 connection on the DEC4 communications board with the fly lead, as shown below.

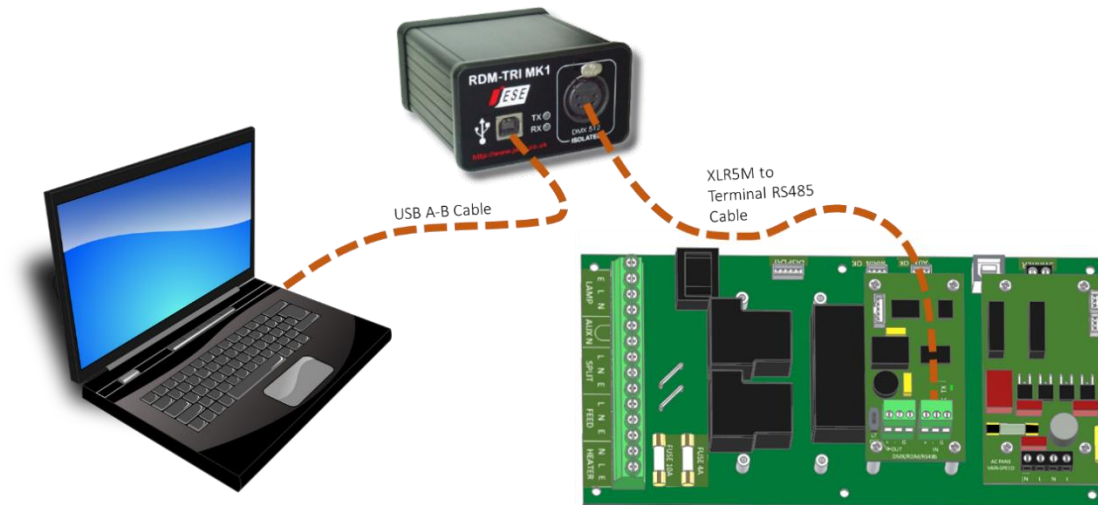

4. Power up the target SCB, ideally with mains power, or alternatively, with a USB power adaptor connected to the USB Port on the SCB.

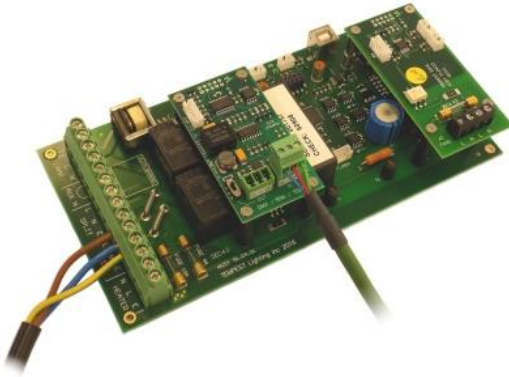

5. On older revisions of DEC Firmware, if the elected DEC 'DATA MODE' is set to 'RS485 TEMP', select 'RDM MONITOR' mode using the DEC user display. On more recent revisions of Firmware, the appropriate mode will be automatically selected.
6. Open the GetSet application, connect to the RDM-TRI and discover the DEC. To run discovery, click the Icon indicated below
7. Right click on the highlighted item in the list view and select 'Reprogram' from the popup menu. This will open the firmware upload tool.

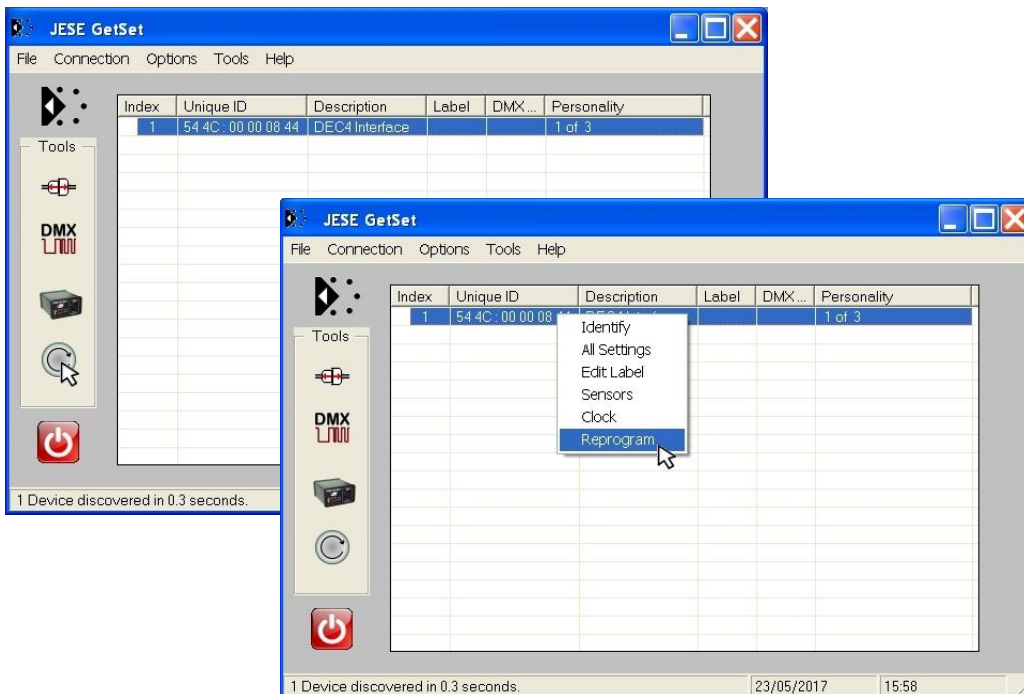

- In the Firmware upload handler, search for a file to upload by clicking the file icon. Find and select the file to load and click the Open button.

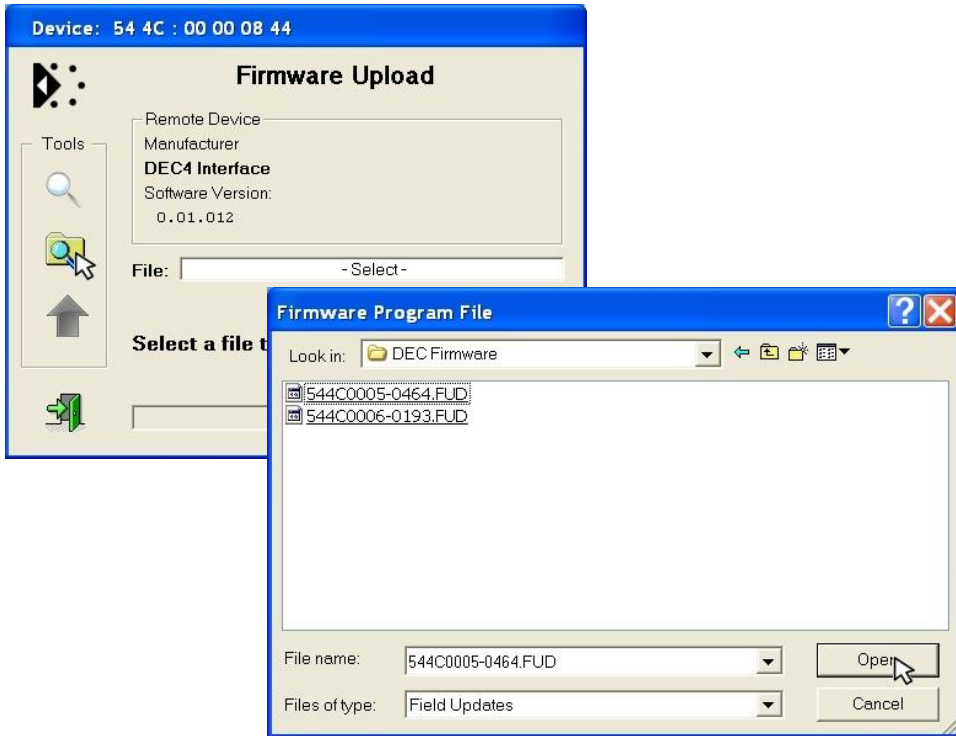

- On returning to the File upload tool window, select the green upload arrow to initiate the upload process. The upload will start.

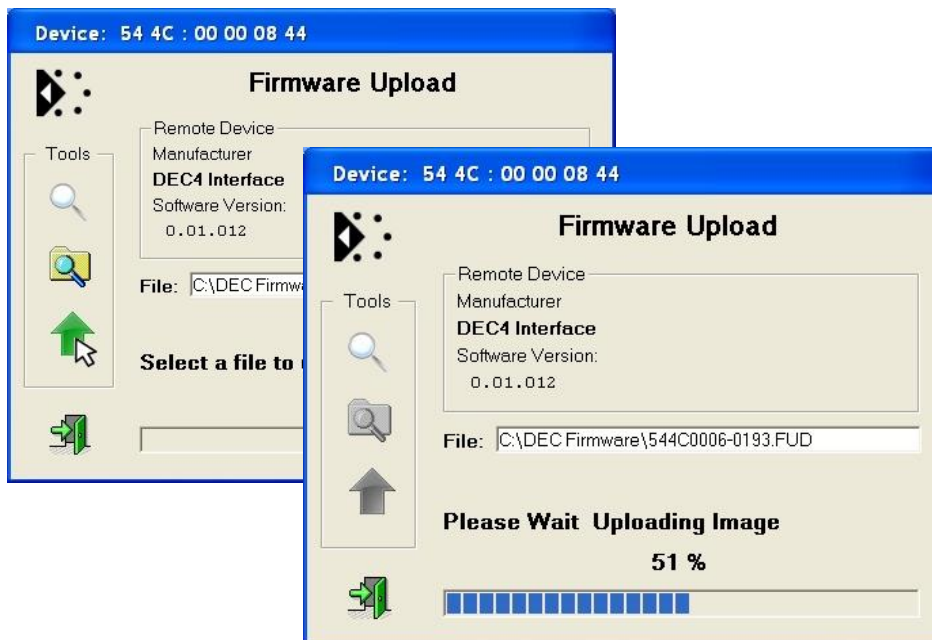

10. On successful completion of upload and restart, the firmware upload is complete.

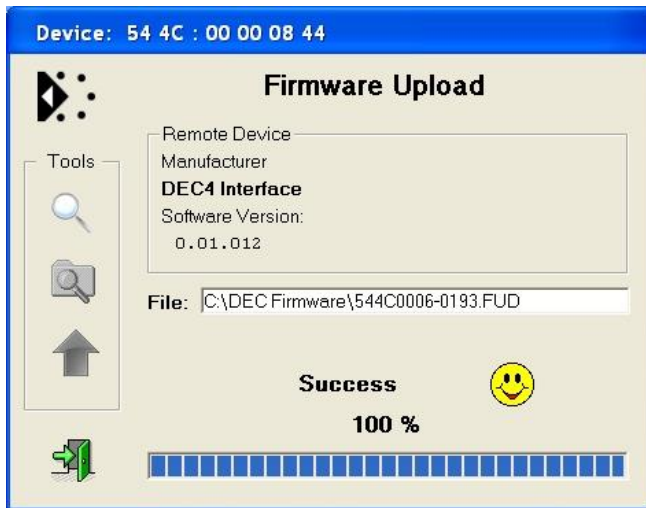

Repeat from stage 8 to 11 for each additional file to upload.

On completion of the upload, dismiss the upload window and return to the main window.

Close the application and disconnect the USB Cable from the SCB

Important:

If the Tempest enclosures are connected to an RDM interface or controller, set the DATA MODE for each enclosure as follows:

- RDM MONITOR ONLY** To view status information over RDM
- RDM + CONTROL** To monitor and over RDM and control the Lamp/Projector relays via DMX

If the enclosures are connected to an Ethernet network for monitoring using TEMP (Tempest Equipment Management Protocol) then the appropriate mode

Mounting the Projector

Important: Check Lamp-on Current

When the projector is installed and connected, check the current displayed on the User Interface, with the projector lamp(s) **OFF**.

If the current is 1.0A or higher, set the Lamp On Current to a setting higher than the actual displayed.

Example:

Standby Current = 1.4A

Set Lamp-On Current to 1.7A

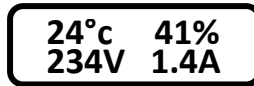

If the Lamp-on current is set lower than the projector's actual standby current, the DEC will think the projector lamp is always on. The fan(s) will never turn off, and the enclosure will never enter Goldilocks mode to protect your equipment from cold or condensation.

See Control Menu/Set Lamp-On Point above.

Projector Slide Configuration

Cyclone's projector tray will have been factory installed to your specification, sliding either left or right.

The Tray Assembly may be quite easily reversed on site if your plans change.

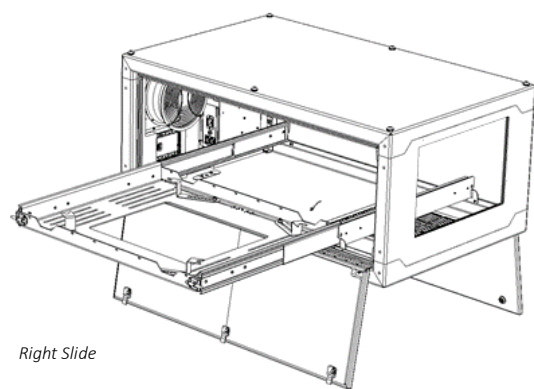
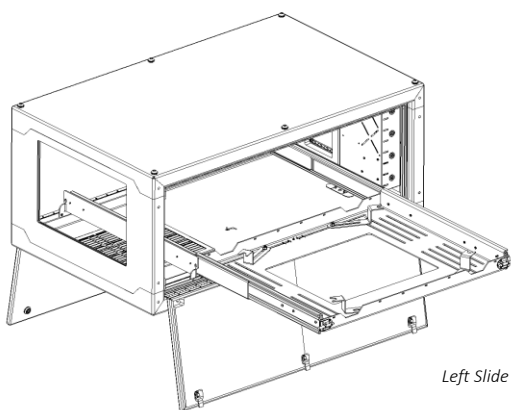

Changing the Projector Slide Direction

1. Close the projector slide, and secure the two slide bolts
2. Remove the eight M5 flathead slide beam screws
3. Lift the Tray assembly and rotate 180 degrees
4. Replace the eight M5 flathead slide beam screws.

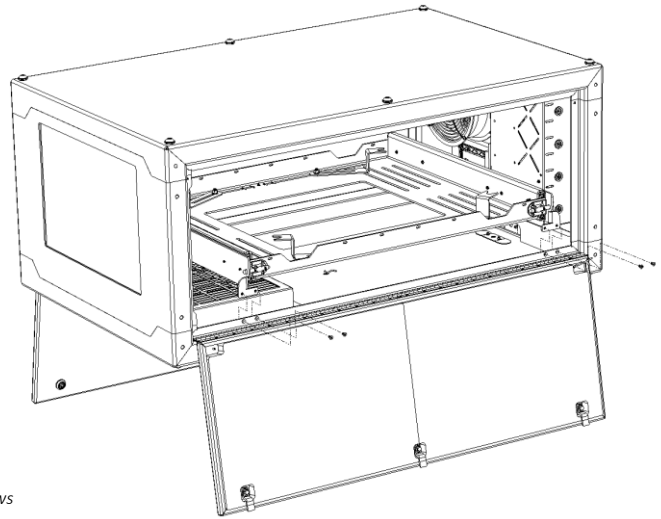
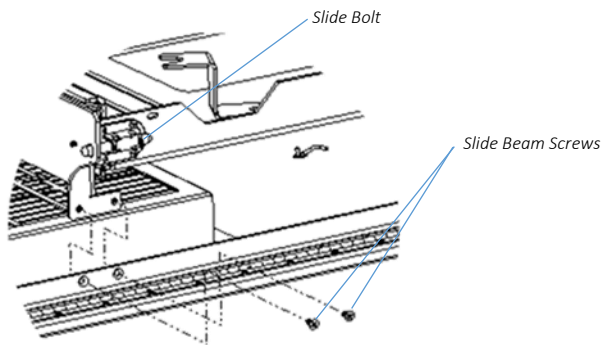

Securing the Projector (Landscape)

1. Slide the projector tray out and set the projector in place
2. Align the projector
3. Loosen the four projector clamp nuts
4. Slide the projector clamps to secure each of the projector feet (with some projector types you may need to raise the projector slightly)
5. Tighten the projector clamp nuts

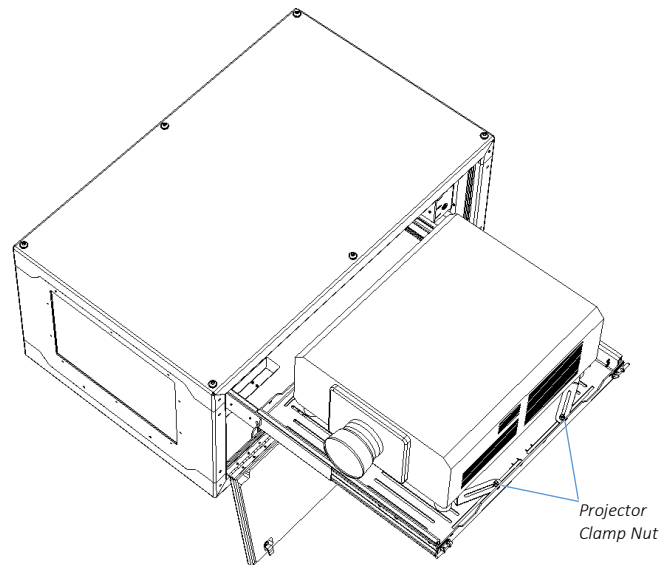
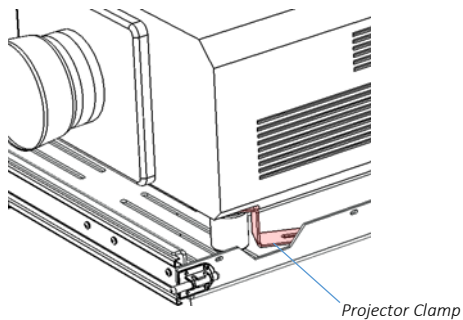

Portrait Projector Mounts

Portrait mounts vary by projector, but fall mainly into two categories:

Corner Mount – for projectors with threaded rigging points at each corner (includes many Christie models):

1. Remove the projector feet
2. Remove the Portrait Mount assemblies from the projector tray
3. Set the projector upside-down on a flat surface and attach the portrait mount assemblies
4. Flip the projector over and set on the sliding projector tray
5. Adjust projector position and tighten all projector mount hardware.

Note:

- a) *Adjust projector angle by using the holes in the triangular projector mounting plates. Each hole location corresponds to a tilt angle of approximately 1°.*
- b) *For projectors with side air inlets, make sure inlets are on the bottom.*

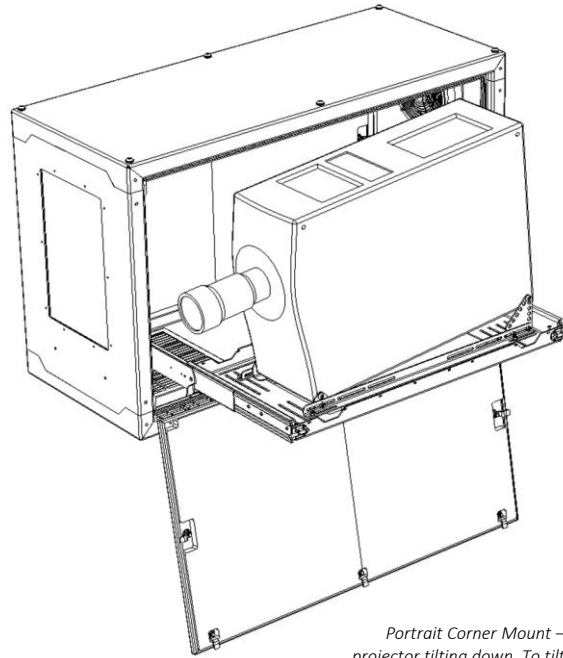

Portrait Corner Mount – projector tilting down. To tilt the beam up, simply assemble the mount with the triangular mounting plates at the front.

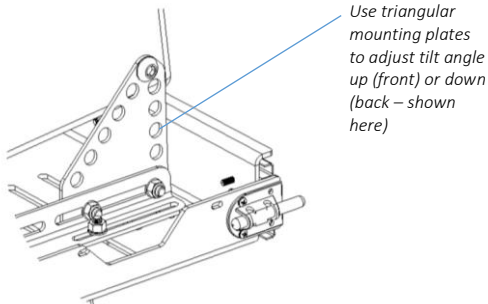

Use triangular mounting plates to adjust tilt angle up (front) or down (back – shown here)

Side Mount – most other projector types:

1. Remove projector feet
2. Use cap screws (bolts) with the same thread type as the projector feet to attach the projector to the L-brackets supplied.
3. Adjust up or down tilt angle by using L-bracket holes of different heights
4. Align projector
5. Tighten all mounting hardware

Notes:

- a) *the L-brackets may be installed facing left or right.*
- b) *For projectors with side air inlets, make sure inlets are on the bottom.*

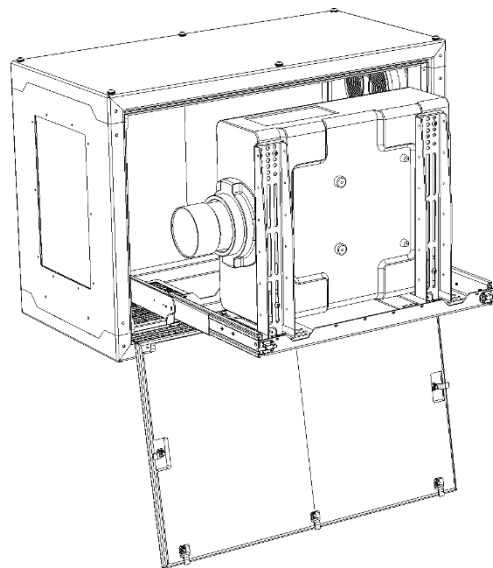

Remove projector feet and use screws with the same thread (usually M10 or M12) to mount projector to L-Brackets

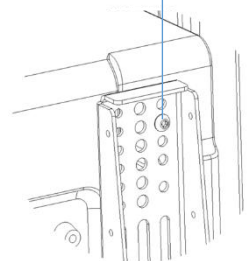

Connect Projector and Aux Equipment

- (1) Connect the projector power cable to the projector power outlet on the inside of the control box
- (2) Check to make sure that the power cable does not snag when pulling the projector tray in and out of the enclosure.
- (3) Connect all signal cables and test projector
- (4) Install any auxiliary equipment – there is usually plenty of room under the projector tray
- (5) Connect aux equipment power supplies to one of the C13 outlets on the DEC box. Use the supplied rewirable C14 plugs if necessary.

YOU **MUST** CONNECT THE PROJECTOR TO THE PROJECTOR OUTLET. IF THE PROJECTOR FEED BYPASSES THE DEC CONTROLLER, THE VENTILATION SYSTEM WILL NOT WORK AND THE PROJECTOR WILL OVERHEAT.

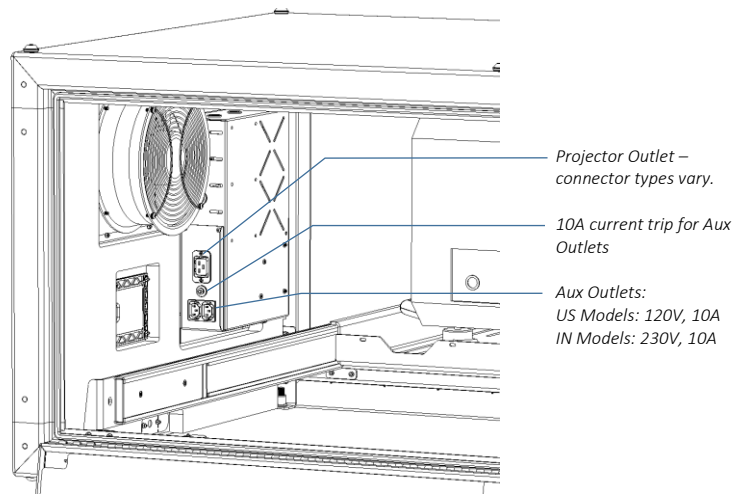

Projector-specific Mounting

All Cyclone enclosures are projector specific. Some projectors require special mounts and/or exhaust baffles. *Be sure to check for your projector in the Projector-specific information below.*

Christie D4K-40 RGB - Landscape

WARNING: This projector is HEAVY. You will need at least four people or a mechanical lifting device to install it in the enclosure. Do not attempt to lift the projector if in any doubt about your lifting capacity.

Tempest provides a special internal fan box to hang on the right side of the projector, to ensure delivery of adequate inlet airflow, required for landscape versions only.

Install the Fan box using the M12 screws provided, into the M12 threaded holes in the top of the projector, as shown here.

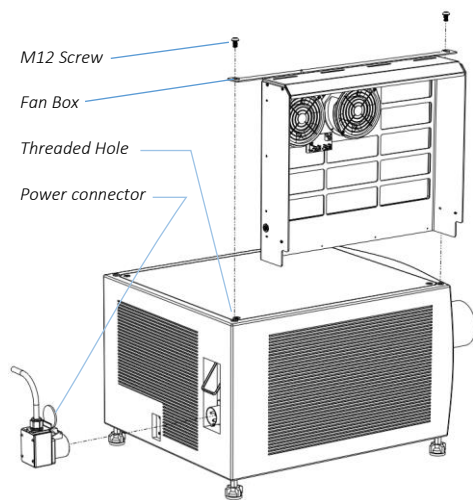

All D4K40 enclosures are supplied with a power pigtail with a 90-degree IEC309 female connector to mate to the projector power inlet.

Note: *Locate the D4K40 projector feet in the round openings provided in the projector tray. This is important for optimal airflow.*

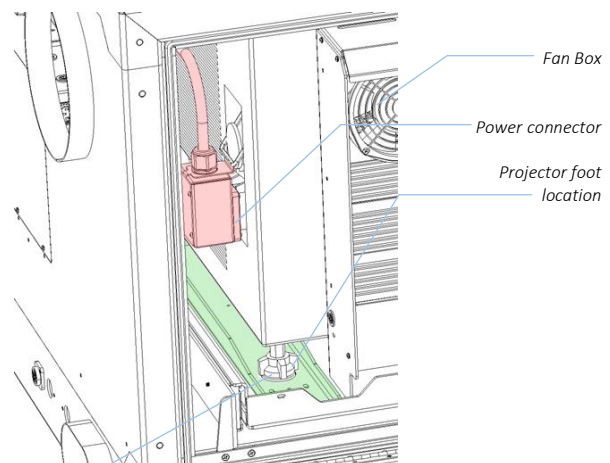
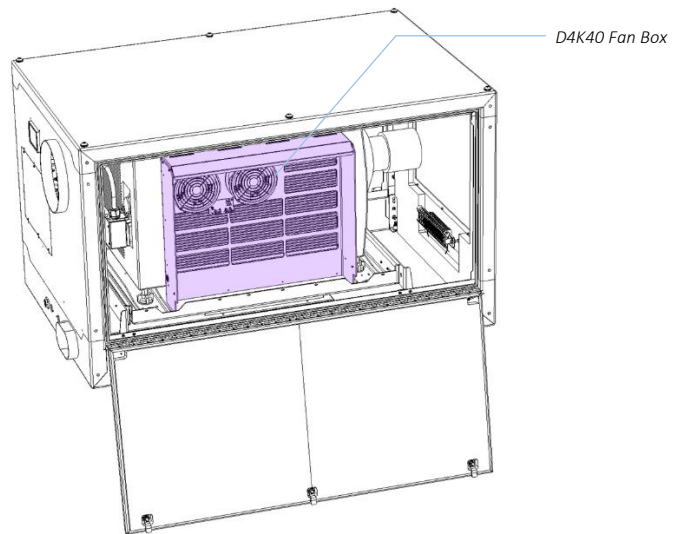

Christie D4K-40 RGB – Portrait

WARNING: This projector is **HEAVY**. You will need at least four people or a mechanical lifting device to install it in the enclosure. Do not attempt to lift the projector if in any doubt about your lifting capacity.

Tempest provides a custom projector mount, with the ability to install the projector either horizontal or at a tilt angle up to 6° up or down.

IMPORTANT: The projector **MUST** be installed air inlet down, connector panel up, as shown. Installing any other way will lead to overheating.

The illustrations here show the projector tilted DOWN. If you need to tilt UP, install the mounting bars with the Square adjustment holes to the FRONT.

1. Set the projector on the ground, with the connector panel DOWN and the air inlet UP.
2. Bolt the mounting rails to the M12 threaded holes in the projector chassis, as shown:
3. NOTE: the square holes in the Tilt Bar are set 1.5° apart, so you can set the projector either horizontal, or tilted up to 6°. It is much easier to do this now than when the projector is installed!

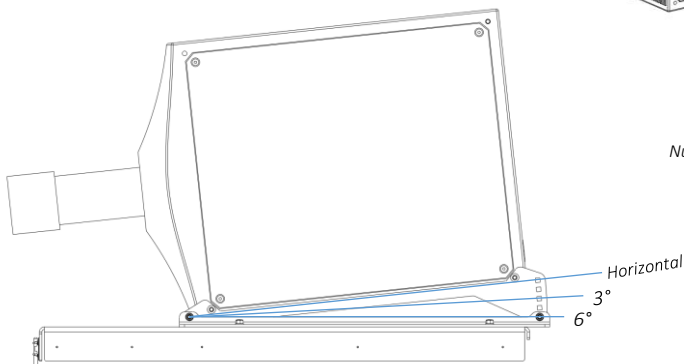

4. Now, flip the projector and set onto the enclosure tray.
5. Adjust position so the front of the lens is about 25mm (1in) from the port glass.
6. Bolt the Mounting Bars to the Projector Tray with the carriage bolts, nuts and washers supplied

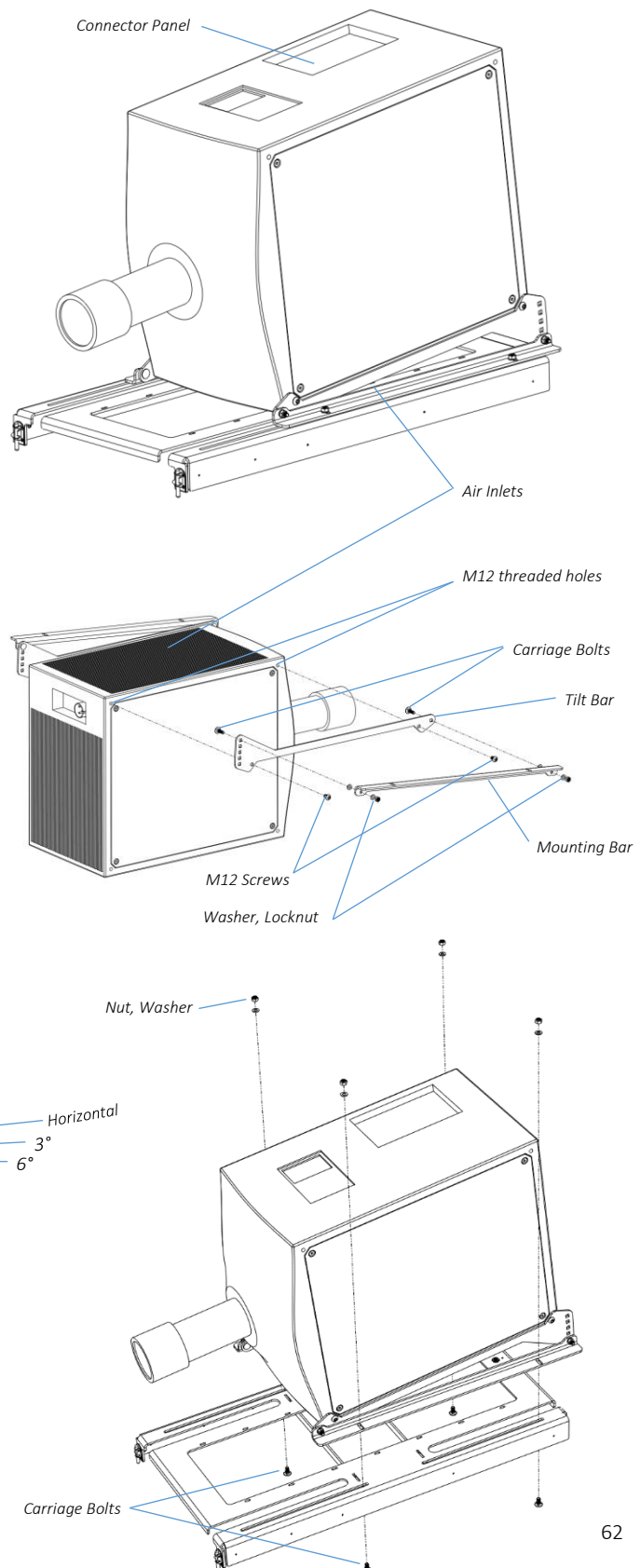

Christie J-Series/Roadster Family

The lamp exhaust from these projectors requires a special chimney (provided) to direct the hot air into the enclosure exhaust fan.

Adjust so that the rubber bulb seal around the chimney is seated snugly to the projector lamp door.

Failure to follow this step will very likely lead to hot air recirculating and serious overheating.

Illustration shows portrait mount. The lamp exhaust chimney is the same for portrait and landscape enclosures.

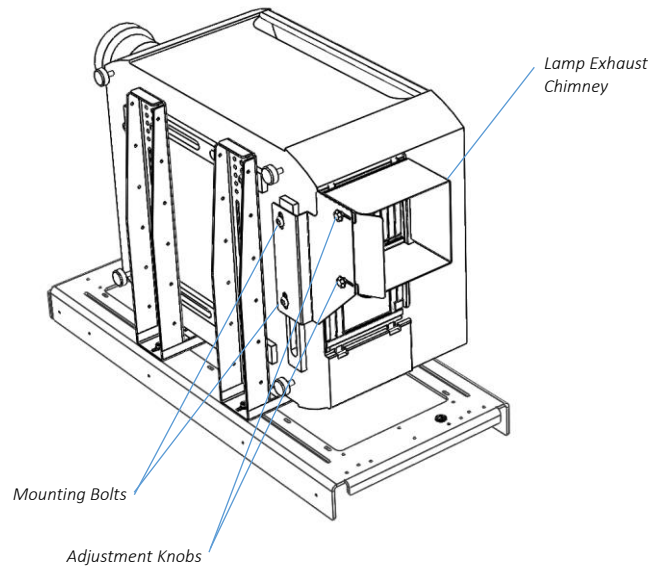

Barco HDX

The lamp exhaust from this projector requires a special chimney (provided) to direct the hot air into the enclosure exhaust fan.

Adjust so that the sliding sides of the chimney are seated snugly around the projector lamp exhaust (a vertical slot in the back of the projector).

Failure to follow this step will very likely lead to hot air recirculating and serious overheating.

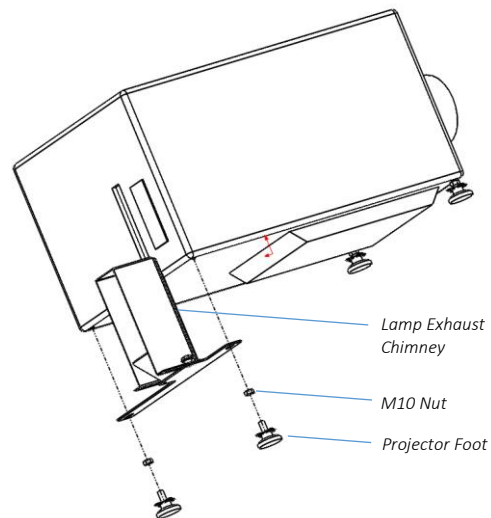

DPI Insight 4K

The lamp exhaust from this projector requires a special chimney (provided) to separate the rear inlet from hot rear exhaust air.

Adjust so that the sliding sides of the chimney are seated snugly around the projector lamp exhaust (a vertical slot in the back of the projector).

Failure to follow this step will very likely lead to hot air recirculating and serious overheating.

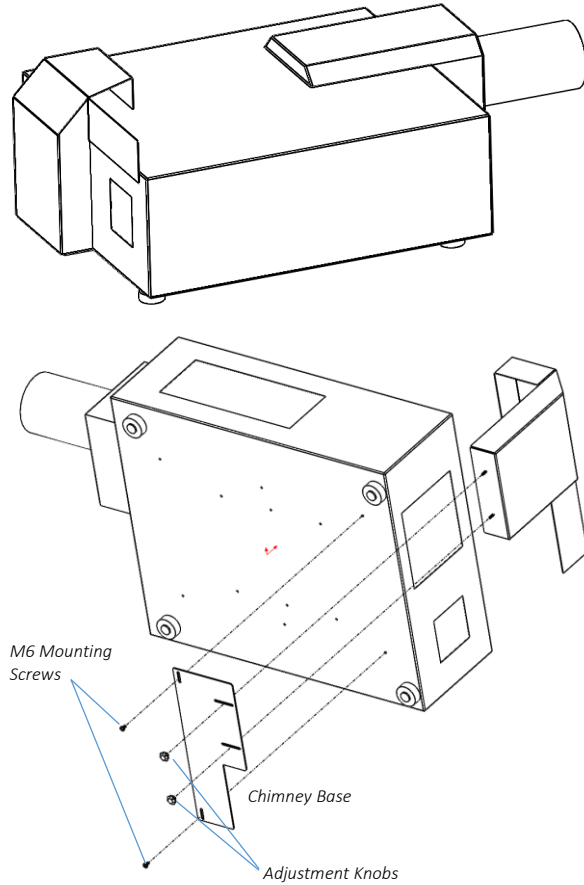

Routine Maintenance

Check the following every six months:

Clean Port Glass

Clean port glass using a window cleaning fluid or detergent. Use a soft, lint free cloth.

Check Filter

In most cases the filter will be good for 1-2 years. If the filter becomes clogged the temperature inside the enclosure will start to rise. This is an indication that the filter must be changed.

Part Numbers:

51.HF.15 Cyclone 55.200-350 Replacement Filter

51.HF.22 Cyclone 55.400 and up Replacement Filter

To replace filter from below

1. Remove the filter clamp screws.
2. The filter will drop out.
3. Replace filter and filter clamp.

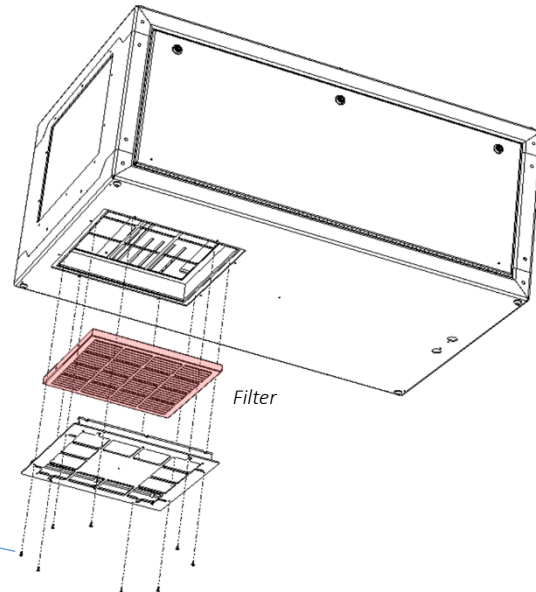

To replace the filter from inside the enclosure

1. Slide the projector tray out
2. Remove the eight M4 nuts holding the filter assembly
3. Remove the filter assembly
4. Remove the filter clamp screws
5. Replace the filter and filter clamp
6. Replace the filter assembly

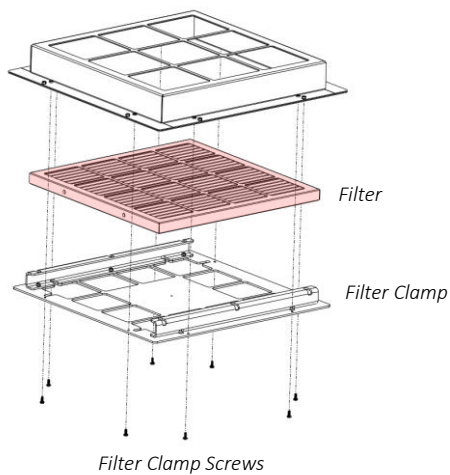
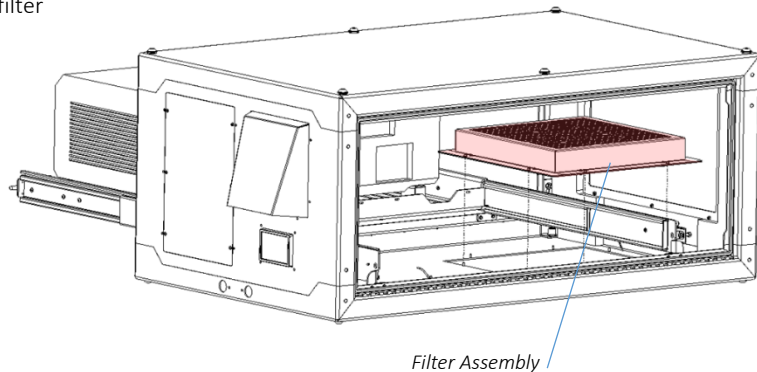

Check Temperature/Humidity Sensor

If the sensor above the port glass is defective, the controller may not operate correctly. A defective sensor will result in one of three messages appearing on the DEC user interface.

If you see any of these messages, contact Tempest for a replacement sensor.

RH: 5%

RH: 100%

RH: ####

For After Sales Support

Contact your Tempest dealer or email info@tempest.biz

Troubleshooting

| | |
|--|---|
| Projector does not have power: | <ol style="list-style-type: none"> 1. Check Projector power switch 2. Check projector is plugged into DEC4 projector outlet 3. Check that enclosure feed circuit is on 4. Check DEC4 User Interface leds are on. If feed circuit is on and UI leds are off, check feed wiring to DEC terminals and meter DEC4 projector outlet for power 5. If UI lamp led is on and DEC4 projector outlet is live, there is a projector fault. |
| Enclosure overheats: | <ol style="list-style-type: none"> 1. Is the projector connected to the DEC4 projector receptacle? If the projector is powered independently the controller has no way to know when to turn on the exhaust fans! 2. Is the filter clogged or obstructed? 3. Check that the Fan led on the UI is on when the projector is running. If not, then the projector is probably not connected to the DEC (see 1). 4. If the fan led is on, check that the fan is running. If not, check fan wiring. If wiring is ok, fan may be faulty. 5. Check the UI display for RH (relative humidity) message. If display reads RH 5%, RH 100%, or RH####, there is a sensor fault. Contact Tempest for a replacement sensor. |
| Dirt/Debris inside enclosure | <ol style="list-style-type: none"> 1. Filter is either missing or damaged? 2. Filter is not properly seated 3. Side panels or back door is not firmly latched |
| Water in enclosure | <ol style="list-style-type: none"> 1. Check the drain holes in the bottom of the enclosure. If they become blocked, and water that gets in cannot escape. 2. Check seals around side panels and back door |
| Fan LED is on but fans do not operate | <p>The exhaust fan is protected by a 20mm 4A slow-blow fuse on the DEC4 motherboard, and a secondary fuse on the fan board. In very exceptional cases it is possible that either fuse could fail. Check visually.</p> <p>The fuse is protected with a clear resin sealant and soldered to the circuit board. With care, you can de-solder the fuse and replace it, but we recommend replacing the DEC4 motherboard to maintain the integrity of the board's conformal coating.</p> |
| Heater LED is on but heater does not operate | <p>The heater is protected by a 20mm 10A slow-blow fuse on the DEC4 motherboard. In very exceptional cases it is possible that it could fail. Check visually.</p> <p>The fuse is protected with a clear resin sealant and soldered to the circuit board. With care, you can de-solder the fuse and replace it, but we recommend replacing the DEC4 motherboard to maintain the integrity of the board's conformal coating.</p> |
| None of the above? | <p>Contact info@tempest.biz</p> |

Warranty

INSPECTION/WARRANTY/RETURNS.

A. Customer, at its sole expense, shall inspect all Goods promptly upon receipt and accept all Goods that conform to the specifications or catalog. All claims for any alleged defect in or failure of the Goods or Seller's performance to conform to the Contract, capable of discovery upon reasonable inspection, must be set forth in a written rejection notice detailing the alleged non-conformity, and be received by Seller within thirty (30) calendar days of Customer's receipt of the Goods. Failure by Customer to notify Seller of the alleged non-conformity within thirty (30) days will be conclusive proof that the Goods have been received by Customer without defects or damage, and in the quantities specified on the bill of lading and shall constitute an irrevocable acceptance of the Goods and a waiver of any such claim in connection with the Goods.

B. Seller warrants to Customer only that the Goods will be free from defects in material and workmanship at the time of delivery and, subject to the exceptions and conditions set forth below, for the following period (the "Warranty Period"): twelve (12) months from the date of shipment by Seller. Seller may provide additional years of warranty coverage beyond 12 months, at the rate of 2.5% of the net sale price per year, up to a total of four additional years' coverage beyond the standard 12 month warranty period. Seller will remedy a defect as set forth in paragraph 7 D, below, (the "Warranty"). The Warranty is subject to each of the following exceptions and conditions:

1. Customer must promptly (and in all events within the Warranty Period) notify Seller of any alleged defect in a written notice (the "Notice") which shall set forth the quantity, catalog number, finish, original purchase order number, Seller's invoice number on which Goods were originally billed and a statement of the alleged defect, along with digital photographs showing such defects where feasible.
2. The Warranty shall not apply: (i) to any claimed defect that was capable of discovery upon reasonable inspection and deemed to be waived under paragraph A, above; (ii) to any Goods that have been subject to misuse, abnormal service or handling, or altered or modified in design or construction; (iii) to any Goods repaired or serviced by any person other than Seller's authorized service personnel or to Goods installed other than according to installation instructions, or (iv) with respect to normal wear and tear.
3. Seller makes no Warranty with respect to parts or components that are not the product of Seller, and specifically makes no warranty whatsoever for equipment housed inside enclosure products manufactured by Seller.
4. The Warranty is Seller's exclusive warranty with respect to the Goods. Seller makes no warranties, guarantees or representations, express or implied, to Customer except as set forth in this section. ALL OTHER WARRANTIES, EXPRESS OR IMPLIED, INCLUDING, WITHOUT LIMITATION ANY IMPLIED WARRANTY OF MERCHANTABILITY OR OF FITNESS FOR USE OR FOR A PARTICULAR PURPOSE, ARE HEREBY EXCLUDED AND DISCLAIMED.

C. Seller will accept the return of Goods properly rejected under paragraph A, above, or as to which Notice of an alleged breach of Warranty has been timely given and such Goods may be returned to Seller, freight prepaid, but only upon Customer's receipt of Seller's written return material authorization ("RMA") and shipping instructions. The RMA shall be void if the Goods are not received within 45 days after issuance of the RMA. No deduction or credit in respect of any rejected or returned Goods shall be taken until Customer has received Seller's further written deduction or credit/authorization following Seller's inspection to confirm nonconformity or defect. Seller will charge to Customer any and all costs incurred by Seller in connection with the handling, shipping, inspection and disposition of any returned Goods that are determined by Seller not to have been nonconforming upon Delivery or as to which the warranty hereunder is not applicable.

D. UPON ANY PROPER RETURN PURSUANT TO PARAGRAPH C, ABOVE, WHETHER IN CONNECTION WITH A REJECTION OF GOODS OR AN ALLEGED BREACH OF WARRANTY AND BASED UPON THE CONDITIONS SET FORTH IN THIS PARAGRAPH 7, SELLER AGREES THAT IT WILL, AS THE SOLE AND EXCLUSIVE REMEDY UNDER THE CONTRACT OR OTHERWISE, FOR ANY NONCONFORMITY OR BREACH OF WARRANTY, AND AT SELLER'S SOLE ELECTION: (i) REPAIR SUCH GOODS; OR (ii) REPLACE SUCH GOODS.

Appendix – TEMP Protocol

AVAILABLE TO SPECIAL ORDER

Tempest can optionally provide a firmware load that facilitates TEMP over RS485, suitable for interfacing to an Ethernet adapter. TEMP is a lightweight proprietary ASCII based protocol, intended for rapid integration into management systems. With TEMP and a suitable RS485 to Ethernet adaptor connected to the DEC DMX connectors, your DEC may be configured and monitored over an IP network.

Please contact factory for ordering information.

Physical Layer

1. EITHER: Use a 51.EN Ethernet daughter board plugged directly to the DEC4 motherboard, connected to your TCP/IP network.
2. OR: Use a 51.485 RS485 daughter board on each of a number of DEC4 motherboards, connected in a daisy-chain, and use a 51.EN Ethernet board on the first DEC4 to connect to your TCP/IP network.

Developer's Guide

Download the Developer Guide from www.tempest.biz/tech-support.