



TEMPEST

Tacit^{G4}

Hush
Projector
Enclosures
20-45K



G4 Fourth
Generation
Projector
Enclosures

Tacit Hush Projector Enclosures

Tempest is the world's leading manufacturer of large format indoor projector enclosures for noise attenuation in presentation suites, digital cinema, live theatre and concert venues – any noise-sensitive indoor space. Tacit models are projector-specific for larger video projectors, and have been tested and approved for each of the projectors covered, up to 45,000 ANSI lumens.

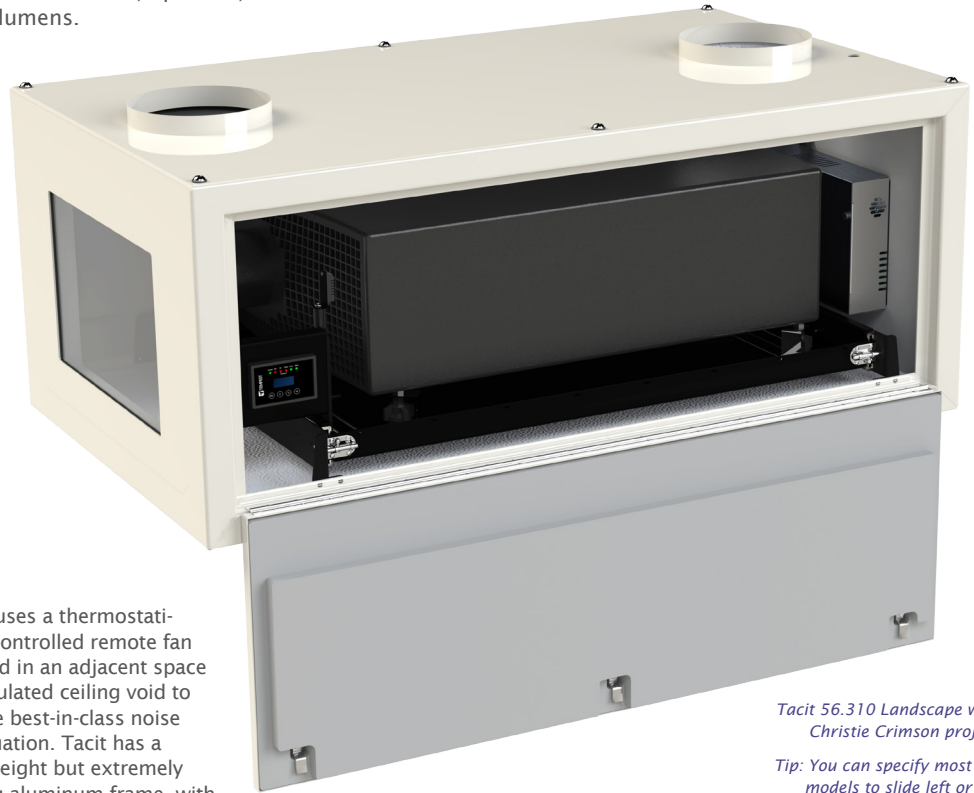

Tacit uses a thermostatically controlled remote fan located in an adjacent space or insulated ceiling void to assure best-in-class noise attenuation. Tacit has a lightweight but extremely strong aluminum frame, with threaded holes at six points for easy installation.

Tacit offers excellent projector access, with full-length lockable side access doors, and a projector slide that may be ordered for right or left access on all landscape and portrait models.

Standard colors: White (RAL 9003 semi-gloss, black). Other colors to order.

Tacit is equipped with Tempest's patented DEC4 Control, featuring a comprehensive display and remote monitoring options.

Portrait and Ultra-Short-Throw versions are available to special order.

Tacit 56.310 Landscape with a Christie Crimson projector

Tip: You can specify most Tacit models to slide left or right

Why so Quiet?

There are several parts to the puzzle:

- First, Tacit enclosures are airtight boxes with excellent seals, which do much of the work.
- Second, we line Tacit enclosures with two layers of high performance melamine sound insulation foam — rated incidentally to the highest fire safety standards.
- Third, we put the exhaust fan someplace else. As a rule of thumb, you need to blow through an enclosure about double the amount of air being handled by the projector itself.

That means forced cooling, and that means noise. The Tacit exhaust fan is located at the end of a duct (by others), which may be in an insulated ceiling space, an adjoining room or an outside wall.

The exhaust fan may also feed into the building air return, though we don't recommend feeding air to the enclosure inlets from the building air supply. It should be brought in at moderate temperature from a room or ceiling void.

This combination achieves excellent attenuation in the audience space, which is our sole aim.

Now Tempest Tacit enclosures monitor air temperature where it matters — right next to the projector air inlet. You can set a target air inlet temperature limit, and Tacit's variable speed remote fan will blow just hard enough to keep it there.

You told us that our user interface was great, but that it could be distracting or hard to reach on the outside. So now it's right where you need it, next to the projector.



Tacit Hush Projector Enclosures

Landscape

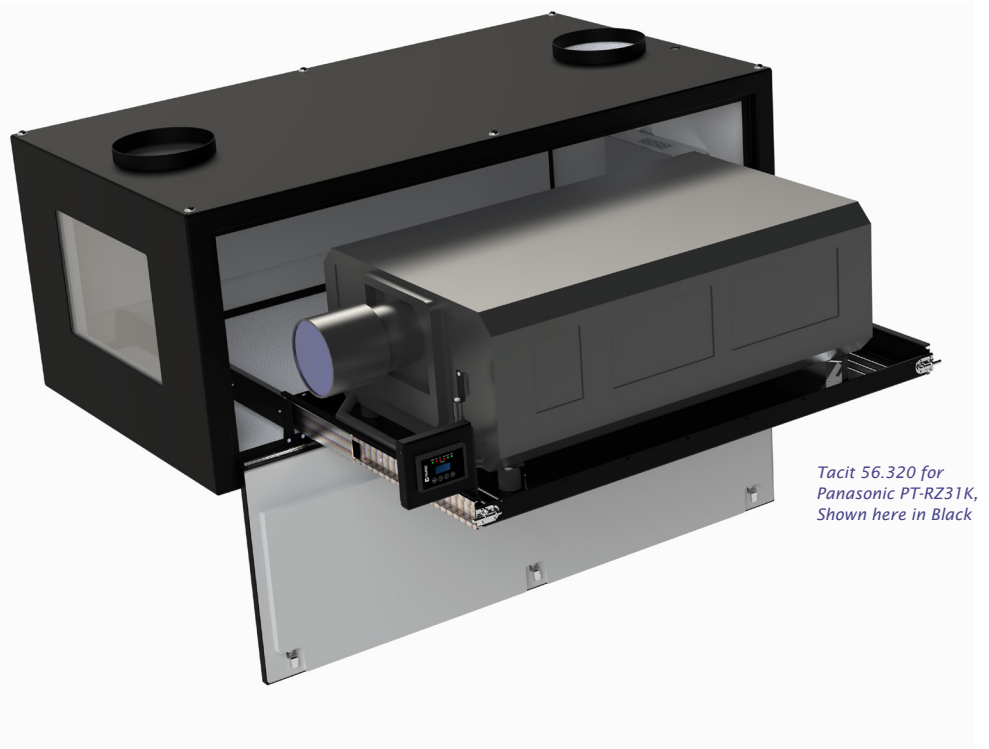
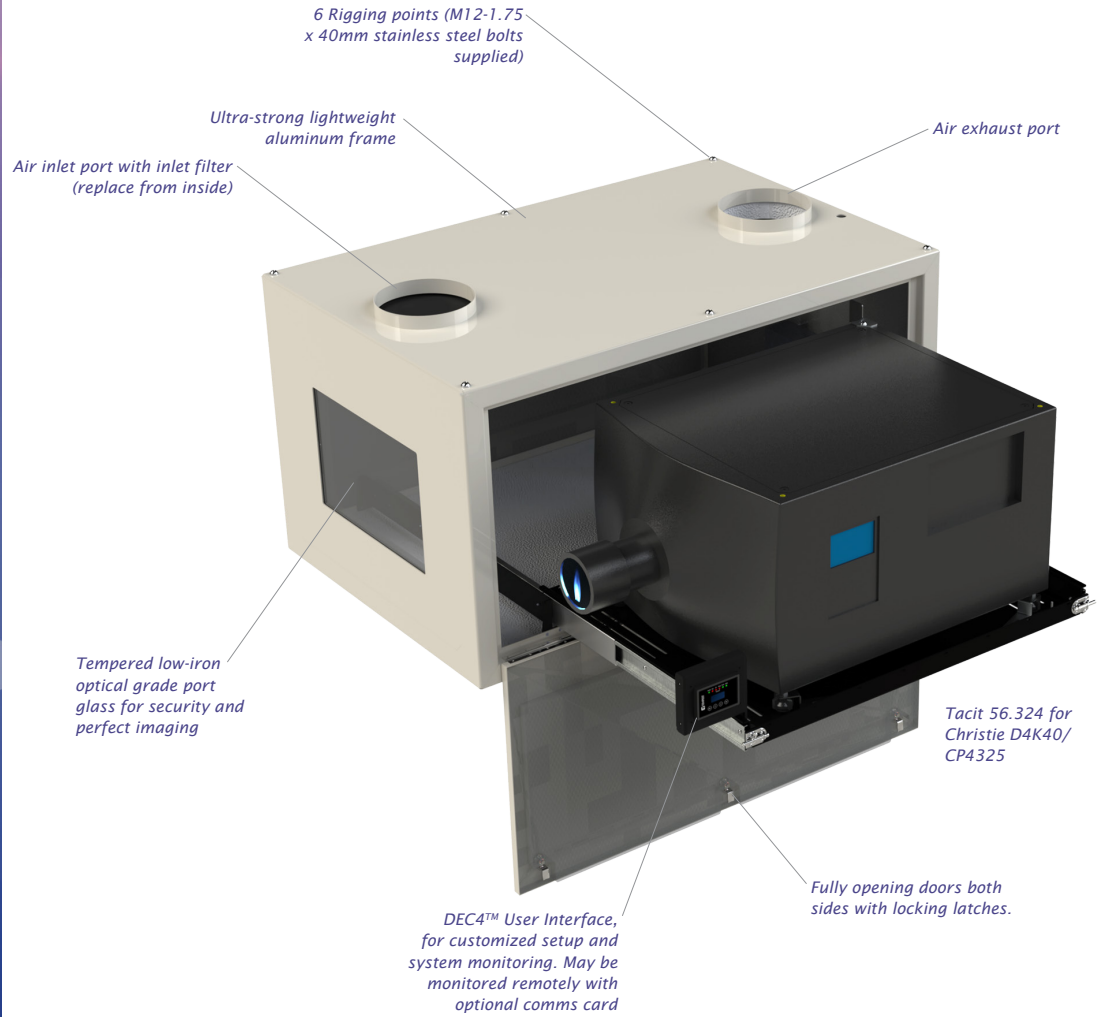

Tacit Hush Projector Enclosures

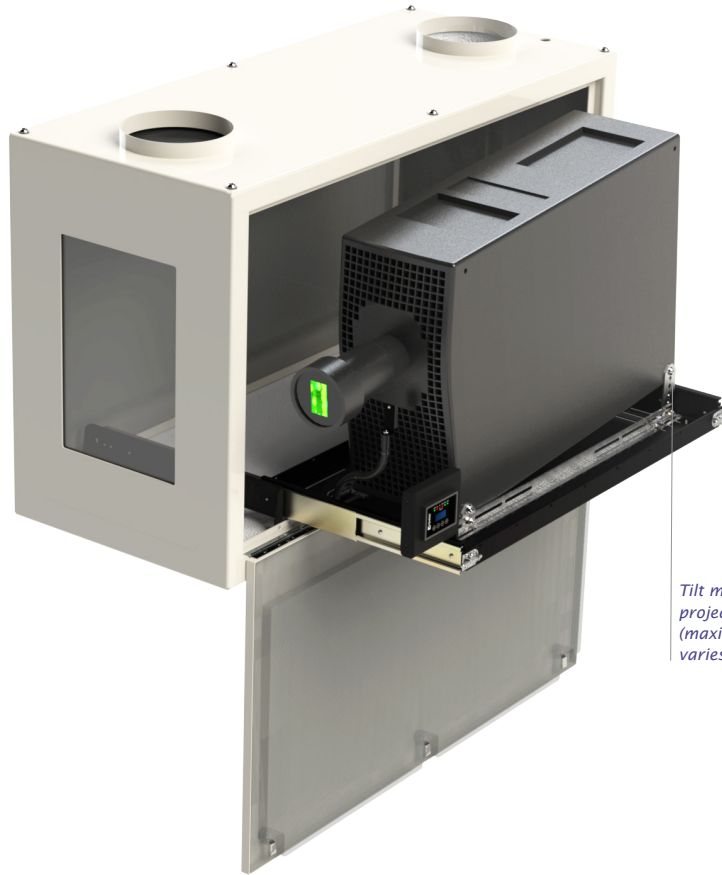

Portrait

Like all Tacit models, each Tacit portrait enclosure is customized for the intended projector, so we need to know the projector you're using when you order.

Not all projectors may be used in portrait mode — check with your projector manufacturer before ordering.

Some projectors may be used in portrait mode but only in one orientation — either base left or base right (picture here shows a Christie Crimson installed base left).

Tilt mechanism allows projector tilt adjustment (maximum tilt angle varies by projector).

Ultra Short Throw

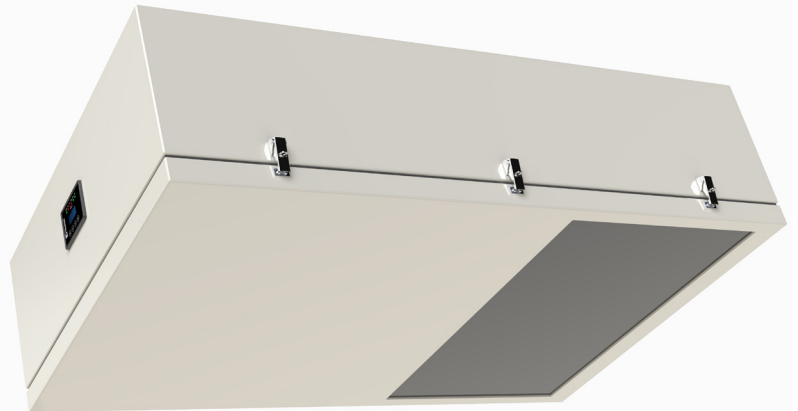

Tacit UST enclosures allow you to paint the whole wall from just above or below. UST enclosures are wider than standard landscape enclosures, to allow for the extreme width of the projection beam without clipping.

Tacit UST enclosures may be configured to mount above the image (projecting down) or below it (projecting up). Due to the wide variety of UST lens solutions on the market, Tacit UST enclosures are specially

built for your project: Contact Tempest and talk to us about your next UST adventure!

Tacit Hush Projector Enclosures

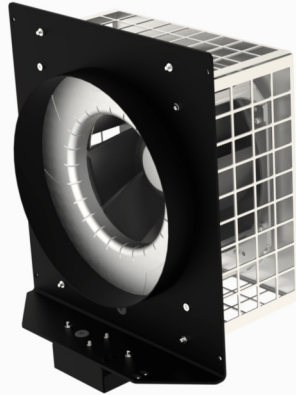

Tacit Remote Blower Kit

51.RFA.270 (included)

This powerful blower must be located in an adjoining space to the Tacit enclosure, out of audience earshot. Connection to the enclosure is via one 2-conductor power cable (48Vdc, 120W), and one twisted pair for speed control and status feedback - a CAT5 cable is fine. The cable may be pulled back to the enclosure through the exhaust duct if desired.

Mount the blower kit either in a convenient space in free air, or in the side of a building return HVAC duct.

Ductwork (by others)

For best results, install 250mm (10") air ducts for air inlet and exhaust.

The exhaust duct should be as short as possible (maximum 10m/30ft), and with a minimum of sharp bends, to optimize airflow.

The inlet duct should ideally connect to an adjoining air-conditioned space, for best cooling and acoustic performance. DO NOT pull air from the building HVAC supply if it may be used for heating as well as air conditioning.

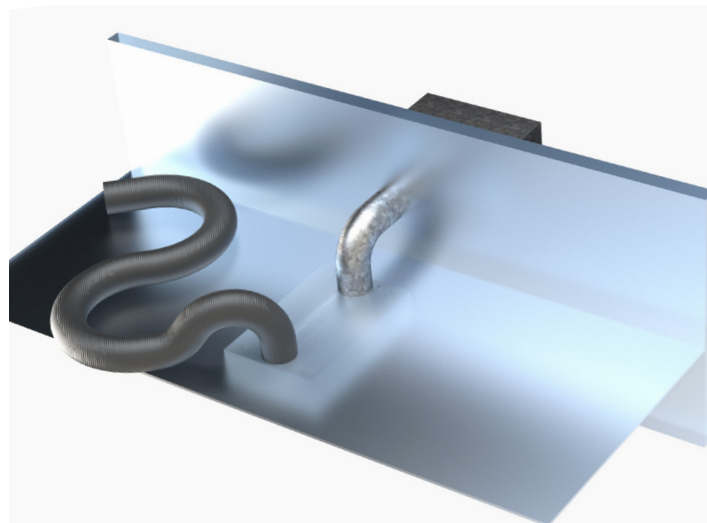
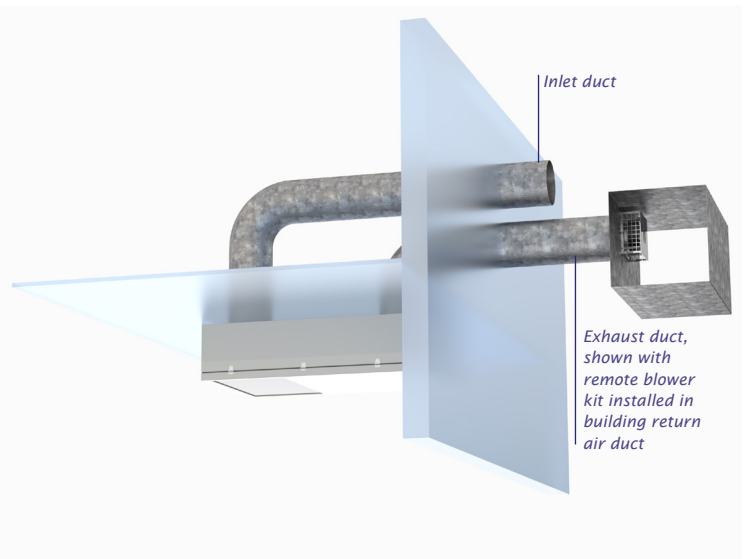

Rigging Points

Each Tacit enclosure is supplied with six 12mm threaded holes in the top surface, for suspension of the enclosure using either M12-1.75 threaded rod or bolts (supplied).

Tacit enclosures may be supplied with Unistrut rails fitted to speed up installation.

Important: most Tacit enclosures are hung above an audience; for the sake of appearance, there are no rigging points on the underside. For installations where such rigging points are required, please specify with your order on the configuration sheet at the back of this brochure.

If it is impractical to bring inlet air from a remote location, use a length of padded flexible hose (250mm/10in ID) in an 'S' configuration to draw in air and muffle any noise escaping through the air inlet path.

In cases where additional ductwork is not feasible such as in historic buildings, consider Tempest's *Zen* standalone enclosures.

Tacit Hush Projector Enclosures

Fan Speed Control

Your Tacit enclosure uses a powerful variable-speed blower in a remote location to keep the projector at optimum operating temperature.

The remote blower will run at the minimum speed required to maintain the target projector inlet temperature, keeping fan noise to a minimum and enabling virtually infinite fan life.

Tacit's temperature sensor is now located exactly where you need it - right by the projector's inlet vent, and user settings allow you to set a target inlet temperature to suit the needs of your particular projector.

Individual Fan Monitoring

G4 Tacit enclosures can also tell you how each fan in a whole installation is performing. DEC4 compares calculated and actual fan speed, and is able to alert you if one of the fans in a system needs attention.

Combined with Tempest's upcoming remote monitoring service this means you could be receiving an alert on your smartphone one day telling you it's time to check the fan on enclosure two!

51.485 RS485 Comms Board

Daisy-chain a group of Tacit enclosures together with this RS485 board — one per enclosure.

51.EN Ethernet Comms Board

Connect each Tacit enclosure directly to your network and monitor using simple-to-use TEMP protocol queries.

51.ENB Ethernet Comms Bridge

Use this RS485/Ethernet adapter to connect one Tacit or a group of Tacit enclosures connected using RS485 to a PC or Tempest System Manager

51.TSM System Manager

The Tempest System Manager monitors any Tempest G4 system, with any number of enclosures. System manager may be connected to a PC for local monitoring, and/or to the internet, for remote monitoring.

G4 Fan Control

System Monitoring

51.RMS Remote Monitoring Service

We do the work for you! We monitor your installation 24/7 and send you email alerts if we spot anything out of the ordinary. Coming soon.

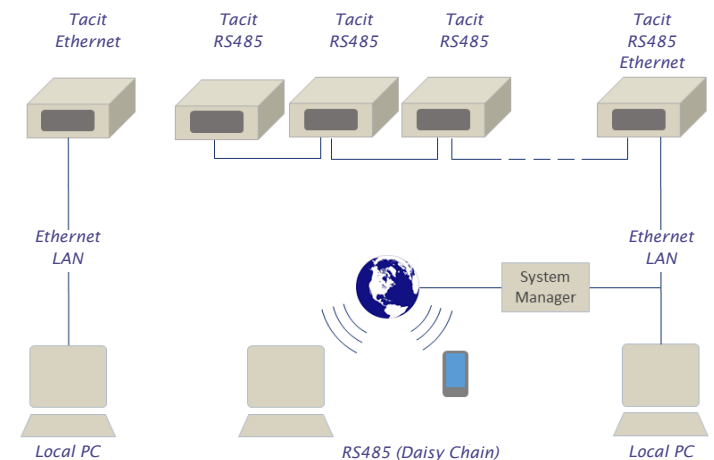

For more on DEC4 and remote monitoring, download the Tacit User Manual from www.tempest.biz

Tacit G4 Ordering Guide

Model	Orientation	Dimensions (lwh)	Weight	Projector Type ¹	Shipping Dimensions/Weight
56.150.L	Landscape	42x30x20 107x76x51cm	120lb/55kg	Barco F80, F90, Christie H/HS Series, DPI M-Vision 930, Epson L-1700, Panasonic PT-RS11, RZ12, RQ13	52x32x24in/132x86x61cm 160lb/73kg
56.150.P	Portrait	42x20x30 107x51x76cm	130lb/59kg		52x32x24in/132x86x61cm 170lb/77kg
56.210.L	Landscape	50x35x24in 130x81x56cm	146lb/66kg	Panasonic PT-DZ21K, PT-RZ12K, PT-RQ13, PT-RZ21K, PT-RQ35K, Barco F90-W13, DPI Highlite 4K, Titan Quad	70x38x32in/178x97x81cm 253lb/115kg
56.210.P	Portrait	50x22x36in 130x56x86cm	175lb/80kg		70x33x50in/178x84x127cm 305lb/139kg
56.250.L	Landscape	50x38x24in 130x97x61cm	188lb/86kg	Epson Pro L25000U	70x38x32in/178x97x81cm 327lb/149kg
56.250.P	Portrait	50x26x41in 130x66x104cm	212lb/96kg		70x33x50in/178x84x127cm 368lb/167kg
56.310.L	Landscape	59x35x25in 150x86x64cm	203lb/92kg	Christie Boxer, Crimson, Barco UDX	70x38x32in/178x97x81cm 353lb/161kg
56.310.P	Portrait	59x24x36in 150x61x91cm	224lb/102kg		70x33x50in/178x84x127cm 389lb/177kg
56.320.L	Landscape	67x38x27in 157x97x76cm	247lb/112kg	Panasonic PT-RZ31K, RQ32K, Barco HDF, DPI Insight Dual	70x44x32in/178x112x81cm 430lb/196kg
56.320.P	Portrait	67x26x39in 157x66x96cm	260lb/118kg		70x33x50in/178x84x127cm 452lb/206kg
56.324.L	Landscape	58x38x32in 147x97x81cm	247lb/112kg	Christie CP4325, D4K40-RGB	70x38x32in/178x97x81cm 430lb/196kg
56.324.P	Portrait	58x30x43in 147x76x109cm	260lb/118kg		70x33x50in/178x84x127cm 452lb/206kg
56.400.L	Landscape	62x38x38in 157x97x97cm	260lb/118kg	Barco B-Series	76x44x46in/193x112x117cm 468lb/213kg
56.450.L	Landscape	71x38x38in 180x97x97cm	280lb/127kg	Christie D4K35, CP2220/30	76x44x46in/193x112x117cm 529lb/239kg
56.525.L	Landscape	67x38x29 157x97x74cm	260lb/118kg	Panasonic PT-DZ50K, PT-RQ50K	76x44x46in/193x112x117cm 468lb/213kg
56.525.P	Portrait	67x29x40 157x74x102cm	280lb/127kg		76x44x46in/193x112x117cm 488lb/222kg

¹ For projectors not shown here, please contact factory — we will be happy to accommodate any projector type

All Tacit Enclosures are built to order. Please consult factory for lead times.

All Tacit UST Enclosures are Custom or Semi-Custom. Please consult factory for details.

All sales are subject to Tempest Lighting, Inc. Standard Terms and Conditions, available for download at www.tempest.biz.

All Schedule B Export Code: 9405.99.0000

Custom Colors

The enclosures in this brochure are shown in our standard warm white semi-gloss or black. Any RAL color available to special order.

Options

56.UR.xxx	Unistrut Rail Kit (Use the 3-digit enclosure model #, eg 56.UR.200 for Tacit 56.200)
51.IFL11	Replacement Inlet Filter Tacit 56.1xx-3xx Models
51.IFL13	Replacement Inlet Filter Tacit 56.400 and up
51.EN	Ethernet Monitoring
51.TSM	Tempest G4 System Manager (coming soon)
0000.CL	Custom Color — specify any RAL #, plus % gloss desired

