



User Manual

Blizzard G4

Revision 02.6

February 2020

© Tempest Lighting, Inc.

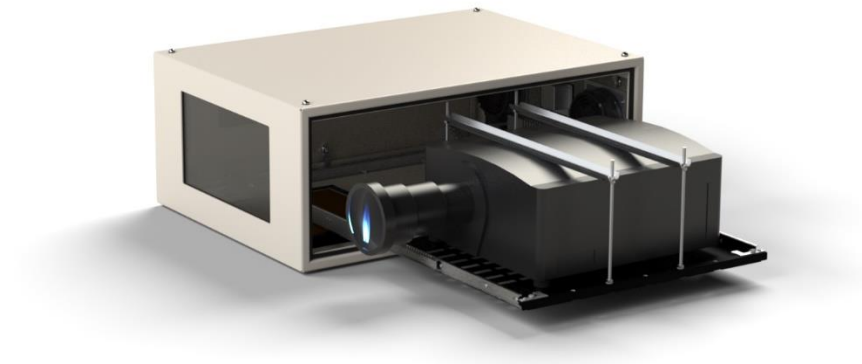

Table of Contents

Approvals – Europe	5
Approvals – China	6
Introduction	7
IMPORTANT: Safety Advisories	7
Installation.....	8
Dimensions, Rigging Points, and Maximum Projector Dimensions/Power	8
Air Clearance.....	9
Snow Clearance	9
Mounting Bolts	10
Mounting Options – Stacking Kit	11
Mounting Options – Unistrut Kit	11
Mounting Options – Cyclovator.....	11
Mounting Options – Horizontal Pole Hanger Kit	12
Mounting Options – Vertical Pole Hanger Kit	12
Mounting Options – Desert Filter Baffle	13
Wiring the Enclosure	13
Power Wiring	13
SAFETY NOTICE:	13
Electrical Standards	13
Wiring Access.....	14
One or Two Power Circuits?	15
Conduit Entries	16
Single Feed Power Termination.....	17
Split Feed Power Termination	17
Remote Monitoring Connections	18
RS485 (DMX/RDM) Cable Terminations.....	19
Line Termination Switch Settings	20
DEC4 Ethernet Adapter – 51.EN	21
Default Configuration.....	21
Additional Support	21
Tempest Equipment Management Protocol	22
Projector Power Control using DMX512	23
DMX/RDM Network, using JESE RDM-TRI.....	24
Positive Pressure Fan Control Option.....	25
Mounting the Projector.....	26
Landscape & Portrait Enclosures – fixed or slide? Tabletop or ceiling?	26
Projector Fixed or Slide Mounting.....	26

Ceiling or Tabletop	26
Projector Slide Direction	27
Reversing Slide Direction	27
Mount the Projector – Fixed Mount.....	28
Tabletop Installation.....	28
Mount the Projector – Slide Mounts.....	28
Aligning and Securing the Projector	30
Projector Mount – Portrait	31
Changing Portrait Orientation	32
Projector Mount – Ultra-Short-Throw	33
Digital Enclosure Control.....	34
Schematic.....	34
DEC4 Main Functions	35
Firmware Revision	35
Factory Settings – Data Modes	35
Hardware Indicators & Fuses	36
Operating Modes.....	37
RDM Only Monitor (Factory Default)	37
RDM+DMX Control.....	37
RDM+DMX Service	37
DEC4 Control Parameters	38
Control Interface	39
User Interface LCD Display.....	40
Control Interface Operation	40
Control Menu.....	41
Set Data Options.....	41
Set Temp Units	42
Set Temp Ranges	42
Set Max Humidity	42
Set Lamp On Point.....	42
Reset Lamp Hours.....	42
Set Fan Function.....	43
Status Display.....	43
Safe Mode	44
Safe Mode – What to do:.....	44
DEC4 Firmware Updates	46
Indirect Firmware Updates	46
Requirements	46
Installation Procedure	46

Routine Maintenance	51
Clean Port Glass.....	51
Check Filter	51
Check Temperature/Humidity Sensor	52
For After Sales Support	52
Troubleshooting.....	53
Warranty	54
Appendix – TEMP Protocol.....	55
Physical Layer.....	55
Developer’s Guide	55

Approvals – Europe



CERTIFICATE AND DECLARATION OF CONFORMITY
FOR CE MARKING

Tempest Lighting, Inc.

11845 Wicks Street, Sun Valley, CA 91352, USA

t: +1 818 787 8984 f: +1 818 252 7101 e: info@tempest.biz

www.tempest.biz

Tempest Lighting, Inc. declares that their
Projector Enclosure Series 52.xxx.xx

complies with the Essential Requirements of the following EU Directives:

Low Voltage Directive 2006/95/EC Test Report G4.51.LVD

Electromagnetic Compatibility Directive 2004/108/EC Test Report G4.51.EMC

and further conforms with the following EU Harmonized Standards:

EN 60065 : 2002 Test Report 60065.G4.51.01

EN 60529:2001-2002 Test Report 60529.G4.51.02

EN 61000-6-3:2007+A1:2011 Test Report 61000.G4.51.03

EN61000-6-1:2007 Test Report 61000.G4.51.03

EN55015:2006+A2:2009 Test Report 61000.G4.51.03

Dated: 1st July 2016

Position of signatory: President

Name of Signatory: Tim Burnham

Signed below:

on behalf of Tempest Lighting, Inc.

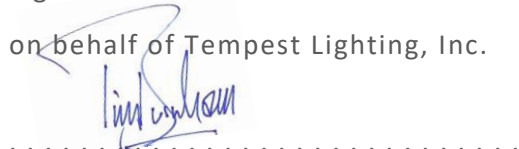

Approvals – China



强制性认证目录外产品确认书
**Confirmation Letter for Products
 Outside the Scope of China Compulsory Certificate**

Ref. No: CL-TEMPEST-160818-1

申请人: Applicant: Tempest Lighting Inc.		地址: Address: 11845 Wicks St., Los Angeles, CA 91352 United States
生产厂名称: Factory: Tempest Lighting, Inc.		地址: Address: 11845 Wicks St., Los Angeles, CA 91352, USA
产品名称: Product Name: 投影机外壳, 灯具外壳 Projector Enclosures Moving Light Enclosures Lighting Enclosures	型号: Model: 18xx.IN, 19xx.IN, 2xxx.IN, 66xx.IN, 52.xxx.IN, 53.xxx.IN, 54.xxx.IN, 55.xxx.IN, 56.xxx.IN	商标: Trademark: Tornado, Twister, Thunder, Blizzard, Whispr, Typhoon, Cyclone, Tacit
产品标准: Standard: /		HS code: 9405.99.0000
产品描述(包括使用场所) Product Description (utilization of product) : Enclosures for high-powered luminaires and video projectors for outdoor use and indoor noise attenuation. For professional use only. 产品为用于户外和室内噪声衰减大功率灯具和视频投影仪的外壳。仅供专业使用。		
确认意见 Conclusion: According to the product description, the models above are out of CCC scope. 基于产品描述, 如上型号的产品在中国强制性产品目录之外。 本确认书的有效有效期至: August 18th, 2017 Validity Period		



Introduction

Thank you for purchasing a Tempest enclosure! We have worked hard to provide you with the very best product available for its purpose, and we shall continue to do everything possible to ensure that it works well for you for many years to come.

Please read this manual before starting work!

In the event of difficulty, please contact your Tempest reseller or Tempest direct:

info@tempest.biz

+1 818 787 8984

We will do everything we can to help you get the very best results from your Tempest enclosure.

IMPORTANT: Safety Advisories

- All installation and rigging work done must where applicable be designed and built in accordance with norms and standards of the local authority having jurisdiction of the installation site. It is the responsibility of the installer to obtain such approvals as may be required to achieve full compliance.
- All electrical work must be carried out by a suitably licensed electrical contractor in full compliance with local electrical standards.
- Lifting: some enclosures and the equipment inside them may be heavy. Use properly rated lifting equipment where appropriate and never attempt to carry out work with fewer than the number of workers needed to lift safely.
- It is the responsibility of the installer to ensure that all local building, safety and electrical codes are strictly adhered to in the installation of this enclosure. Tempest Lighting, Inc., its employees and agents are in no way responsible for damage arising from failure to follow either the instructions in this manual or building, safety and electrical codes prevailing at the installation location.
- Do not attempt to install or operate the enclosure before fully reading and understanding this manual
- Never allow anyone who has not read this manual to open the enclosure or perform maintenance on the projector within.
- Never leave the enclosure unattended when open.
- Always make sure all bolts and latches are tight and safety locks are in place after performing any form of maintenance on the unit.
- Do not open any electrical boxes until power has been shut off to all supply lines to the enclosure (including the one powering the projector).
- Do not open the enclosure in wet weather.

Installation

Dimensions, Rigging Points, and Maximum Projector Dimensions/Power

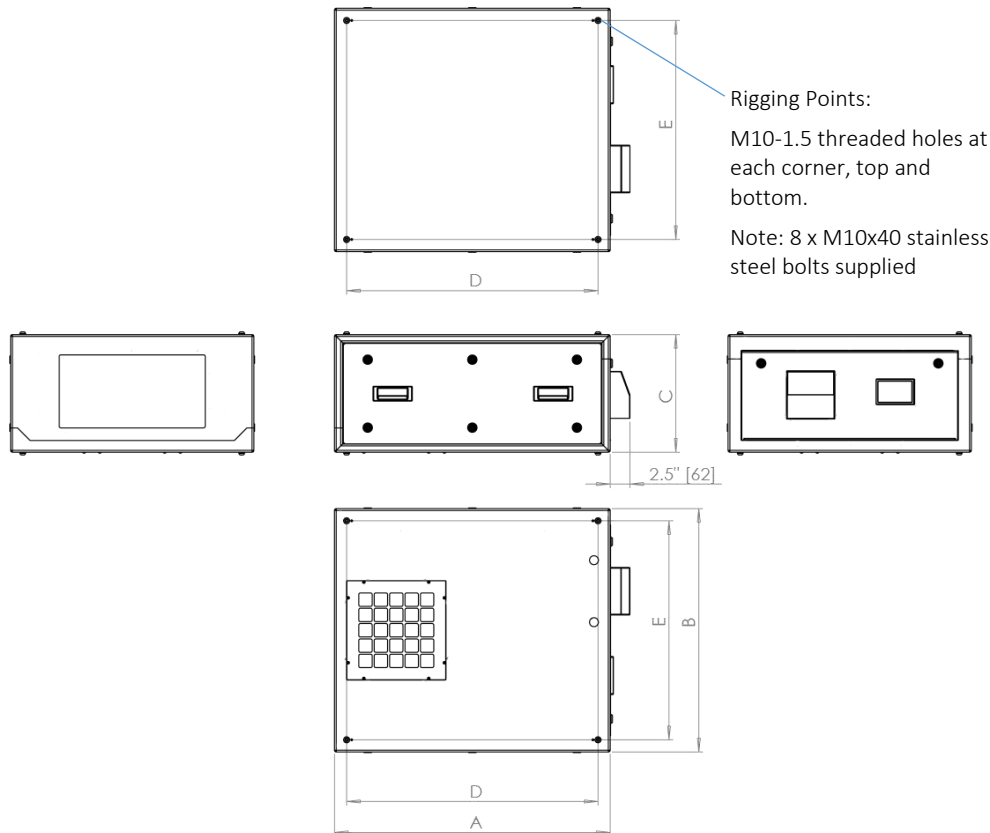

Model	Format	DIM A	DIM B	DIM C	DIM D	DIM E	Weight	Projector Max: Size (LWH) *	Projector Max Power
52.050.Lx	Landscape	737 29in	711 28in	343 13.5in	660 26in	635 25in	27kg 59lb	610x572x229 24x22.5x9in	800W
52.050.Px	Portrait	737 29in	432 17in	686 27in	660 26in	356 14in	30kg 65lb	595x572x229 23.5x22.5x9in	800W
52.050.U	Short Throw	tbd*	tbd*	tbd*	tbd*	tbd*	tbd*	tbd*	800W
52.100.Lx	Landscape	864 34in	762 30in	368 14.5in	787 31in	686 27in	32kg 70lb	695x595x275 27.5x23.5x11in	1,200W
52.100.Px	Portrait	864 34in	432 17in	686 27in	787 31in	356 14in	36kg 78lb	695x595x275 27.5x23.5x11in	1,200W
52.100.U	Short Throw	tbd*	tbd*	tbd*	tbd*	tbd*	tbd*	tbd*	1,200W
52.125.Lx	Landscape	864 34in	864 34in	368 14.5in	787 31in	787 31in	32kg 70lb	695x595x275 27.5x23.5x11in	1,200W
52.125.Px	Portrait	864 34in	432 17in	787 31in	787 31in	356 14in	36kg 78lb	695x595x275 27.5x23.5x11in	1,200W
52.125.U	Short Throw	tbd*	tbd*	tbd*	tbd*	tbd*	tbd*	tbd*	1,200W
52.150.Lx	Landscape	1067 42in	762 30in	419 16.5	991 39in	686 27in	42kg 92lb	1095x595x355 41.5x23.5x14in	1,800W
52.150.Px	Portrait	1067 42in	483 19in	762 30in	991 39in	406 16in	47kg 104lb	1095x595x355 41.5x23.5x14in	1,800W
52.150.U	Short Throw	tbd*	tbd*	tbd*	tbd*	tbd*	tbd*	tbd*	1,800W

Note: Be sure to allow for the length of the lens and for connectors, cables and cable bend radii when calculating dimensions *tbd – please consult factory

Air Clearance

Observe the minimum clearances shown around your enclosure

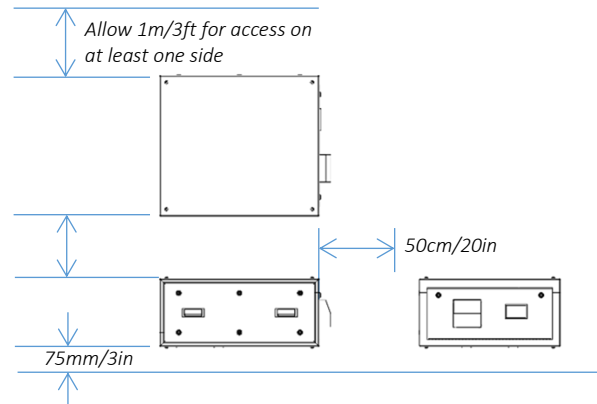

Snow Clearance

In areas where snow is likely, make sure the base of the enclosure is at least 24" [60cm] above highest potential snow drift level.

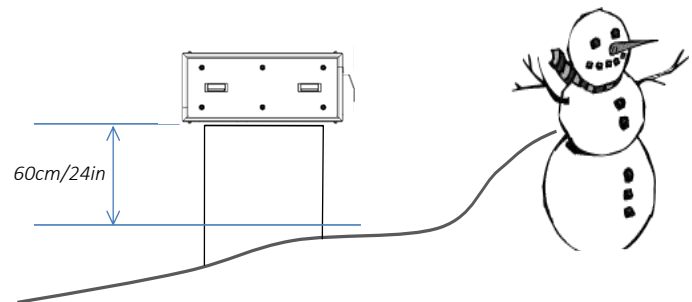

Mounting Bolts

- Each Enclosure must be mounted with FOUR points.
- All mountings must be made using the four M10 threaded holes on the top or bottom of the enclosure.
- Use a 6mm hex key to secure the M10 socket cap screws provided.
- Tempest Lighting recommends the use of stainless steel mounting hardware.
- Make sure the inlet filter has at least 75mm/3in clearance below.

⚠ IMPORTANT SAFETY NOTICES

Installer must ensure that all mounting points are secure and conform to local safety regulations. Tempest Lighting Inc. accepts no responsibility for damage or injury arising from inappropriate or unsafe installation.

Check that the tip of each mounting bolt is clearly visible below the nut welded to the internal mounting plates. If the bolt thread is not visible, remove and replace with a longer bolt.

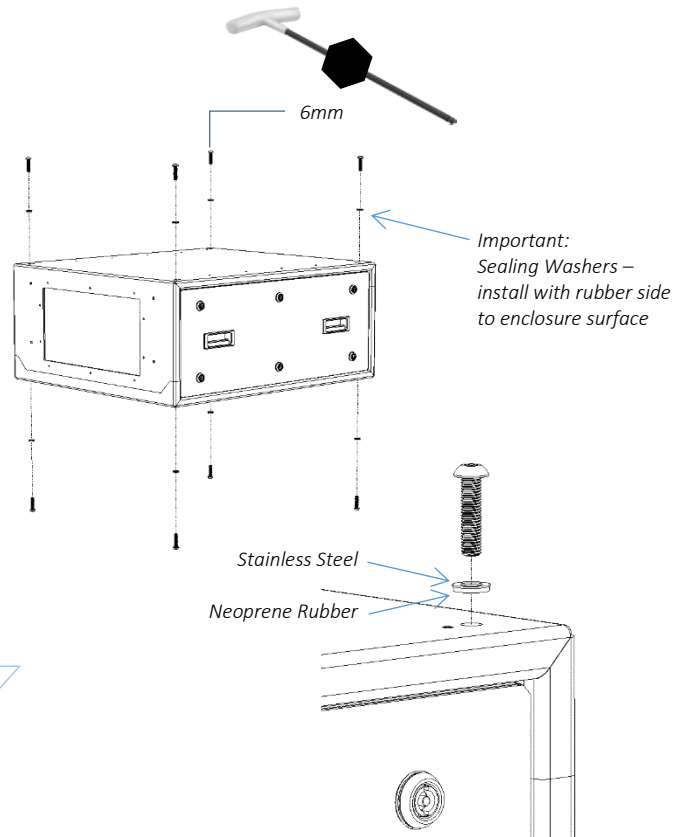
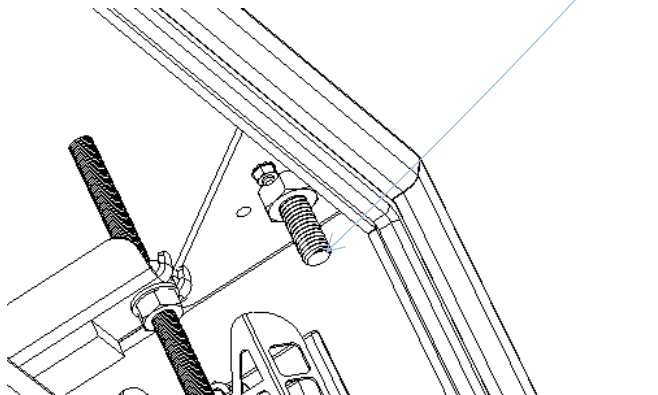

Mounting Options – Stacking Kit

Blizzard G4 may be stacked up to four units high, using the 52.SK stacking Kit. You will need the total number of Blizzards to be stacked, minus one stacking kit(s).

Note: Blizzards must be of the same model to stack in this way.

52.SK Stacking Kit (set of four, for one enclosure)

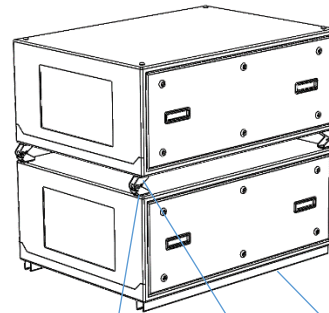

Unistrut Rails may be mounted above or below

Bolt top leg to M10 socket each corner

Bolt bottom leg to M10 socket each corner

Join top and bottom sections together with Clevis pins

Mounting Options – Unistrut Kit

If mounting positions for the corner bolts are not convenient, use the Unistrut Kit (52.UR.050/100/150) to add two Unistrut rails and Unistrut spring nuts.

Using the spring nuts, the enclosure may now be attached at any point along the Unistrut rails.

Note that the Unistrut Rail kit is required for use of Blizzard enclosures with the Cyclovator tilt kit.

Mounting Options – Cyclovator

Cyclovator allows you to mount up to two Blizzard 100 or 150 enclosures and tilt them up to 60 degrees either up (mapping up onto a building or down from a rooftop).

When enclosures are tilted more than about 30 degrees up or down, use an inlet filter cowl to protect the filter from rainfall.

55.C2 Cyclovator

52.UR.xxx Unistrut Rail Kit (required)

52.SK Blizzard Stacking Kit (only required to stack two Blizzards)

52.IC.xx Inlet Cowl

Note that the Unistrut Rail kit is required for use of Blizzard enclosures with the Cyclovator tilt kit.

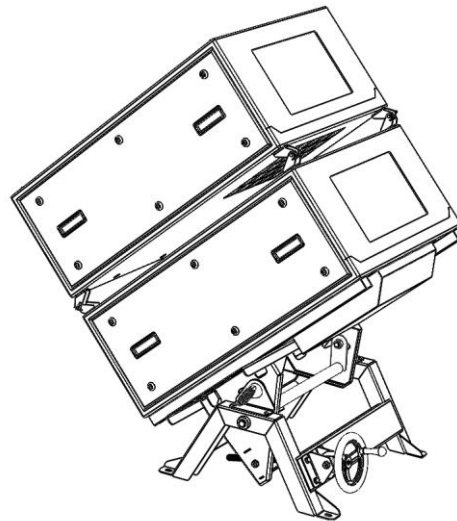

Mounting Options – Horizontal Pole Hanger Kit

Use the Truss Hanger kit to hang any Blizzard enclosure from a truss or horizontal pipe up to 50mm (2in) diameter.

Hanger kits allow XYZ 360° pan, 30° tilt, and 5° roll adjustment.

52.XH.050L	Truss XYZ Kit, Blizzard 050 Landscape
52.XH.050P	Truss XYZ Kit, Blizzard 050 Portrait
52.XH.100L	Truss XYZ Kit, Blizzard 100 Landscape
52.XH.100P	Truss XYZ Kit, Blizzard 100 Portrait
52.XH.150	Truss XYZ Kit, Blizzard 150
52.XH.150P	Truss XYZ Kit, Blizzard 150 Portrait

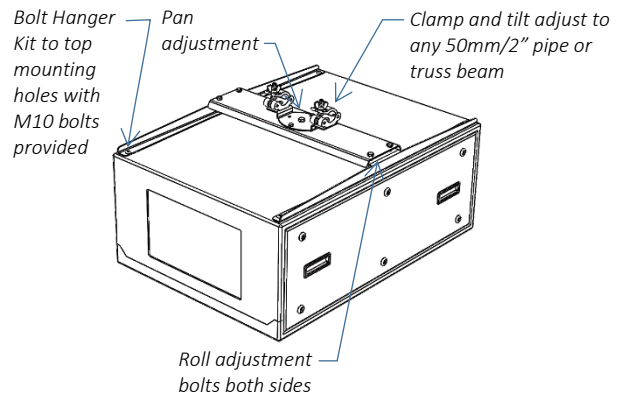

Mounting Options – Vertical Pole Hanger Kit

Use the Pole Hanger kit to hang any Blizzard 050 or 100 enclosure from a vertical pipe up to 50mm (2in) diameter.

We do NOT recommend hanging Blizzard 150 models from a single vertical pole, due to size and weight considerations. Use two vertical poles, join together with a horizontal pipe, and use the Horizontal Pole Hanger kit above.

Hanger kits allow XYZ 360° pan, 30° tilt, and 5° roll adjustment.

52.XV.050L Landscape	Vertical Pole XYZ Kit, Blizzard 050
52.XV.050P Portrait	Vertical Pole XYZ Kit, Blizzard 050
52.XV.100L Landscape	Vertical Pole XYZ Kit, Blizzard 100
52.XV.100P Portrait	Vertical Pole XYZ Kit, Blizzard 100
52.XV.150	Vertical Pole XYZ Kit, Blizzard 150
52.XV.150P Portrait	Vertical Pole XYZ Kit, Blizzard 150

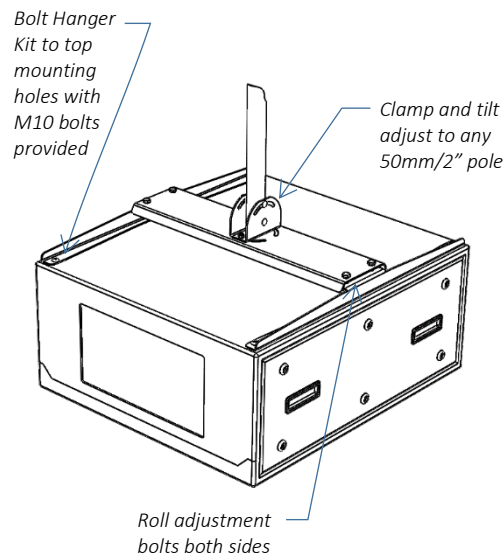

Mounting Options – Desert Filter Baffle

Use this Baffle to prevent filter damage from wind-blown sand and dust particles. If these hit the filter at speed they can quickly ‘sand-blast’ their way through it and allow fine particles to enter the enclosure.

51.DFB.11 Blizzard 52.050.L.xx/52.100.L.xx

51.DFB.15 Blizzard 52.150.L.xx

For other Blizzard models, consult factory.

Remove the Filter Grille screws, insert baffle below Grille, and replace.

Make sure there is at least 75mm [3in] clear below the filter baffle for airflow.

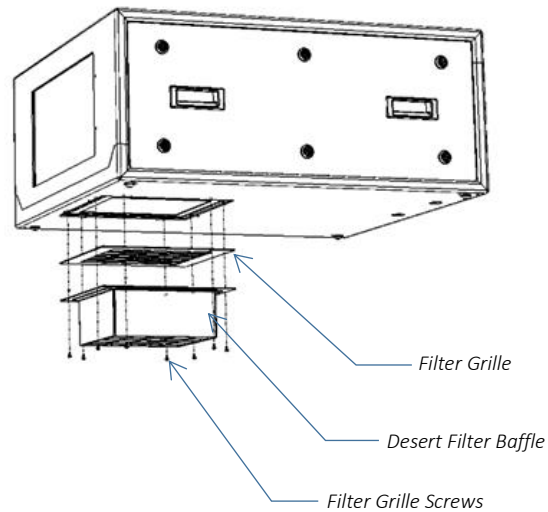
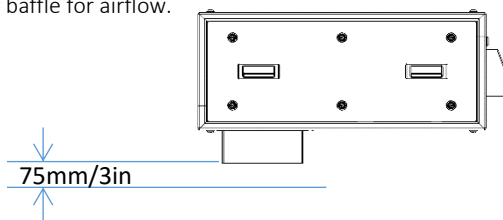

Wiring the Enclosure

Power Wiring

SAFETY NOTICE:

All electrical wiring and termination MUST be carried out by a suitably qualified and/or licensed professional, in accordance with electrical and safety norms applicable in the jurisdiction of the installation. Tempest, its employees and representatives will not be liable for any damage arising from failure to observe this requirement.

Electrical Standards

Important:

Enclosure model numbers ending **.US** are for use in countries using US and Japanese style electrical systems:

100-120VAC 50/60Hz

Enclosure model numbers ending **.IN** are for use in countries using European style electrical systems:

200-230VAC 50/60Hz

Note:

- (1) Heaters and fans are rated 115V or 230V, dependent on electrical standard.
- (2) Electronics are autosensing for any voltage 90-265VAC, 50/60Hz

Wiring Access

Open the back door, and remove the DEC4 Controller cover

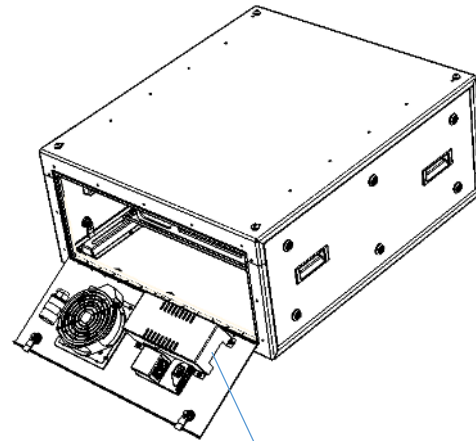

DEC4 Controller
Cover

- Fan Control Board
- RS485 Comms Board
- DEC4 Motherboard
- AC Terminal Block
- Earth/Ground Terminal
- Exhaust Fan Capacitor (positive pressure option only)
- Exhaust Fan

Duplex C13 Power Outlets – use for projector and aux equipment.

Note:

Your Blizzard enclosure comes with rewirable C14 plugs to fit these power outlets.

You MUST connect projector power to the C13 outlet. If this is not done, the controller will not sense projector function and the projector will quickly overheat.

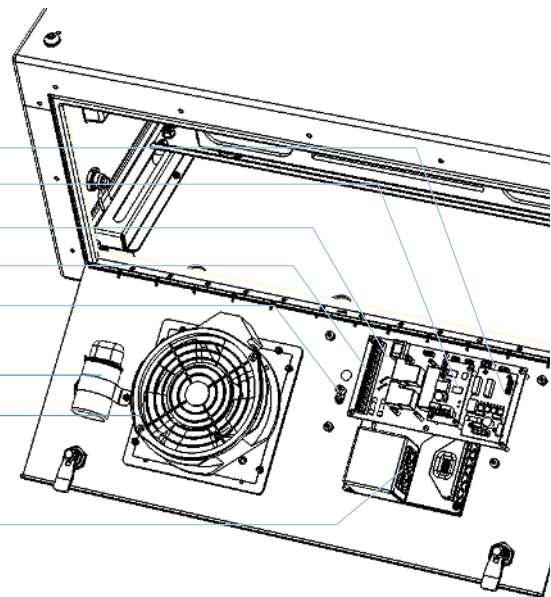

One or Two Power Circuits?

Tempest enclosures may be wired on single or double circuit supplies. On a single feed, both enclosure and projector are permanently on. With a split (double) feed supply, you can switch off the projector when not in use, while the enclosure continues to protect it 24/7.

Tip: most people use single feed.

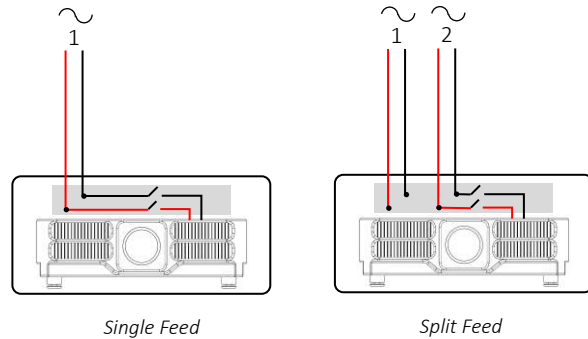

Single Feed

- Enclosure and projector are permanently on.
- Enclosure and Projector must be rated for the same voltage.
- Supply must be rated for projector current plus 150 watts.
- Supply must be permanently ON.

Split feed

- Enclosure power must be permanently ON.
- Projector power may be switched off.
- Enclosure power must be rated for 650 watts.
- Projector power must be rated for the projector (see projector manual).
- Projector and enclosure power must be same voltage.

For **single feed** wiring, no modification to the DEC4 Controller motherboard is needed.

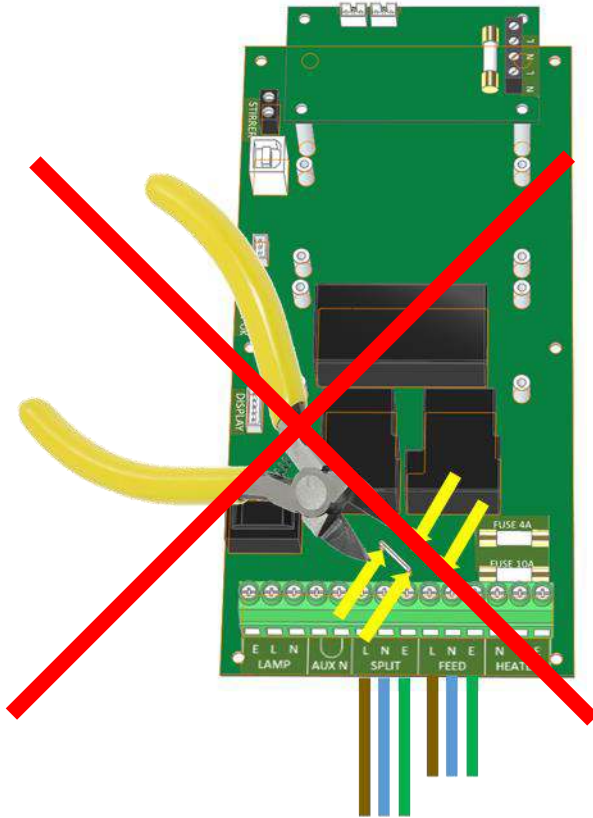

IMPORTANT:

For **split feed** wiring, use a side cutter to cut both AC links at both ends:

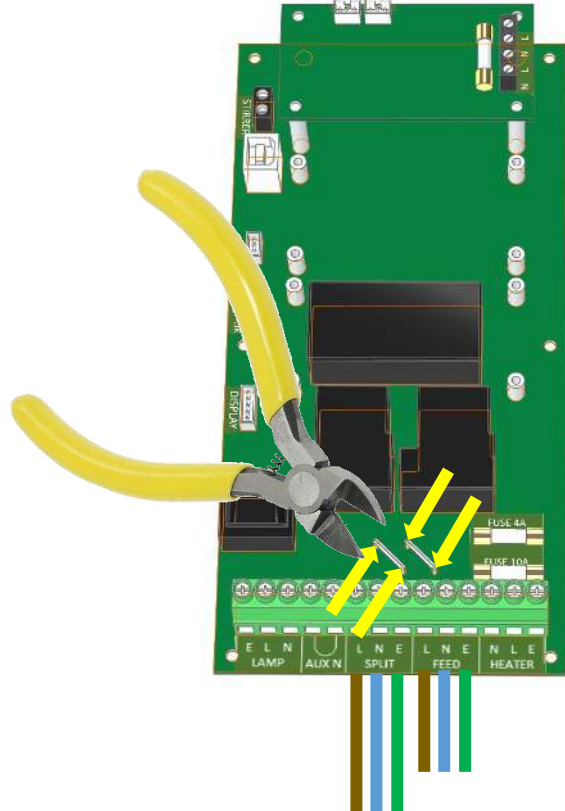

Conduit Entries

Two conduit entry holes are provided, sized for PG21 (US 3/4") conduit or cable glands. Use one for power and the other for signal cables.

DO NOT run power and signal cables through the same conduit.

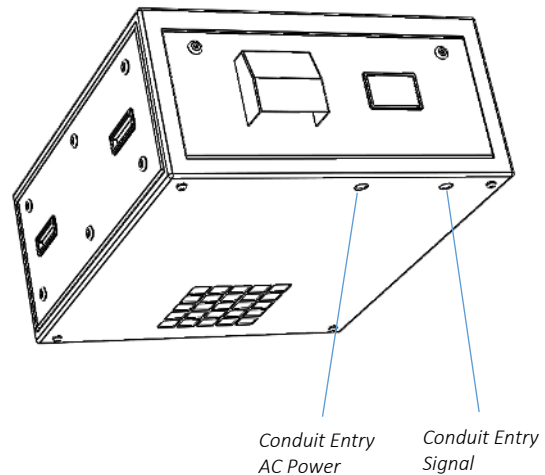

Single Feed Power Termination

- Connect Earth/Ground wire to Ground Terminal
- Connect Live and Neutral to the terminals marked FEED

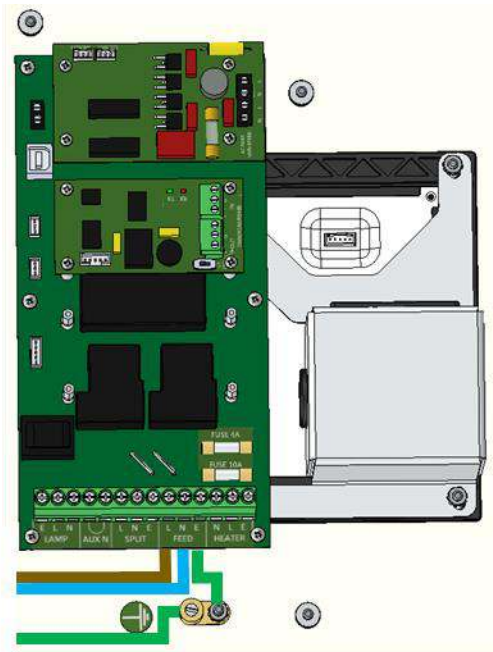

Split Feed Power Termination

- **STOP!** Did you cut the power links? See above.
- Connect Earth/Ground wire to Ground Terminal
- Connect Enclosure feed to the terminals marked FEED
- Connect Projector feed to the terminals marked SPLIT

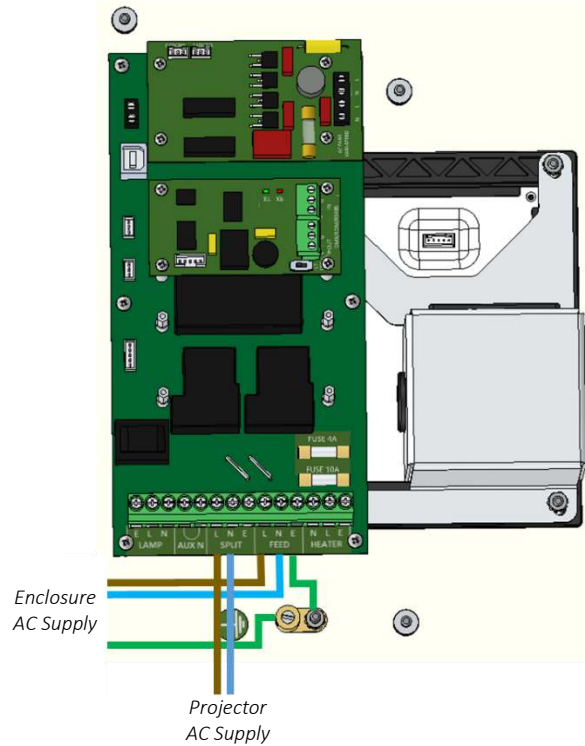

Note: Illustrations show European cable colors:

Brown = Live

Blue = Neutral

Green or green/yellow = Earth/Ground

Remote Monitoring Connections

Tempest G4 enclosures optionally support three types of remote monitoring:

1. Direct via Ethernet, using Tempest TEMP protocol.
Requires 51.EN Ethernet board
2. Grouped via RS485, using RDM
Requires one 51.485 RS485 board per enclosure (standard equipment, included)
3. Grouped via RS485, using an Ethernet bridge and Tempest TEMP protocol
Requires one 51.485 RS485 board per enclosure (standard equipment, included)

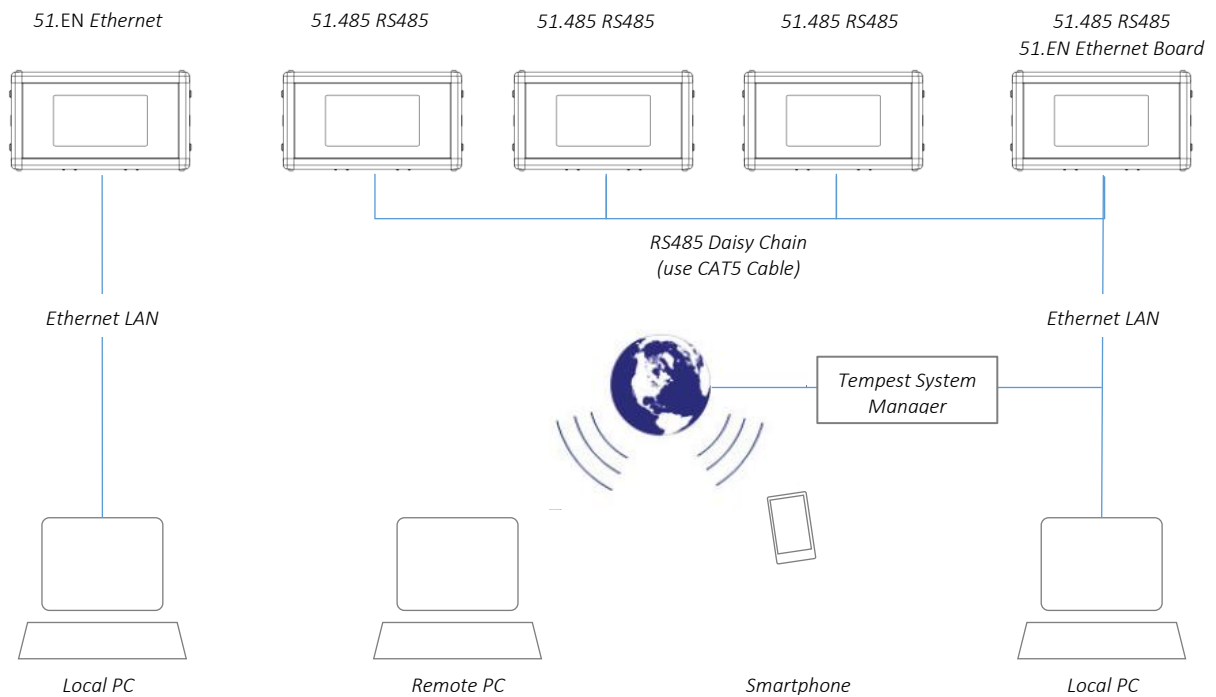

Note: Tempest System Manager and web-based monitoring are future enhancements that will be announced in due course.

RS485 (DMX/RDM) Cable Terminations

DECA System Control Board, with three typical Daughter Boards:

1. AC Fan Controller
2. Ethernet Bridge
3. RS485 Comms

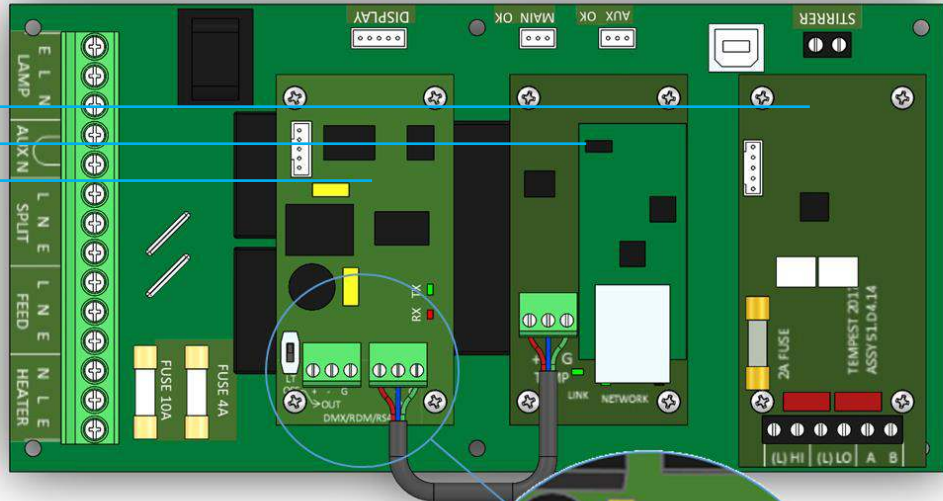

Loop a shielded twisted pair cable (eg Belden 9841, though many people now use a CAT5e cable) from the control/monitoring point, around all enclosures.

Maximum total cable length is 1,200M (4,000ft). For longer runs and wildly distributed systems, use a DMX/RDM splitter (make sure that it supports RDM) and multiple cable runs.

Use the termination switch to terminate each RS485 cable run at the last enclosure on each run.

RS485 Line Termination (LT) Switch:

TERMINATED

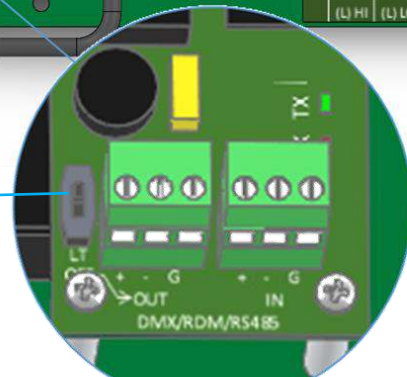

Data + Data - Common Data + Data - Common

DATA OUT DATA IN



Tempest recommends the JESE SH8 DMX/RDM Splitter for large or complex RS485 networks.

JESE RDM-TXI interface connects to a PC via USB to monitor and control a network of Tempest enclosures.
Tempest Item # 2000.195



Line Termination Switch Settings

1. DMX/RDM control over RS485:

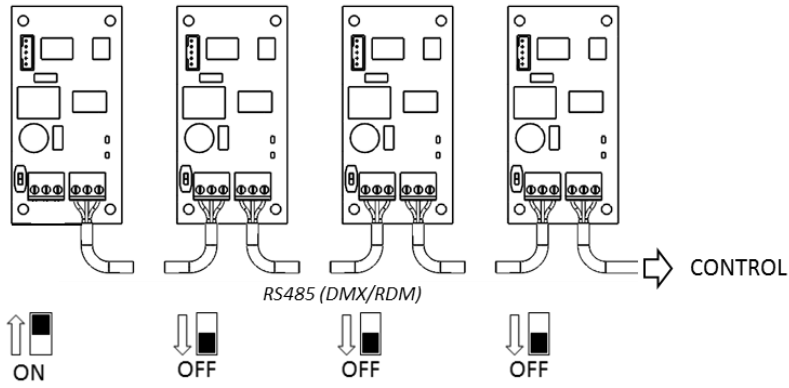

2. TEMP Control of an enclosure group via Ethernet

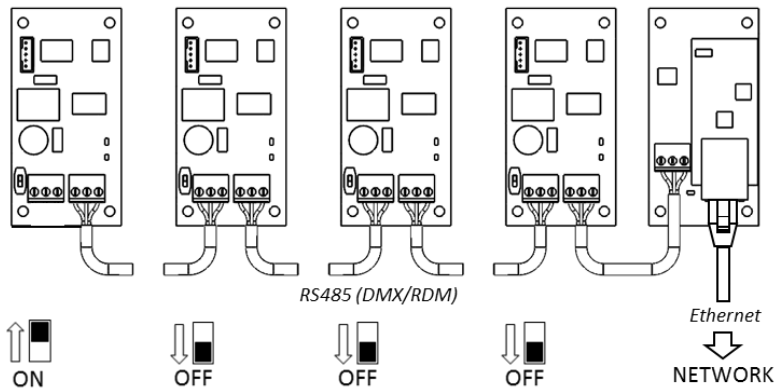

3. TEMP Control of a single enclosure via Ethernet

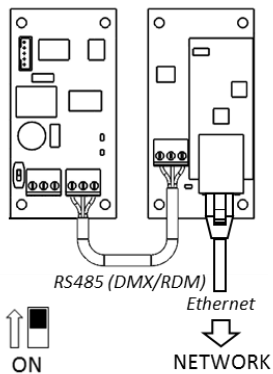

DEC4 Ethernet Adapter – 51.EN

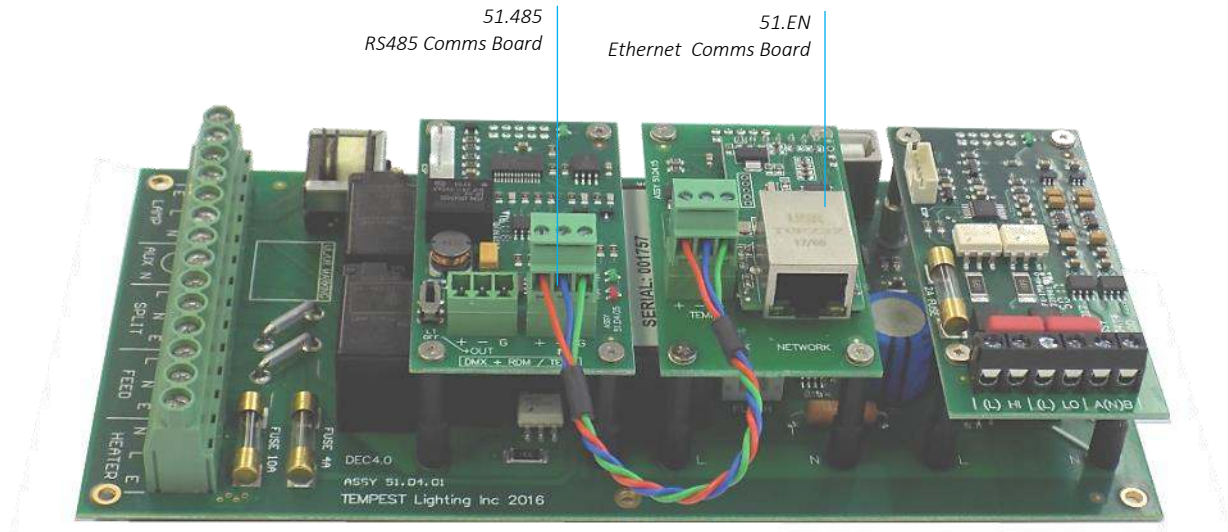

As a default, DEC4 communicates using DMX512 and RDM, over RS485.

With the addition of the 51.EN Ethernet board, any DEC4 – or any group of DEC4 boards connected using RS485 – may be connected to an Ethernet network – see above.

Default Configuration

The bridge module is supplied in DHCP TCP port server configuration, with all traffic on port 3308. These settings may be changed with a web browser on port 80 at the DHCP assigned address. Login to the home page using 'admin' for user name as password.

The bridges may be discovered with a UDP broadcast on port 1500 and a payload of

```
(Hex) 30 31 32 33 34 35 36 37 38 39 30 31 32 33 34 35 36 37 38 39
      30 31 32 33 34 35 36 37 38 39 30 31 32 33 34 35 36 37 38 39
```

The bridge will respond from its DHCP address

Additional Support

The network IP is developed by Jinan USR, more details and software configuration utilities may be found by visiting their web site at <https://www.usriot.com>

Tempest Equipment Management Protocol

TEMP allows you to access status information and set configuration values on DEC3.3 and DEC 4 enclosure controllers, using the 51.EN Ethernet Adapter, over an Ethernet network.

Download the Developer Guide at
www.tempest.biz/tech_support

IMPORTANT:

Tempest warrants that, if correctly implemented, TEMP will provide a reliable and accurate method of monitoring Tempest DEC3 and 4 controllers over an Ethernet network. However, the integrator is entirely responsible for the connection between the Ethernet Bridge and the network.

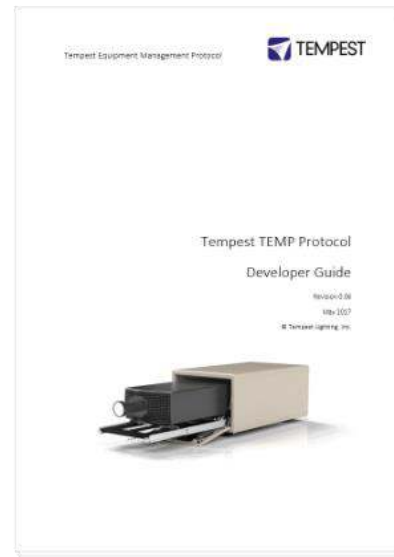

Projector Power Control using DMX512

The DEC4 controller includes a 30A 2-pole relay that protects the enclosed equipment in the event of a serious high temperature event by cutting off power. In 3-phase enclosures this is augmented by a 4-pole contactor.

You may use DMX512 (a popular entertainment industry protocol running on RS485, originally intended to control lighting system dimmers) to control power to the projector inside the enclosure. This is very useful in hot locations, where the projector may be stressed by being held in standby mode all day under hot sun. By powering the projector down it will tolerate much higher temperatures without harm.

Tempest recommends the JESE RDM-TRI interface to monitor enclosure status in any installation and control the enclosure power relay in smaller systems.

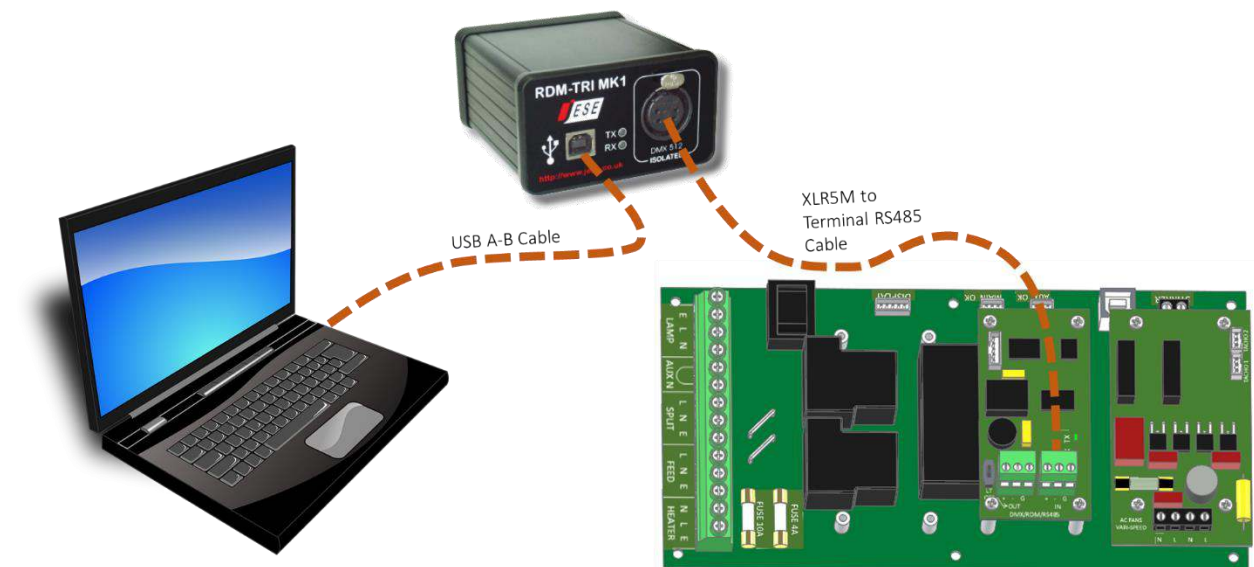
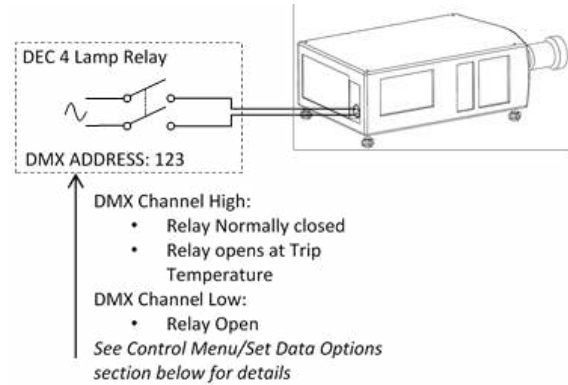

More complex installations are very likely to include some kind of show control system that will certainly include DMX control. This is the preferred method of controlling power to the projectors.

DMX/RDM Network, using JESE RDM-TRI

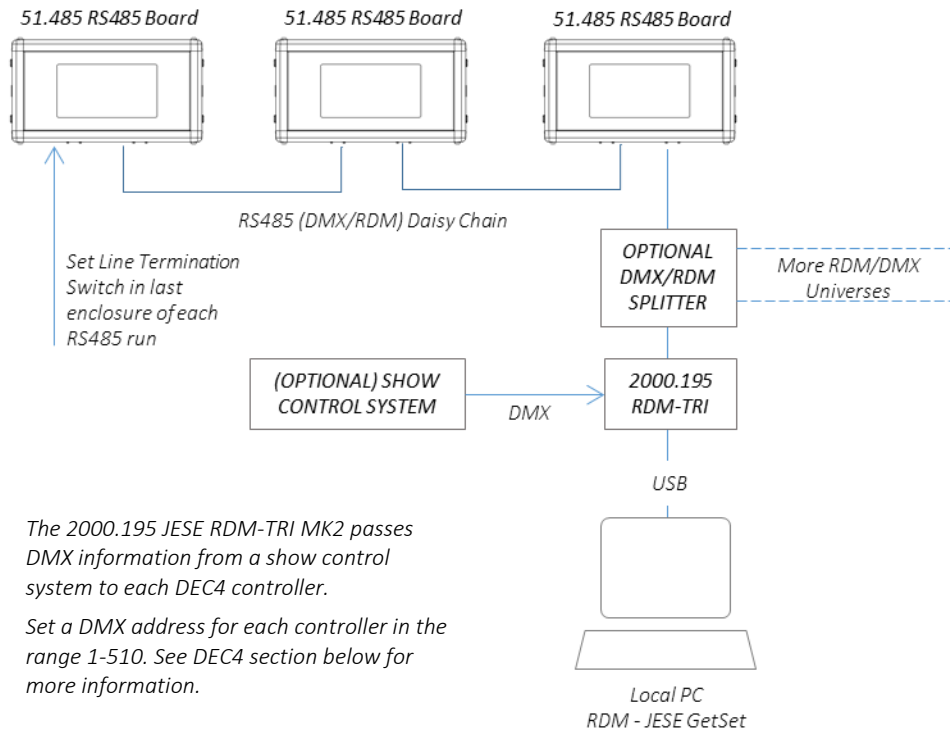

The 2000.195 JESE RDM-TRI MK2 passes DMX information from a show control system to each DEC4 controller.

Set a DMX address for each controller in the range 1-510. See DEC4 section below for more information.

Positive Pressure Fan Control Option

When the Positive Pressure (51.PP) option is ordered, the enclosure fan function is changed.

- Normally the enclosure fan(s) will run only when either the projector/luminaire lamp is on, or if the daytime temperature in the enclosure exceeds the DEC Upper Temperature setting. At all other times the fan is OFF.
- With the Positive Pressure option, when the fan would normally be off, it is instead powered via a capacitor that lowers the operating voltage so that the fan continues to run at a low level, maintaining positive pressure in the enclosure and preventing harmful contaminants from entering through the exhaust path.

Fan Control Board

Capacitor

Fan

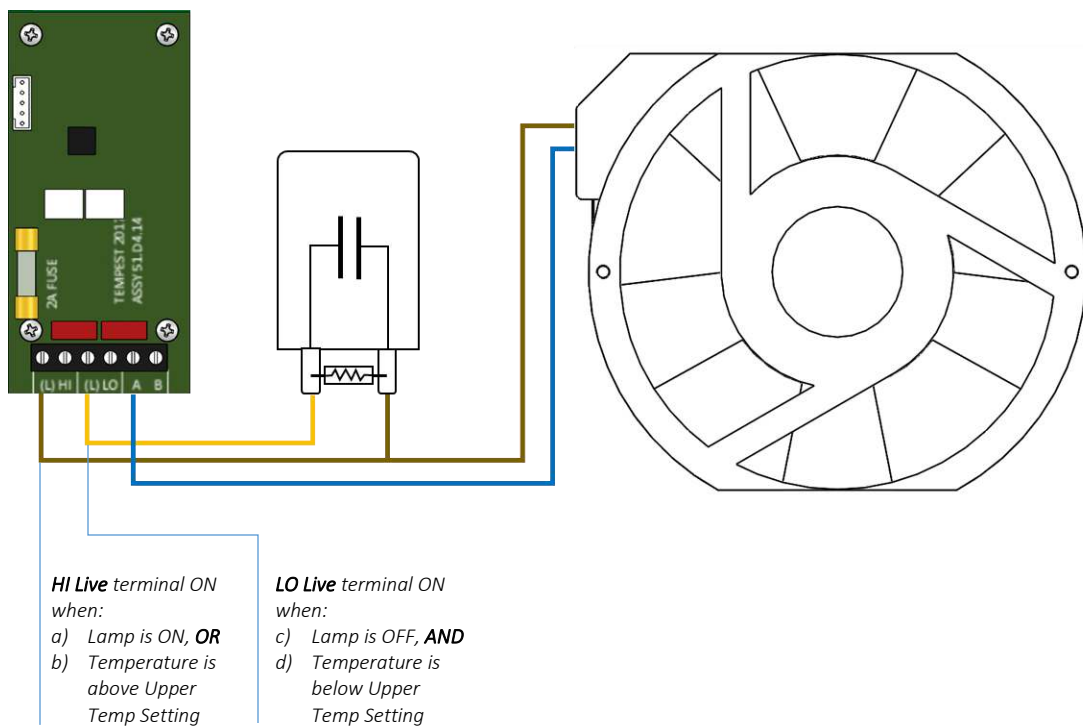

Mounting the Projector

Landscape & Portrait Enclosures – fixed or slide? Tabletop or ceiling?

Projector Fixed or Slide Mounting

Blizzard portrait and landscape enclosures are available with either fixed or sliding projector mounts.

Fixed or Slide is designated by the 7th digit in the model number, eg:

52.100.L**F**.US Fixed projector mount

52.150.P**S**.IN Sliding projector mount

Using either Fixed or Slide mounts, you can access the projector from either side, and also from the back, for relamping rear-access models without disturbing projector lineup.

You may configure projector slide mounts to slide out of either the right or left side – see below.

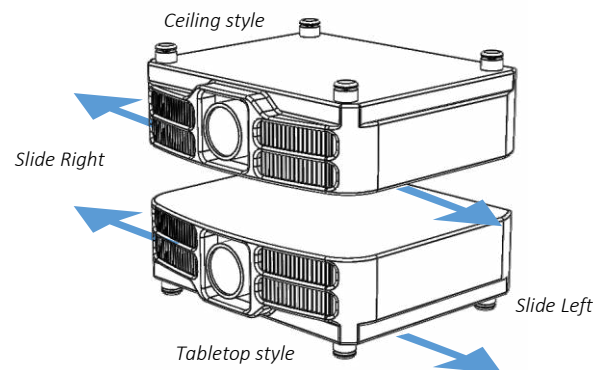

Ceiling or Tabletop

Blizzard enclosures are configured as standard for tabletop operation (feet down).

Ceiling (feet up) configuration is a factory option – please specify when ordering.

Projector Slide Direction

Blizzards with the Projector Slide option ship from the factory configured for tabletop operation, left slide – shown here...

If that is what you need, skip the next section.

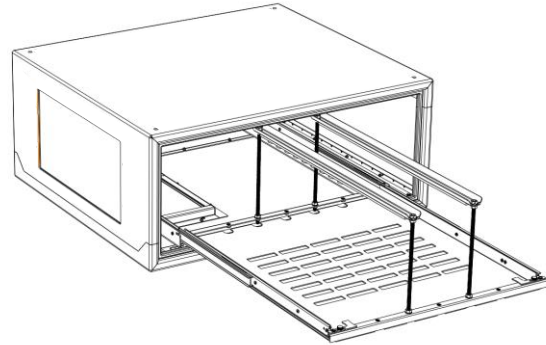

*Projector Slide Mount, **Tabletop/Left Slide** factory default configuration*

Reversing Slide Direction

To switch to Right Slide:

1. Remove the slide latch knobs and flip the slide latches back, as shown here. This gives access to the projector bridge clamp screws
2. Using a #2 Philips screwdriver, loosen the projector bridge clamp screws until they are no longer engaged in the projector bridge clamps.
3. Repeat on the other side of the slide assembly until all eight screws are free.
4. Lift out the slide tray assembly, turn it around so that the slide latches are on the right side, and replace.
5. Re-engage the eight projector bridge clamp screws and tighten (use a small screwdriver to align the projector bridge clamps if you need to).
6. Replace the slides and slide latch knobs.

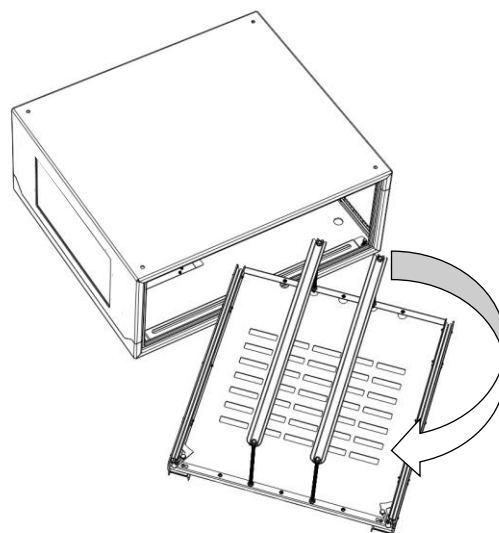
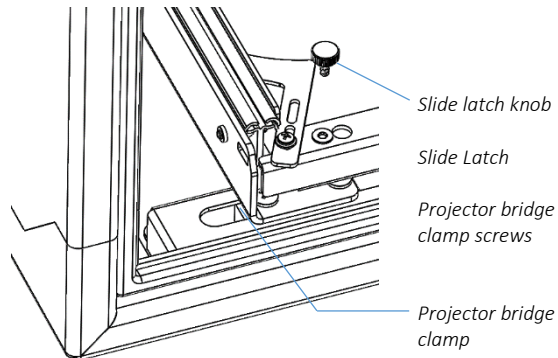

Mount the Projector – Fixed Mount

Fine for most applications, fixed mounts hold the projector firmly in place, while allowing access from either side and from the back for alignment, service and lamp changes.

Tabletop Installation

1. Loosen the Bridge Clamp Screws both sides
2. Slide the projector bridges to align with projector feet, and re-tighten the bridge clamp screws.
3. Remove the projector rods nearest you, by loosening the rod nuts and unscrewing from the projector bridges.
4. Slide the projector along the projector bridges so that it is roughly centered in the enclosure
5. Replace the projector rods nearest you.
6. Align the projector, using the projector feet to adjust tilt and roll.
7. When projector alignment is complete, lower the projector bails and secure firmly in place by tightening projector rod nuts.

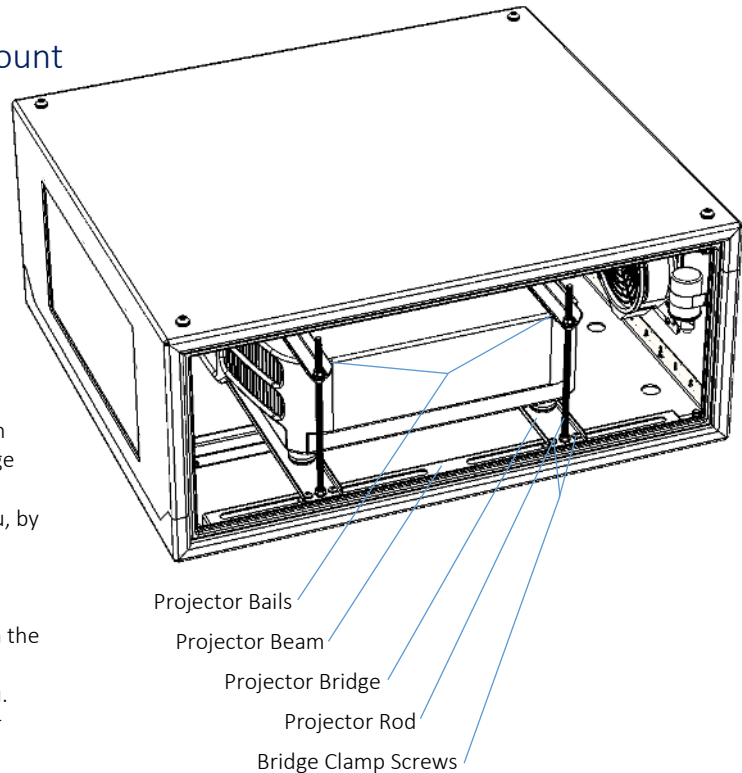

Mount the Projector – Slide Mounts

- (1) Slide Mount: slide out the projector tray and set the projector in place
- (2) Adjust the projector bails for a loose fit (you will adjust and lock down later)

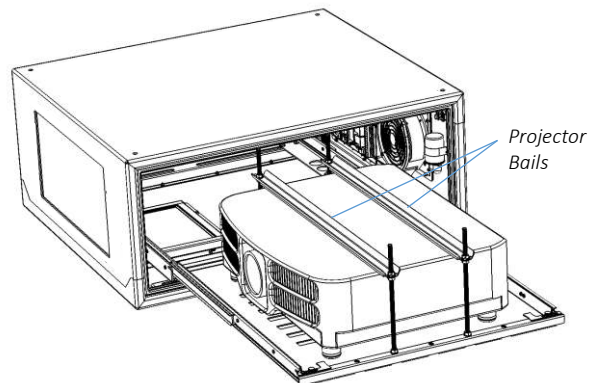

- (3) Slide the projector back into the enclosure

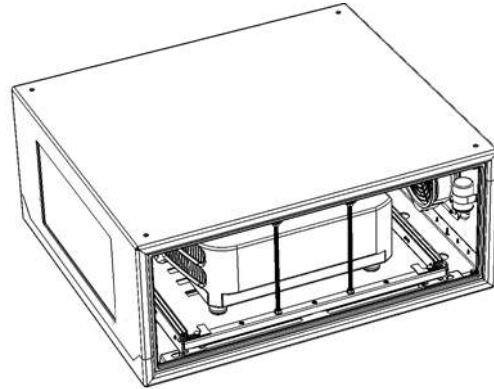

- (4) Secure the projector tray latches and tighten the latch knobs

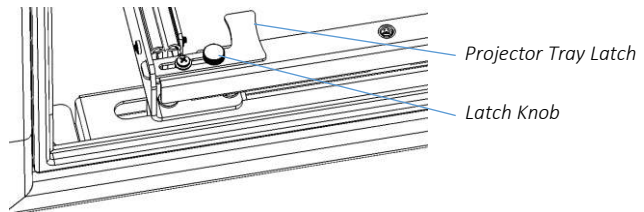

- (5) Plug the projector power cable into one of the IEC C13 outlets provided. THE PROJECTOR MUST BE POWERED THROUGH THE DEC.
- (6) The second outlet is available for any auxiliary equipment that may be housed inside the enclosure.

Note that two IEC C14 plugs are provided with the Blizzard enclosure for your convenience.

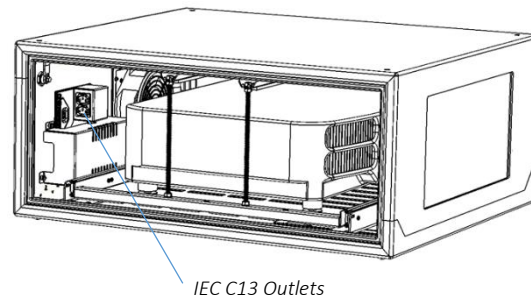

Aligning and Securing the Projector

- (1) Use the projector's feet to adjust projector alignment.
- (2) Tighten Projector bails to secure projector in place.

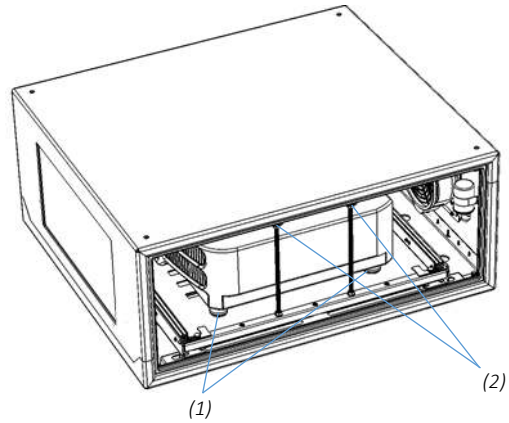

Projector Mount – Portrait

Blizzard Portrait enclosures now come with a universal projector mounting system that will firmly support any suitable projector with threaded holes in the projector base.

A pair of sliding projector bars may be positioned, either straight or at an angle, so that four mounting points may be accessed on any projector.

The illustration here shows the portrait slide mount, but the slide and fixed mounts work the same.

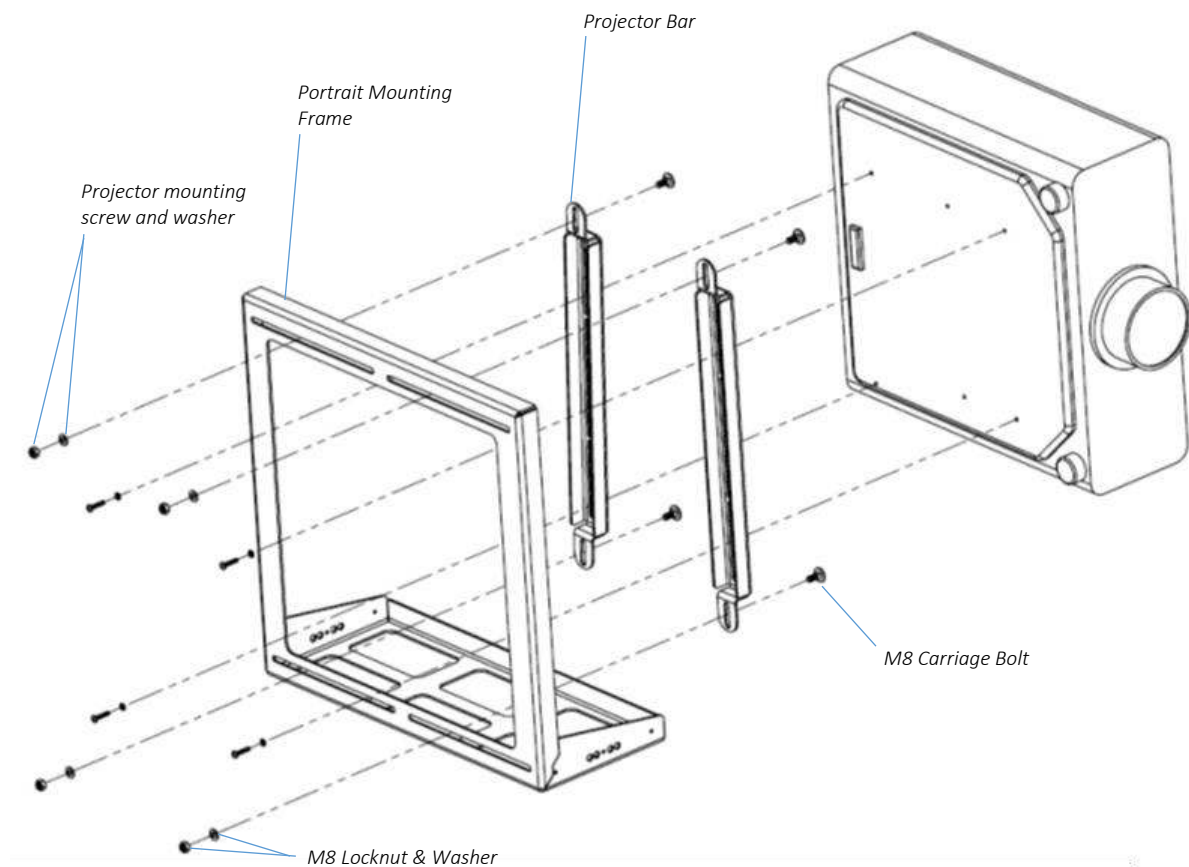
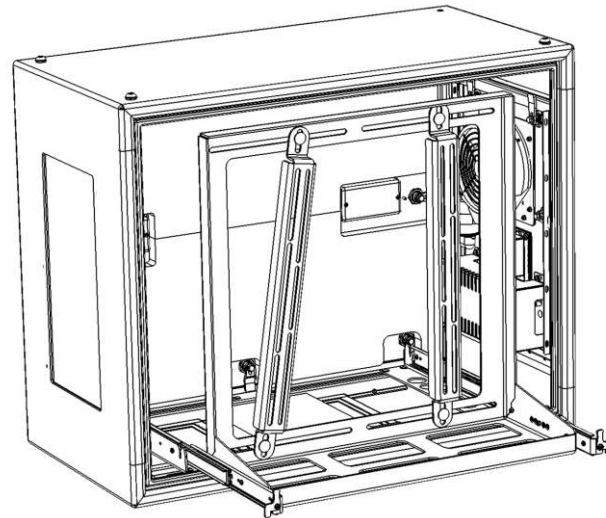

For clarity, the portrait mounting frame is shown outside the enclosure

Changing Portrait Orientation

Some projectors may only be used in portrait mode in one orientation (feet left or feet right).

It is easy to change the orientation, by rotating the portrait mount assembly (fixed or slide) 180 degrees.

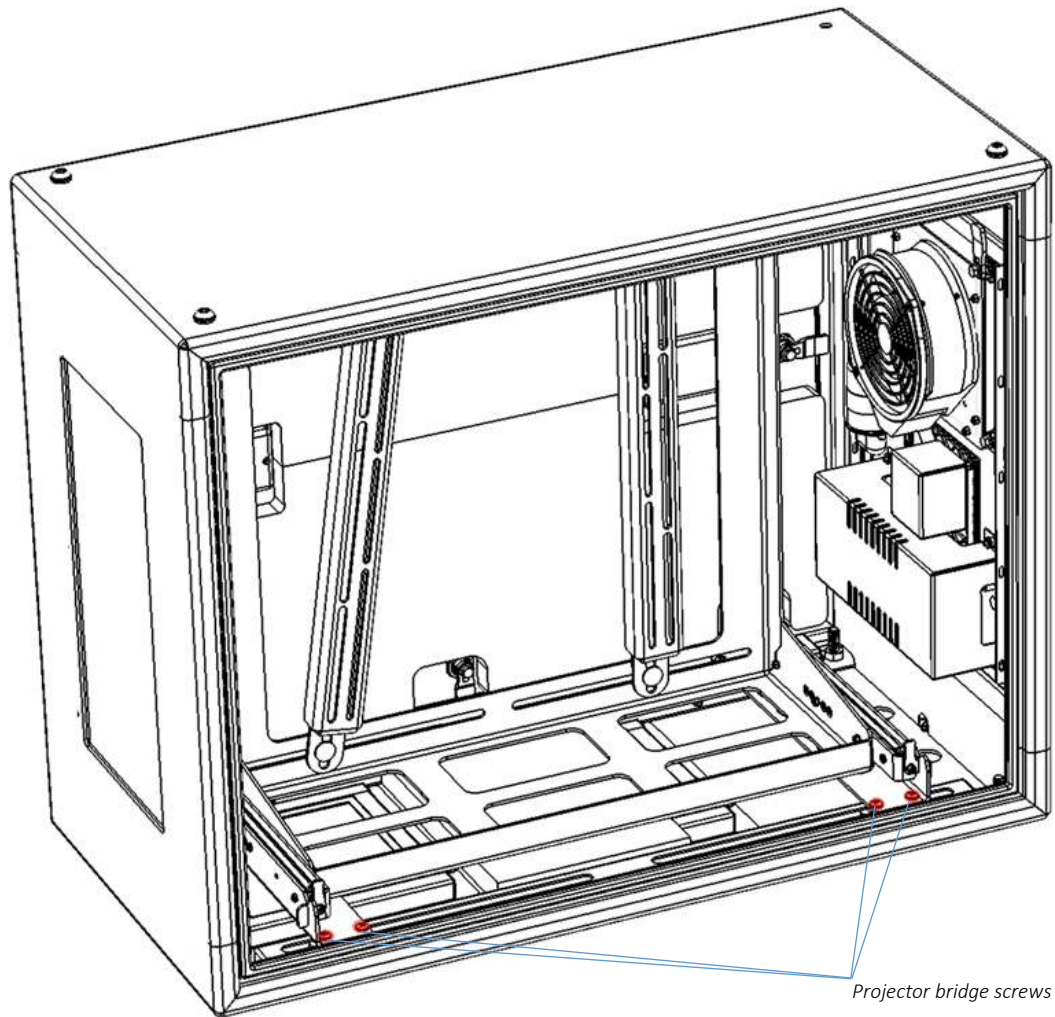

1. Remove the eight projector bridge screws (4 each side)
2. Rotate the projector mount assembly 180°
3. Replace the projector bridge screws

Projector Mount – Ultra-Short-Throw

Short-throw projector mounts are fixed, and are not adjustable. This is to ensure that the beam envelope is correctly maintained within the boundaries of the port glass.

Like portrait enclosures, Blizzard UST enclosures are customized to suit the projector specified by the user.

1. Remove the two safety knobs
2. Loosen (do not remove) the four mounting bolts
3. Slide the mounting tray forward (away from the cover hinge) and remove.
4. Attach the projector to the mounting plate, using the screws provided
5. Lift the mounting plate and projector into the enclosure base, locate the keyholes on the mounting plate screw heads, and slide the projector towards the cover hinge.
6. Tighten all mounting bolts.
7. Insert the two safety knobs and tighten.

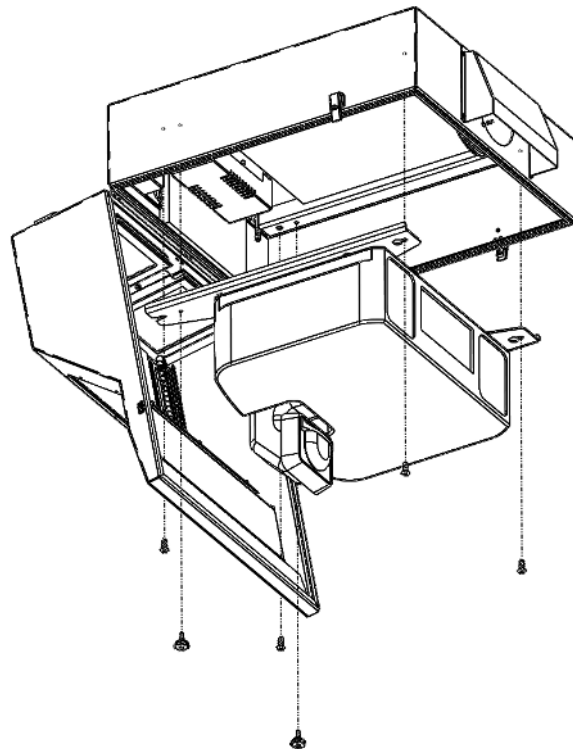
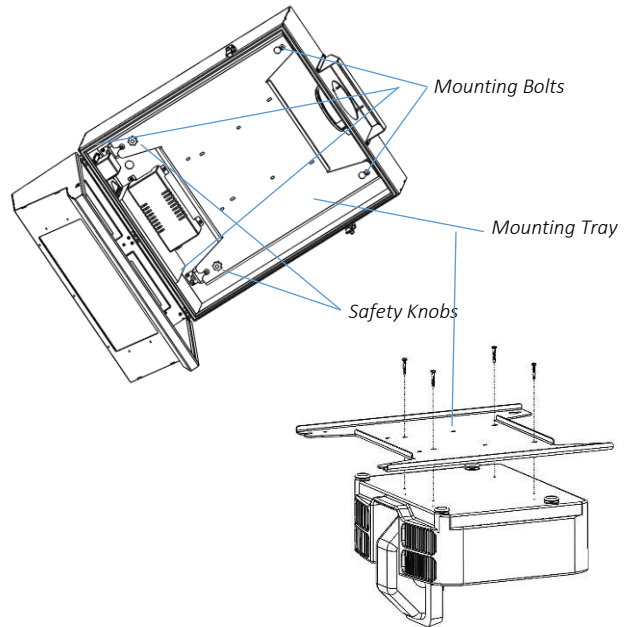

Digital Enclosure Control

DEC4™ – that’s Digital Enclosure Control, fourth Generation – is the brain of your Tempest enclosure. It will maintain the internal environment in a comfortable temperature and humidity range, and prevent condensation – the real killer of outdoor equipment. DEC4 monitors internal and external temperature, humidity and lamp current at all times, and uses this information to control the enclosure’s lamp relay, fan(s) and heater(s). It can report back over an RS485 network, using the RDM protocol (Remote Device Management), or connect to your TCP/IP network for remote monitoring and management using Tempest’s TEMP protocol.

Typical DEC4 configuration, with Motherboard, fan control board and RS485 comms board

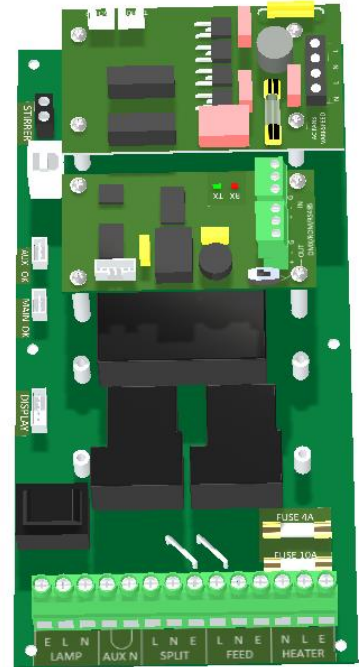

Schematic

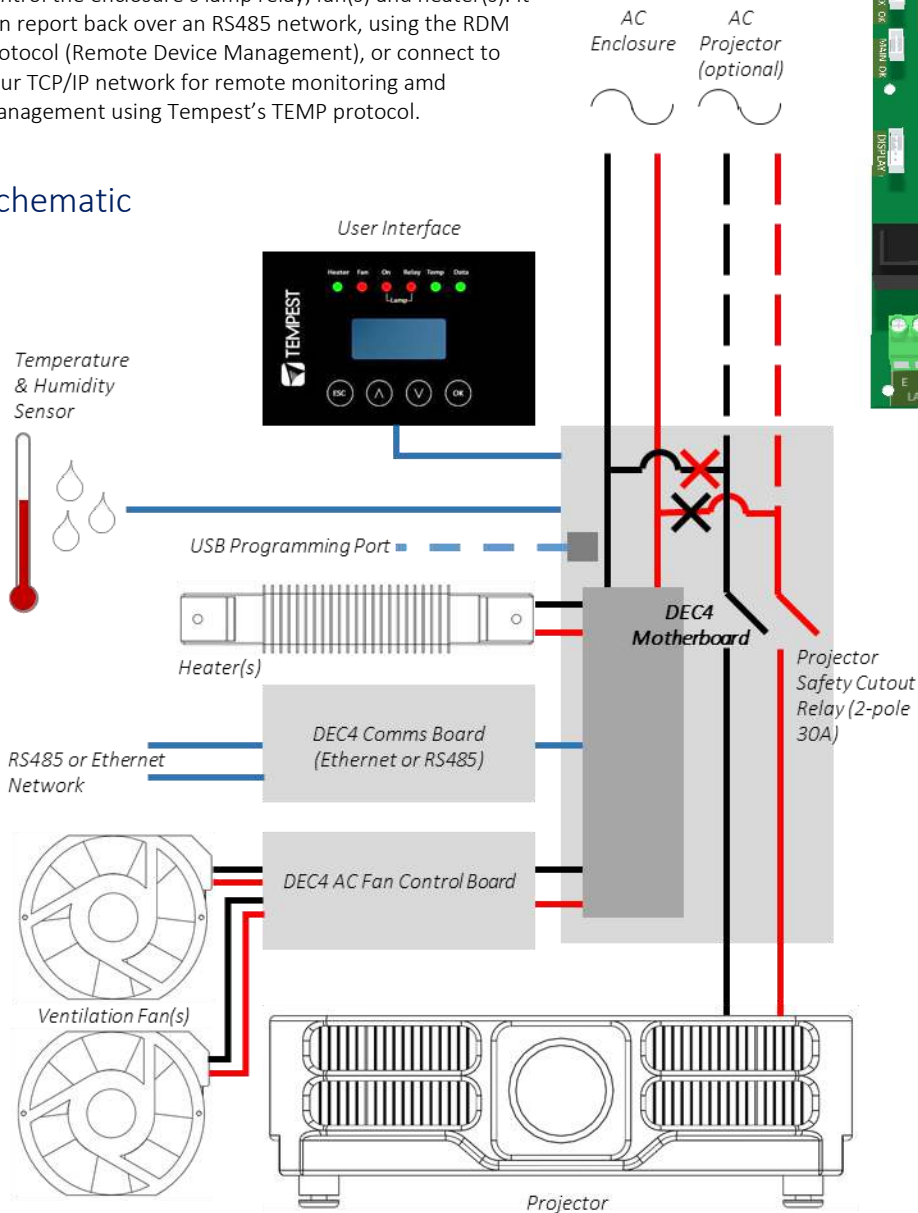

DEC4 Main Functions

Firmware Revision

This manual covers DEC4 Firmware revision 2.03.000 and higher.

To check the Firmware revision, on the User Interface menu, go to Status Display/Firmware.

1. Sense current to projector (lamp on/off)
2. Record lamp hours
3. Monitor temperature and relative humidity inside Enclosure
4. Monitor temperature outside enclosure
5. Maintain internal temperature at safe operating level
6. Maintain relative humidity within safe limits to prevent condensation
7. Isolate projector in case of unsafe temperature
8. Report status over RS485, RDM, TCP/IP
9. Maintain positive pressure (optional) 24/7 to prevent ingress of salt air and other contaminants through the exhaust path
10. Circulates air internally to prevent hot and cold spots when projector is idle

DEC 3.3's patented Goldilocks™ algorithm uses a combination of sensors, heaters and fans to maintain a safe operating temperature and a safe relative humidity level that will not allow condensation to take place.

As air is heated it is able to support more moisture without condensing, so Goldilocks uses heat to raise the air temperature inside the enclosure in the event that relative humidity approaches dewpoint.

DEC4 constantly monitors the following parameters:

- Projector/Luminaire current
- Line Voltage
- External Temperature
- Internal Temperature
- Internal Relative Humidity

Factory Settings – Data Modes

In most applications, DEC4 will operate correctly with its factory default settings, in Basic operating mode.

You do not need to do anything. Please skip to the next section.

- Standard default temperature and humidity settings
- DMX, RDM and Remote Monitoring disabled
- Best for standalone operation

If your needs are more complex, read on.



Hardware Indicators & Fuses

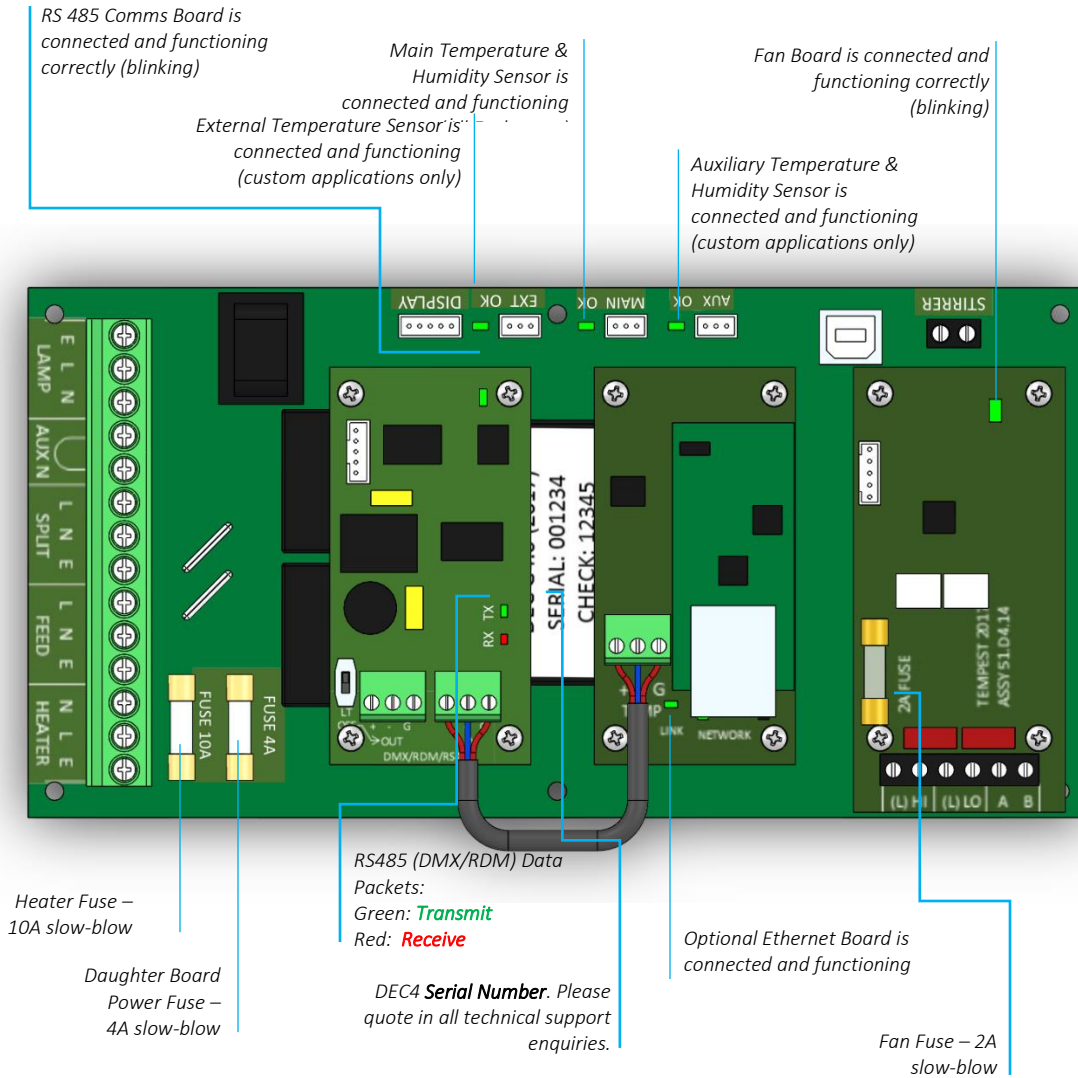

Operating Modes

RDM Only Monitor (Factory Default)

- Supports RDM monitoring over RS485 if present
- Supports TEMP monitoring if present
- RDM Status Reporting over RS485
- RDM Configuration – settings may be changed remotely or at the enclosure user interface.
- No DMX control

RDM+DMX Control

- Enclosure functions as a 1-channel DMX device, with remote control of the lamp relay
 - DMX level > 75% enables normal relay operation (normally ON)
 - DMX level < 25% disables normal relay operation (relay turns OFF)
 - This allows you to force a hard reset of the lamp relay in the event of a projector malfunction
- RDM Status Reporting over RS485
- RDM Configuration – settings may be changed remotely or at the enclosure user interface.
- Control mode is recommended for show control applications, but can be risky in live show operation, since the DMX slot used for the enclosure MUST be kept high to prevent the lamp relay from opening.

RDM+DMX Service

For trained service personnel only

- Normal operation is suspended and the enclosure functions as a 3-channel DMX device:
 - Lamp Relay (Slot 1)
 - Fans (Slot 2)
 - Heater (Slot 3)
- RDM Status Reporting over RS485
- RDM Configuration – settings may be changed remotely or at the enclosure user interface.
- ***Service mode is ONLY for troubleshooting – DO NOT use Service mode for normal operation.***

DEC4 Control Parameters

Temperature and Humidity Ranges

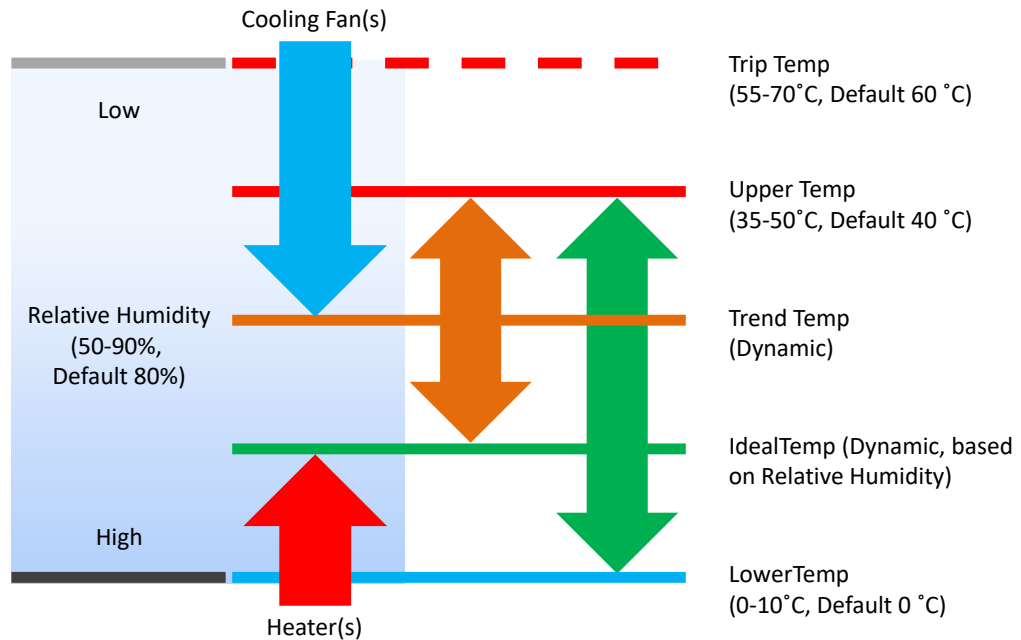

Notes:

- 1 In moving light enclosures the temperature sensor is located in the exhaust airflow. Temperatures shown may be higher than those around the projector.
- 2 We recommend using the factory default settings for several weeks or months before making any changes. In most cases they will not be necessary.

Control Interface

LED Indicators

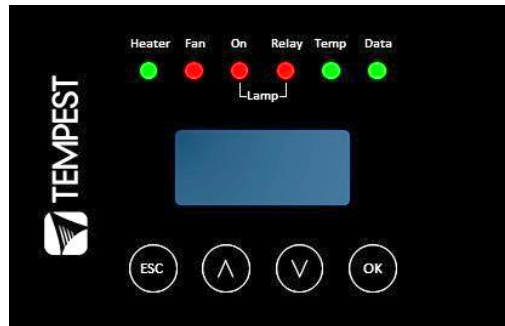

Heater	ON (Green)	Heater is ON, to maintain lower temperature level or to prevent condensation
	ON (Amber)	Enclosure is temporarily outside the Goldilocks zone, and DEC is working to restore it
Fan	ON (Green)	Lamp is ON, or Temperature is HIGH and fan is cooling enclosure. Short burst when lamp off indicates fan moving air to stabilize temp/humidity. <i>NOTE: Fan LED will not light if no fan is detected</i>
	Lamp On	Current sensing shows lamp is ON Lamp hour counter is running
Lamp Relay	OFF	Current sensing shows lamp is OFF Lamp hour counter is not running
	ON (Green)	Lamp relay is closed (normal) Projector power receptacle is energized
	ON (Red)	Lamp relay is open due to over-temperature event. Projector power receptacle is isolated.
Temp	FLASHING (Green)	Temperature is below lower temp setting
	ON (Green)	Temperature is in normal range
	ON (Amber)	Humidity is above target limit
	ON (Red)	Temperature is above top setting
	FLASHING (Red)	Temperature is above Trip level Projector power is isolated
Data	OFF	Data not used in present Mode. OR DEC4 is in RDM + DMX Control Mode and no valid data packet has been detected.
	ON (GREEN)	Good data packet received.
	ON (RED)	RDM + DMX Control Mode: Data Fail. A previously good data signal has failed.

User Interface LCD Display

The display on the Control display provides additional status information, depending on the operating mode:

RDM Only Monitor Mode

28 °C	47%	<i>internal temperature, relative humidity line voltage, lamp status</i>
209V	OFF	

RDM+DMX Control Mode RDM+DMX Service Mode

28 °C	47%	<i>internal temperature, relative humidity line voltage, lamp status</i>
209V	OFF	

Alternating with:

DMX: 001	<i>DMX Start Address DMX Status</i>
No DMX	

(Alternating DMX Display requires a DMX signal to be present)

Control Interface Operation

The Control Interface is normally LOCKED.

- To UNLOCK, hold **ESC** and **OK** together for **5 seconds**.
- You are now in the CONTROL MENU
- Use **↑↓** to scroll up and down the menu.
- Press **OK** to enter a menu item
- Use **↑↓** to set the item parameter, or to scroll to the next menu level.
- Use **ESC** to go BACK, or **OK** to confirm settings (**↵**).
- To exit and LOCK, hold **ESC** for 5 seconds.

Menu will time out and the display will lock after ten minutes.

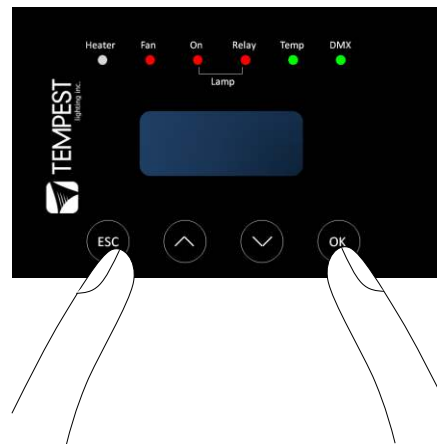

Control Menu

Set Data Options

SET DATA MODE

From the Front Panel, this menu item allows the user to check (and if necessary change) the Data mode.

RDM Only Monitor	DEFAULT	Supports RDM or TEMP if connected. No DMX Control.
RDM+DMX Service		Service mode – 3 DMX slots, starting with the DMX address set <i>Important: Please ensure that DEC4 is NOT left in Service Mode.</i>
RDM+DMX Control		DMX (set 1 address for lamp relay) plus RDM

SET DATA ADDRESS (in RDM Only Monitor, RDM+DMX Service or RDM+DMX Control Service modes)

Select a DMX starting address in the range 001 to 510

1 – Lamp Relay

In Service Mode an addition two slots are available

2 – Fan Duty Control

3 – Heater Duty Control

Note that the DMX control is designed using a SAFETY pile-on Logic. So the DMX input can only override automatic settings within safe limits.

SET DATA CURVE

DMX Curves affect the way the fixture relay is controlled in RDM+DMX Control Mode.

DMX levels are shown as %.

Response Curve 1 (default)

DMX level 0-25 Relay disabled (open)

DMX level 26-75 No change to relay status

DMX level 76-100 Relay enabled (normally closed)

Response Curve 2

DMX level 0-19 No change to relay status

DMX level 20-40 Relay disabled (open)

DMX level 41-59 No change to relay status

DMX level 60-80 Relay enabled (normally closed)

DMX level 81-100 No change to relay status

SET DATA RESPONSE

DMX Response sets a delay time before DMX Control Mode settings are acted on. Setting a response delay of a few seconds would prevent unintended fixture relay state changes in the event of a short accidental change in DMX level.

NOTE: from firmware revision 0.00.100, DEC holds last valid DMX level if DMX is interrupted.

Response Delay Values are:

No Delay (default), 1, 2, 5, 10, 15, 20, 30, 60 seconds.

Set Temp Units

Choose to display temperature values in Celsius or Fahrenheit (default Celsius)

Note that temperature settings must be entered in Celsius.

Set Temp Ranges

Set three temperature trigger points for Bottom, Top and Trip temperatures, in °C.

SET TEMP LOWER (minimum temperature to be maintained)

(default 10°C, permissible range 0-10°C).

SET TEMP UPPER (maximum desired daytime temperature)

(default 45°C, permissible range 35-50°C).

SET TEMP TRIP (temperature at which load will be isolated – see note)

(default 60°C, permissible range 55-70°C).

Note: A thermal emergency is when enclosure ventilation fails with the lamp on, in which case the temperature will rise very quickly. To avoid nuisance tripping we recommend setting a higher Trip temperature, 60°C or above.

Set Max Humidity

Sets highest desired Relative Humidity: Default 85%, permissible range 80-90%.

Note that, when the projector/luminaire lamp is OFF, the enclosure heaters will switch on to raise the temperature and lower the risk of condensation. We recommend setting the highest Max Humidity that works in your location, to avoid unnecessary heater use.

Set Lamp On Point

The lamp current at which DEC detects the projector/luminaire lamp is running. Default is 1 Amp, which allows for most equipment fans and power supplies to run without changing the air in the enclosure. Lamp on point may be set in 0.1 Amp increments between 0.2 Amps and 2.0 Amps.

If the enclosure fans never turn off, the Lamp On point is probably set below the standby current draw of the projector/luminaire. Check the standby current draw on the display and set the Lamp on Current higher.

Reset Lamp Hours

Reset each time you change the lamp in the projector.

Make this a part of your maintenance instructions.

Set Fan Function

SET FAN TEST

To test the enclosure fan(s), press [OK]

The enclosure fan will run

The Display Fan LED lights green

DEC Beeps

To stop the fan test, press [ESC]

Status Display

View current status information, using the arrow keys to scroll through:

- a) Humidity – relative humidity in %
- b) Internal temperature, in degrees C or F
- c) External Temperature (custom enclosures with external temperature sensors only)
- d) PCB temperature (this will usually be significantly higher than air temperature)
- e) Voltage – line Voltage reaching the DEC
- f) Current being drawn by projector/light, in Amps
- g) Lamp Hours elapsed since last reset
- h) Firmware version
- i) UID – unique system ID number

Safe Mode

In certain circumstances, the DEC User Interface may display the message SAFE MODE. This can happen if the Humidity sensor stops reporting, or reports an extreme value, indicating the probability of a sensor error. This situation may arise either because of a faulty sensor* or in conditions of extremely high absolute humidity.



In SAFE MODE, the normal Goldilocks operation is temporarily suspended, and the enclosure works to return the internal environment to a condition from which normal operation may be resumed.

SAFE MODE is SAFE! It indicates that attention may be needed, but not that your equipment is at risk.

** Some sensors shipped before mid-2017 have had a limited operational life in harsher conditions. Tempest has since developed a new class of capacitive sensor that is far more resilient, especially in demanding conditions.*

The new class of sensors (MG Type) have either:

- a) A piece of green tape on the sensor cable

And/or

- b) TEMPEST logo on the plastic sensor case

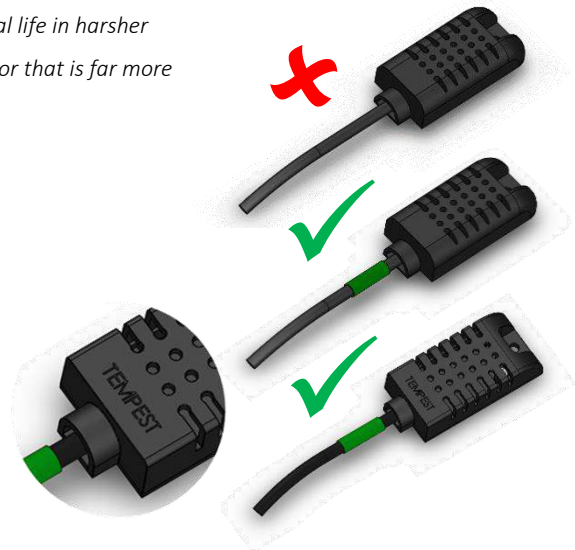

Safe Mode – What to do:

If you see **SAFE MODE** on your User Interface Display:

1. Check the temperature/humidity sensor:
 - a. If it does NOT have either a Tempest logo or a piece of green tape on the cable, contact Tempest for a free-of-charge replacement. If you have more than one enclosure, we suggest replacing the sensors on ALL your enclosures.
2. If the sensor has either a Tempest logo or a piece of green tape on the cable, then:

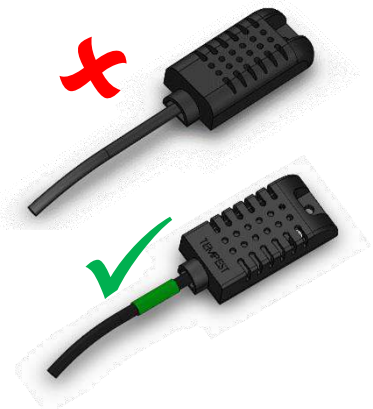

- a. Check that the sensor cable is not damaged and that it is plugged in to the header on the DEC Mother board labeled MAIN
- b. Check the actual climate conditions – could the absolute humidity be close to 100%? If it is, SAFE MODE is operating correctly, and all is well.



DEC4 Firmware Updates

From time to time Tempest may introduce new DEC4 firmware for feature enhancements and bug fixes. Please note that the main System Control Board (SCB) and the various optional daughter boards each have their own firmware, and it will be good practice to update all firmware in an enclosure for optimal performance and interoperability.

- System Control Board firmware may be updated DIRECTLY using JESE JUST software and a USB cable, or INDIRECTLY, over an RDM network, using JESE GetSet software and a JESE RDM-TRI interface.
- Fan board firmware is extremely simple and is unlikely to require updating.
- RS485 Board (51.485) firmware may be updated over an RDM network, using JESE GetSet software and a JESE RDM-TRI interface.

All required files are available for download at <http://www.tempest.biz/tech-support.php?lang=en>

Indirect Firmware Updates

Requirements

Windows Laptop / PC, Windows XP through Windows 10

A JESE RDM-TRI or RDM-TXI interface and USB connection (available from Tempest).

An installed version of the JESE GetSet RDM configuration utility.

A copy of the firmware file(s) to upload, available for download from www.tempest.biz/tech_support.

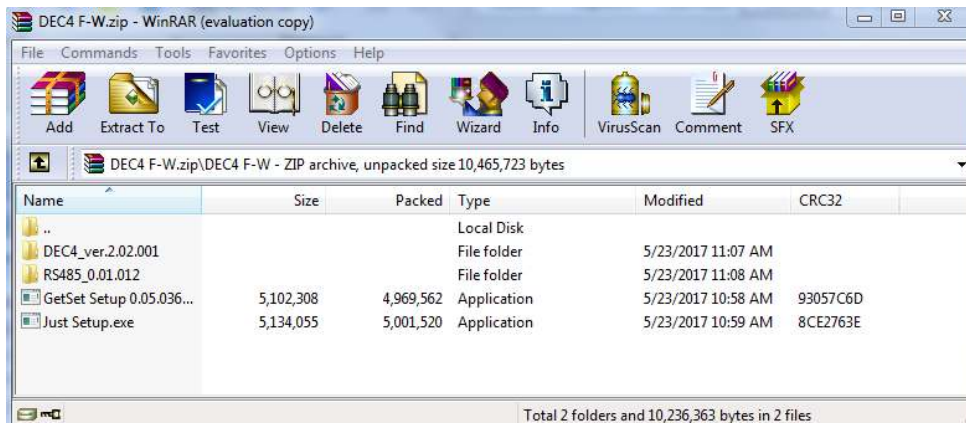

Powered Target DEC4 with 51.485 RS485 communication interface card.

Installation Procedure

1. If not already installed, install a copy of GetSet. *To ensure that the correct USB drivers are loaded, the software should be installed and the PC/Laptop re-started before connection to an RDM-TRI.*

2. If using an Asian character set, go to control panel and select Region and Language. Ensure input locale for non Unicode programs is set to a non Asian language

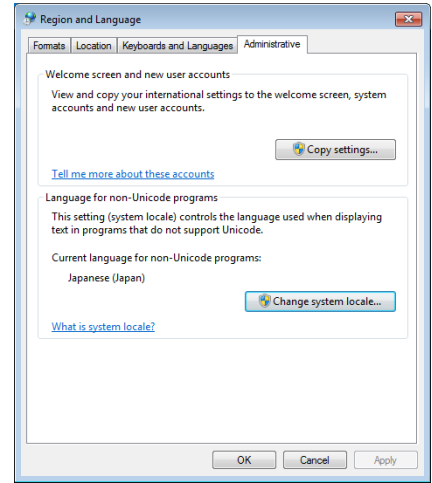

3. Plug your RDM-TRI in to your PC and connect to the RS485 connection on the DEC4 communications board with the fly lead, as shown below.

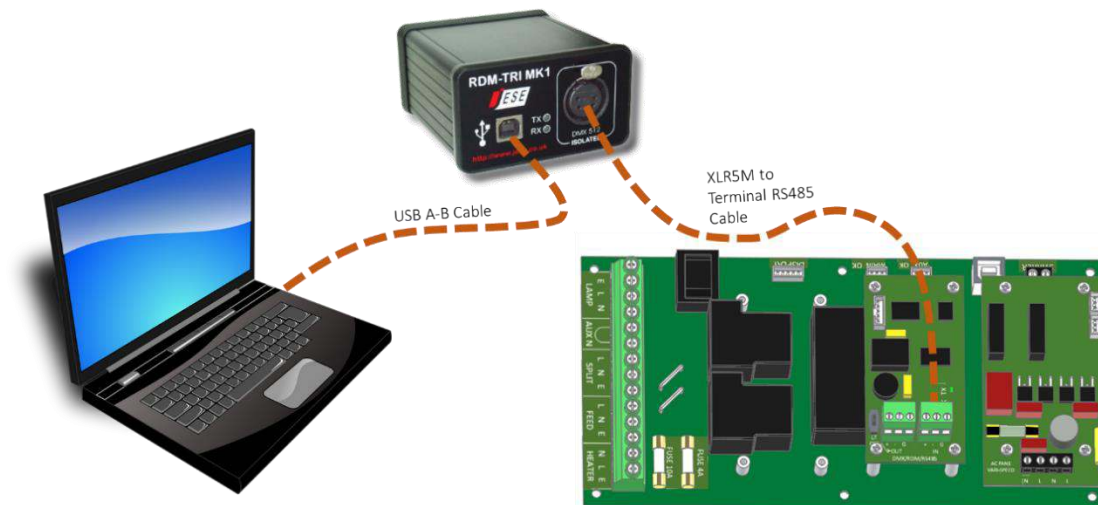

4. Power up the target SCB, ideally with mains power, or alternatively, with a USB power adaptor connected to the USB Port on the SCB.

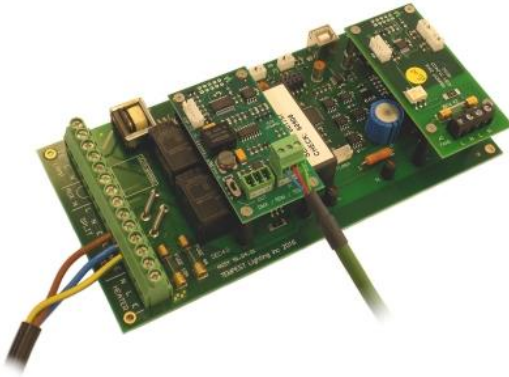

5. On older revisions of DEC Firmware, if the elected DEC 'DATA MODE' is set to 'RS485 TEMP', select 'RDM MONITOR' mode using the DEC user display. On more recent revisions of Firmware, the appropriate mode will be automatically selected.
6. Open the GetSet application, connect to the RDM-TRI and discover the DEC. To run discovery, click the Icon indicated below
7. Right click on the highlighted item in the list view and select 'Reprogram' from the popup menu. This will open the firmware upload tool.

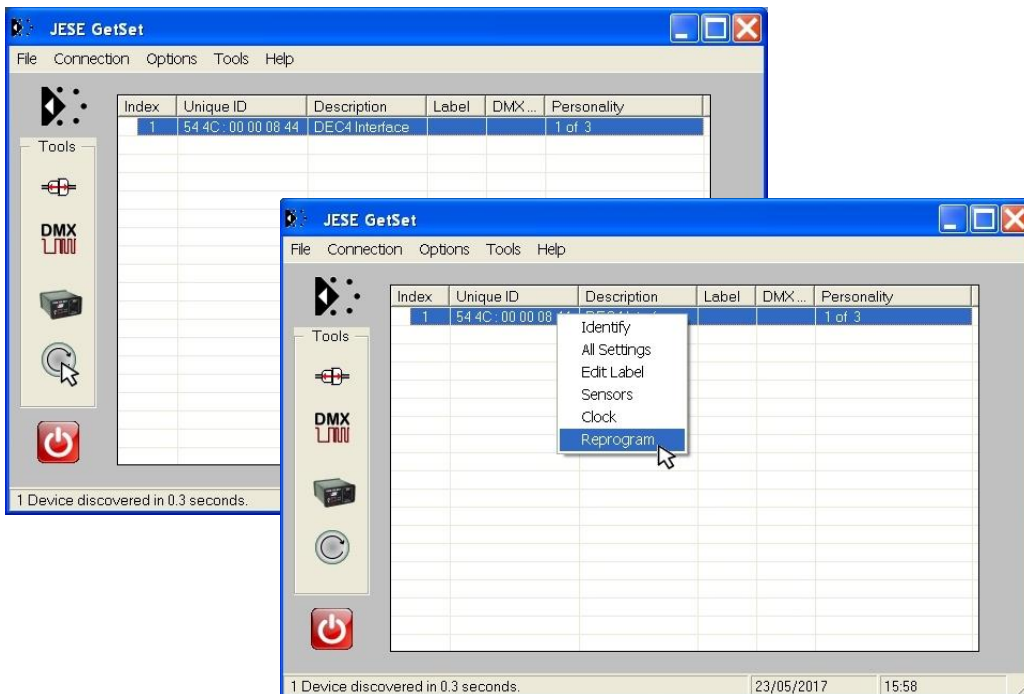

- In the Firmware upload handler, search for a file to upload by clicking the file icon. Find and select the file to load and click the Open button.

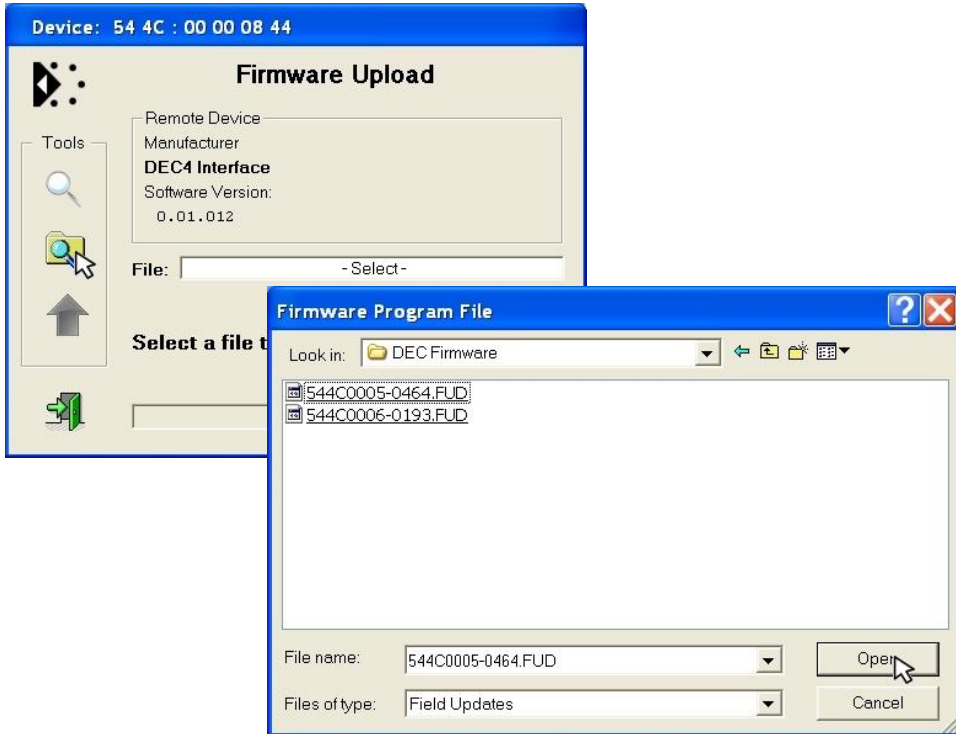

- On returning to the File upload tool window, select the green upload arrow to initiate the upload process. The upload will start.

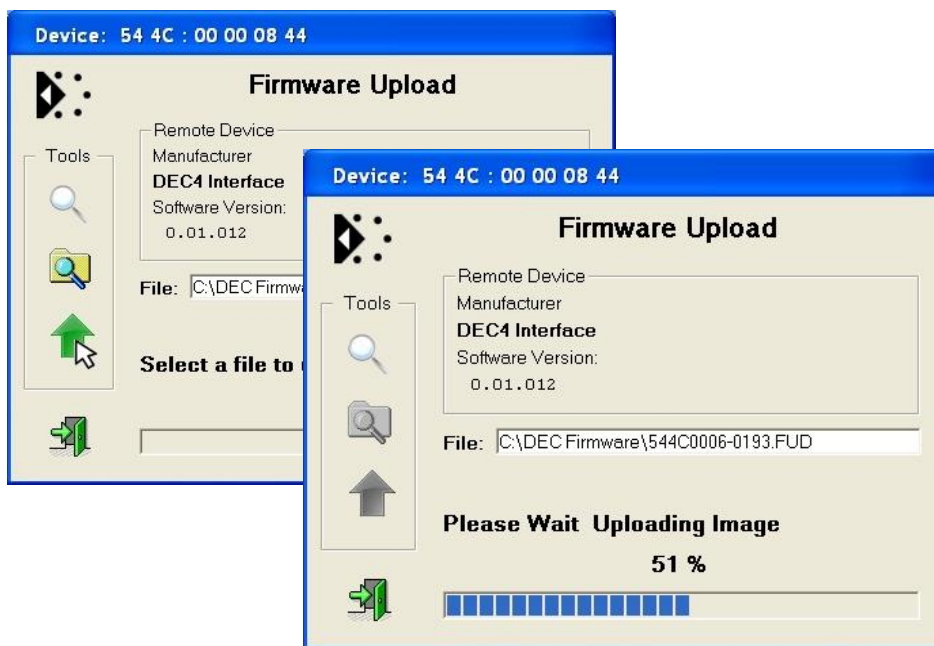

10. On successful completion of upload and restart, the firmware upload is complete.

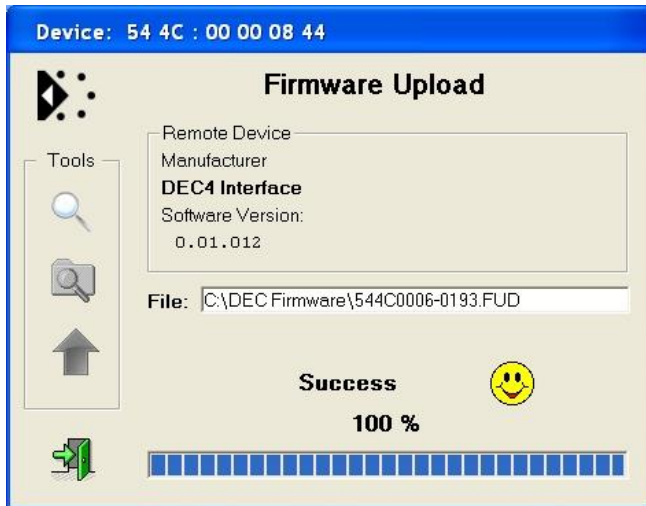

Repeat from stage 8 to 11 for each additional file to upload.

On completion of the upload, dismiss the upload window and return to the main window.

Close the application and disconnect the USB Cable from the SCB

Important:

If the Tempest enclosures are connected to an RDM interface or controller, set the DATA MODE for each enclosure as follows:

- RDM MONITOR ONLY** To view status information over RDM
- RDM + CONTROL** To monitor and over RDM and control the Lamp/Projector relays via DMX

If the enclosures are connected to an Ethernet network for monitoring using TEMP (Tempest Equipment Management Protocol) then the appropriate mode

Routine Maintenance

Check the following every six months:

Clean Port Glass

Clean port glass using a window cleaning fluid or detergent.
Use a soft, lint free cloth.

Check Filter

In most cases the filter will be good for 1-2 years. If the filter becomes clogged the temperature inside the enclosure will start to rise. This is an indication that the filter must be changed.

Part Numbers:

51.HF.11 Blizzard 050, 100 Replacement Filter

51.HF.15 Blizzard 150 Replacement Filter

To replace filter from below

1. Remove the 8 filter clamp screws.
2. The filter will drop out.
3. Replace filter and filter clamp.

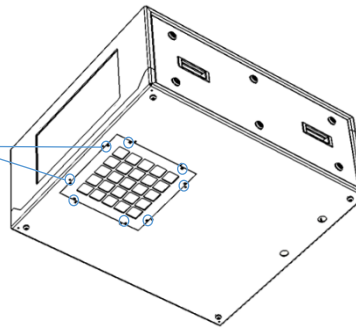

To replace the filter from inside the enclosure

1. Remove both side panels
2. Slide the projector tray out (projector Slide models), OR:
3. Remove the projector (fixed mount models)

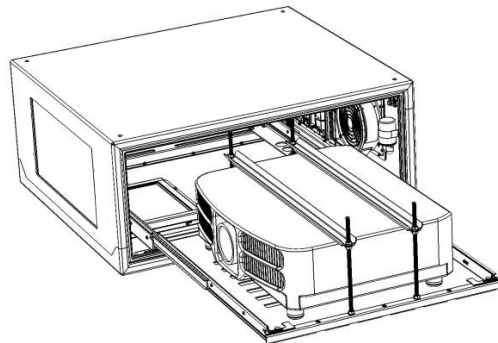

4. Remove the eight M4 nuts holding the filter assembly

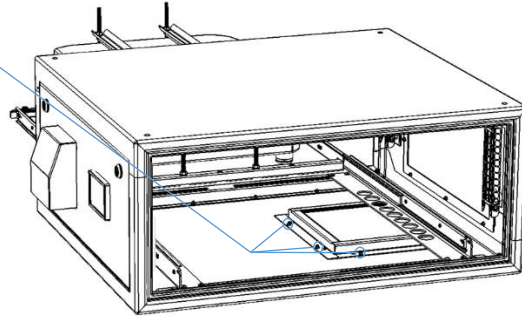

5. Remove the filter clamp screws
6. Replace the filter and filter clamp
7. Replace the filter assembly

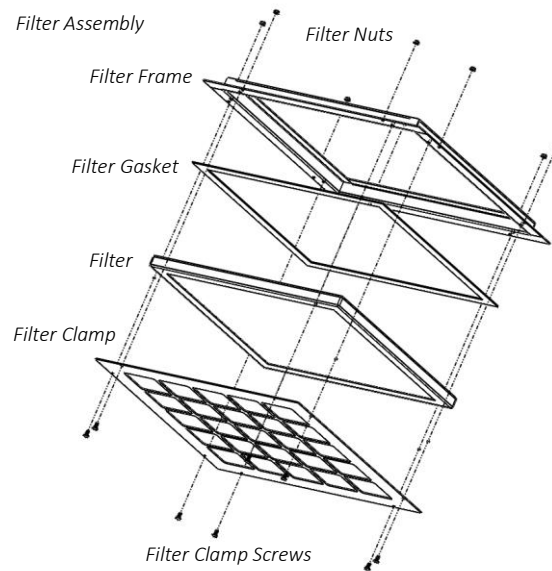

Check Temperature/Humidity Sensor

If the sensor above the port glass is defective, the controller may not operate correctly. A defective sensor will result in one of three messages appearing on the DEC user interface.

If you see any of these messages, contact Tempest for a replacement sensor.

RH: 5%
RH: 100%
RH: ####

For After Sales Support

Contact your Tempest dealer or email info@tempest.biz

Troubleshooting

Projector does not have power:

1. Check Projector power switch
2. Check projector is plugged into DEC4 projector outlet
3. Check that enclosure feed circuit is on
4. Check DEC4 User Interface leds are on. If feed circuit is on and UI leds are off, check feed wiring to DEC terminals and meter DEC4 projector outlet for power
5. If UI lamp led is on and DEC4 projector outlet is live, there is a projector fault.

Enclosure overheats:

1. **Is the projector connected to the DEC4 projector receptacle?** If the projector is powered independently the controller has no way to know when to turn on the exhaust fans!
2. Is the filter clogged or obstructed?
3. Check that the Fan led on the UI is on when the projector is running. If not, then the projector is probably not connected to the DEC (see 1).
4. If the fan led is on, check that the fan is running. If not, check fan wiring. If wiring is ok, fan may be faulty.
5. Check the UI display for RH (relative humidity) message. If display reads RH 5%, RH 100%, or RH####, there is a sensor fault. Contact Tempest for a replacement sensor.

Dirt/Debris inside enclosure

1. Filter is either missing or damaged?
2. Filter is not properly seated
3. Side panels or back door is not firmly latched

Water in enclosure

1. Check the drain holes in the bottom of the enclosure. If they become blocked, and water that gets in cannot escape.
2. Check seals around side panels and back door

Fan LED is on but fans do not operate

The exhaust fan is protected by a 20mm 4A slow-blow fuse on the DEC4 motherboard, and a secondary fuse on the fan board. In very exceptional cases it is possible that either fuse could fail. Check visually.

The fuse is protected with a clear resin sealant and soldered to the circuit board. With care, you can de-solder the fuse and replace it, but we recommend replacing the DEC4 motherboard to maintain the integrity of the board's conformal coating.

Heater LED is on but heater does not operate

The heater is protected by a 20mm 10A slow-blow fuse on the DEC4 motherboard. In very exceptional cases it is possible that it could fail. Check visually.

The fuse is protected with a clear resin sealant and soldered to the circuit board. With care, you can de-solder the fuse and replace it, but we recommend replacing the DEC4 motherboard to maintain the integrity of the board's conformal coating.

None of the above?

Contact info@tempest.biz

Warranty

INSPECTION/WARRANTY/RETURNS.

A. Customer, at its sole expense, shall inspect all Goods promptly upon receipt and accept all Goods that conform to the specifications or catalog. All claims for any alleged defect in or failure of the Goods or Seller's performance to conform to the Contract, capable of discovery upon reasonable inspection, must be set forth in a written rejection notice detailing the alleged non-conformity, and be received by Seller within thirty (30) calendar days of Customer's receipt of the Goods. Failure by Customer to notify Seller of the alleged non-conformity within thirty (30) days will be conclusive proof that the Goods have been received by Customer without defects or damage, and in the quantities specified on the bill of lading and shall constitute an irrevocable acceptance of the Goods and a waiver of any such claim in connection with the Goods.

B. Seller warrants to Customer only that the Goods will be free from defects in material and workmanship at the time of delivery and, subject to the exceptions and conditions set forth below, for the following period (the "Warranty Period"): twelve (12) months from the date of shipment by Seller. Seller may provide additional years of warranty coverage beyond 12 months, at the rate of 2.5% of the net sale price per year, up to a total of four additional years' coverage beyond the standard 12 month warranty period. Seller will remedy a defect as set forth in paragraph 7 D, below, (the "Warranty"). The Warranty is subject to each of the following exceptions and conditions:

1. Customer must promptly (and in all events within the Warranty Period) notify Seller of any alleged defect in a written notice (the "Notice") which shall set forth the quantity, catalog number, finish, original purchase order number, Seller's invoice number on which Goods were originally billed and a statement of the alleged defect, along with digital photographs showing such defects where feasible.

2. The Warranty shall not apply: (i) to any claimed defect that was capable of discovery upon reasonable inspection and deemed to be waived under paragraph A, above; (ii) to any Goods that have been subject to misuse, abnormal service or handling, or altered or modified in design or construction; (iii) to any Goods repaired or serviced by any person other than Seller's authorized service personnel or to Goods installed other than according to installation instructions, or (iv) with respect to normal wear and tear.

3. Seller makes no Warranty with respect to parts or components that are not the product of Seller, and specifically makes no warranty whatsoever for equipment housed inside enclosure products manufactured by Seller.

4. The Warranty is Seller's exclusive warranty with respect to the Goods. Seller makes no warranties, guarantees or representations, express or implied, to Customer except as set forth in this section. ALL OTHER WARRANTIES, EXPRESS OR IMPLIED, INCLUDING, WITHOUT LIMITATION ANY IMPLIED WARRANTY OF MERCHANTABILITY OR OF FITNESS FOR USE OR FOR A PARTICULAR PURPOSE, ARE HEREBY EXCLUDED AND DISCLAIMED.

C. Seller will accept the return of Goods properly rejected under paragraph A, above, or as to which Notice of an alleged breach of Warranty has been timely given and such Goods may be returned to Seller, freight prepaid, but only upon Customer's receipt of Seller's written return material authorization ("RMA") and shipping instructions. The RMA shall be void if the Goods are not received within 45 days after issuance of the RMA. No deduction or credit in respect of any rejected or returned Goods shall be taken until Customer has received Seller's further written deduction or credit/authorization following Seller's inspection to confirm nonconformity or defect. Seller will charge to Customer any and all costs incurred by Seller in connection with the handling, shipping, inspection and disposition of any returned Goods that are determined by Seller not to have been nonconforming upon Delivery or as to which the warranty hereunder is not applicable.

D. UPON ANY PROPER RETURN PURSUANT TO PARAGRAPH C, ABOVE, WHETHER IN CONNECTION WITH A REJECTION OF GOODS OR AN ALLEGED BREACH OF WARRANTY AND BASED UPON THE CONDITIONS SET FORTH IN THIS PARAGRAPH 7, SELLER AGREES THAT IT WILL, AS THE SOLE AND EXCLUSIVE REMEDY UNDER THE CONTRACT OR OTHERWISE, FOR ANY NONCONFORMITY OR BREACH OF WARRANTY, AND AT SELLER'S SOLE ELECTION: (i) REPAIR SUCH GOODS; OR (ii) REPLACE SUCH GOODS.

Appendix – TEMP Protocol

AVAILABLE TO SPECIAL ORDER

Tempest can optionally provide a firmware load that facilitates TEMP over RS485, suitable for interfacing to an Ethernet adapter. TEMP is a lightweight proprietary ASCII based protocol, intended for rapid integration into management systems. With TEMP and a suitable RS485 to Ethernet adaptor connected to the DEC DMX connectors, your DEC may be configured and monitored over an IP network.

Please contact factory for ordering information.

Physical Layer

1. EITHER: Use a 51.EN Ethernet daughter board plugged directly to the DEC4 motherboard, connected to your TCP/IP network.
2. OR: Use a 51.485 RS485 daughter board on each of a number of DEC4 motherboards, and use one of the convertors listed below to bridge to your TCP/IP network.

Suitable Converters include:

<http://gridconnect.com/rs485-ethernet.html>

<http://www.audon.co.uk/lan232/ENET485-POE.html>

<http://uk.rs-online.com/web/generalDisplay.html?id=brainboxes>

Developer's Guide

Download the Developer Guide from www.tempest.biz/tech-support.