

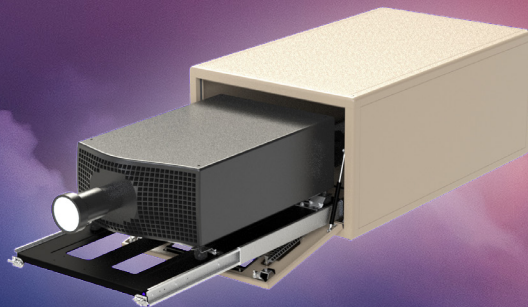

TEMPEST

# Cyclone<sup>G4</sup>

Outdoor  
Projector  
Enclosures  
20-45K



**G4** Fourth  
Generation  
Projector  
Enclosures



# Cyclone

## Outdoor Projector Enclosures

Cyclone is the world's most popular outdoor enclosure for permanent installation of large format video projectors in any climate, for video mapping, outdoor attractions, advertising and outdoor movies.

Cyclone models are tailored specifically for each projector type. Each Cyclone model has been thoroughly tested and approved with its designated projector before being released for production.

Now Cyclone comes with all the new features you've asked us for:

- *Lightweight aluminum welded construction*
- *Powerful AC fan*
- *Salt fog filtering, with positive pressure option*
- *Local TCP/IP or web-based monitoring service*

All Cyclone models feature Tempest's patented Digital Enclosure Control system (DEC4™), now available with optional remote monitoring over your TCP/IP network.

DEC4 will keep your projector warm when it's cold, cool when it's hot, and will never allow deadly condensation to form.

And all Cyclone models feature Tempest's hydrophobic inlet filters, blocking salt and other pollutants from getting near your projector.

All Cyclone models can be ordered in the following configurations, to suit any outdoor projection project.

### Landscape

The standard configuration — the projector may be configured tabletop or ceiling style, with front or rear slide access.

### Portrait

Cyclone portrait enclosures are available to special order for all applicable projectors.

### Ultra-Short-Throw

Cyclone is ready for the UST revolution — now you don't need to own the plot across the street to project on the front of your building! UST models may be configured to project either up or down, for ground or rooflevel installation.

### Cyclovator

Cyclovator allows any Cyclone enclosure to be tilted up to 60 degrees up or down, and restored to horizontal for safe projector service access.

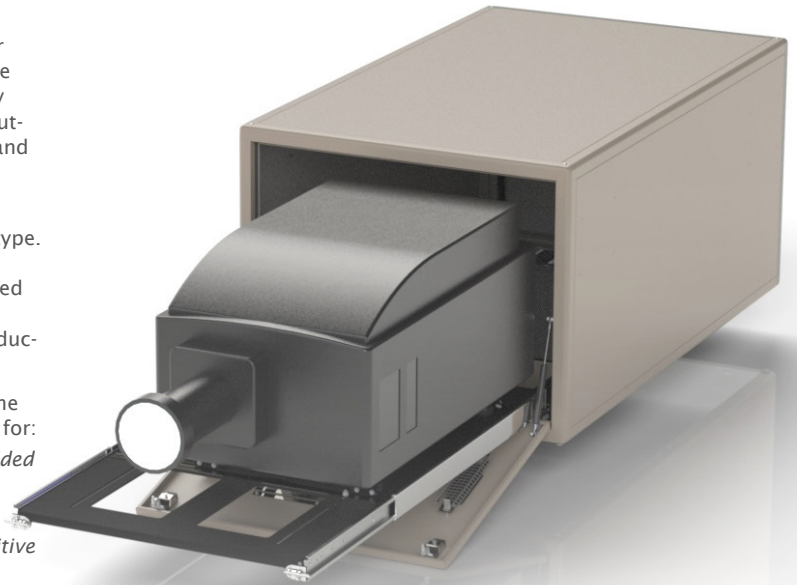

*Cyclone 55.400 for Christie Roadie 45K.*

*Tip: You can specify most Cyclone models to slide front or back*

*Cyclone 55.210P Portrait enclosure for Panasonic PT-DZ21K*

*Tip: Cyclone's Portrait mount allows you to adjust pan and roll with the projector feet, and the mounting plate pivots for  $\pm 7^\circ$  tilt.*

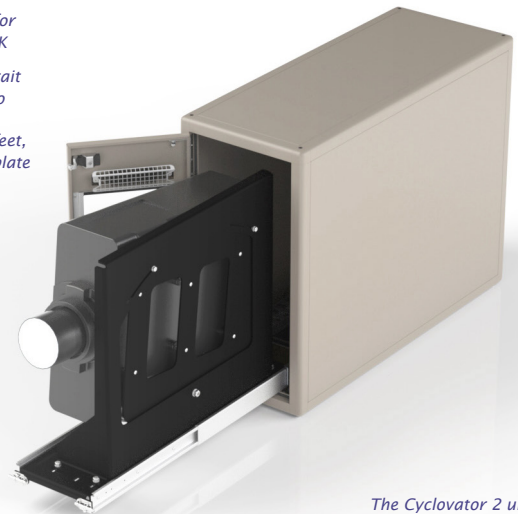

*The Cyclovator 2 under this Cyclone 55.310 can tilt its Boxer projector up to 60° either up or down, with a repeatable stop and a positive lock for accurate show positioning.*

*Tip: Use Cyclovator 2 base-up to hang Cyclones at any angle from a truss or structure*





# Cyclone

Outdoor  
Projector  
Enclosures

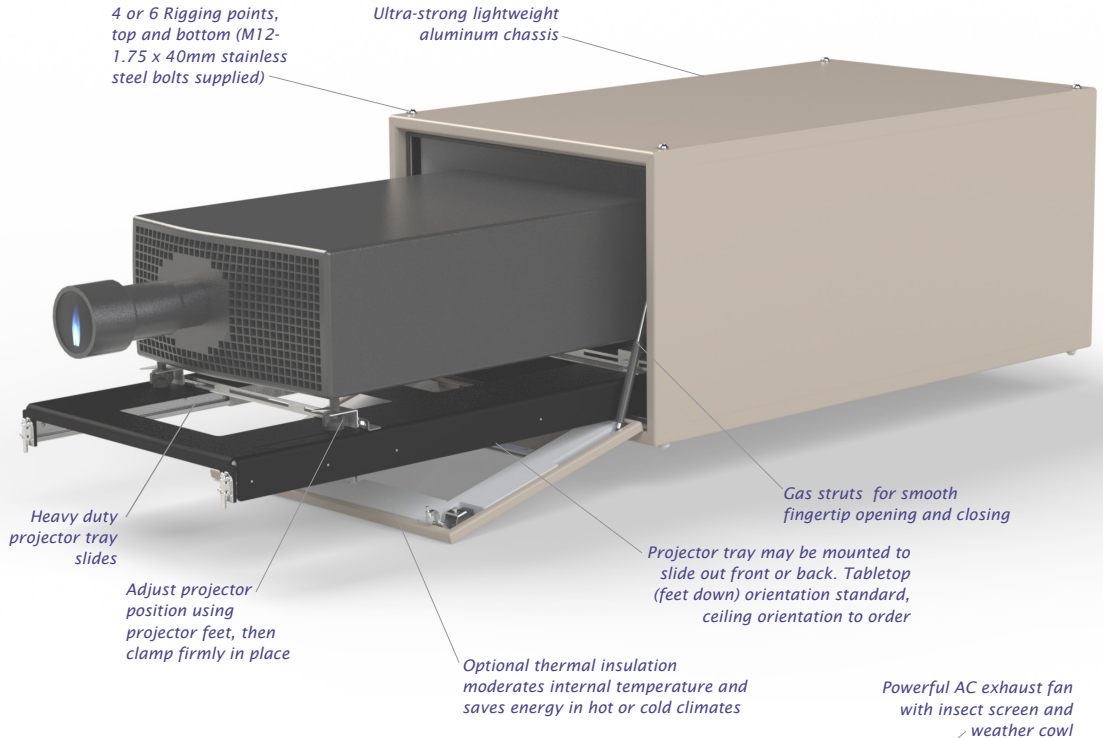

4 or 6 Rigging points, top and bottom (M12-1.75 x 40mm stainless steel bolts supplied)

Ultra-strong lightweight aluminum chassis

Heavy duty projector tray slides

Adjust projector position using projector feet, then clamp firmly in place

Gas struts for smooth fingertip opening and closing

Projector tray may be mounted to slide out front or back. Tabletop (feet down) orientation standard, ceiling orientation to order

Optional thermal insulation moderates internal temperature and saves energy in hot or cold climates

Powerful AC exhaust fan with insect screen and weather cowl

Tempered low-iron optical grade port glass

Lockable latches front and back assure security and a perfect seal

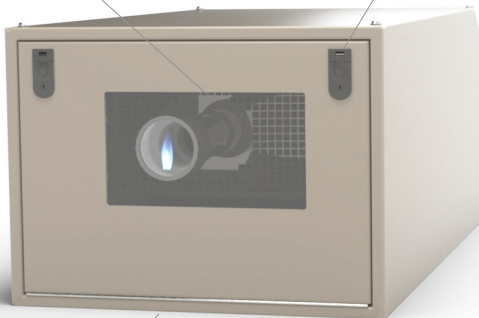

Lockable back door for easy relamping access without moving the projector

DEC4™ User Interface, for customized setup and system monitoring. May be monitored remotely over RS485 (RDM) or Ethernet

Cyclone's hydrophobic HEPA inlet filter (under) keeps out dust, oil and salt fog. Replacement access from below or inside

DEC4 Enclosure Controller with patented Goldlocks™ OS and remote monitoring option

High power AC exhaust fan(s) change the air inside the enclosure every 1-2 seconds.

Note: with the Positive Pressure option, the fan runs continuously at low speed when not required for cooling

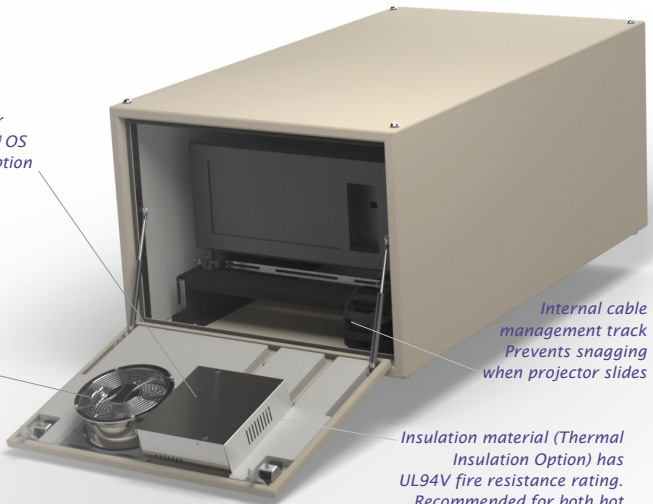

Internal cable management track Prevents snagging when projector slides

Insulation material (Thermal Insulation Option) has UL94V fire resistance rating. Recommended for both hot and cold climates

# Cyclone

Outdoor  
Projector  
Enclosures

## Portrait

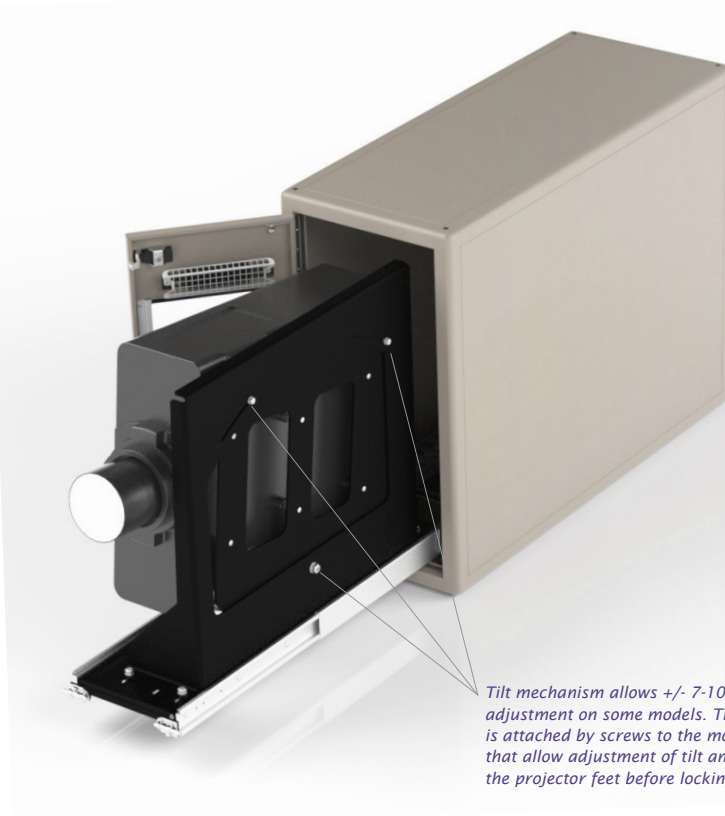

Like all Cyclone models, each Cyclone portrait enclosure is customized for the intended projector, so we need to know the projector you're using when you order.

Not all projectors may be used in portrait mode — check with your projector manufacturer before ordering.

Some projectors may be used in portrait mode but only in one orientation — either base left or base right (picture here shows a Panasonic PT-DZ21K installed base left).

*Tilt mechanism allows +/- 7-10° projector tilt adjustment on some models. The projector is attached by screws to the mounting plate that allow adjustment of tilt and roll using the projector feet before locking down.*

## Ultra Short Throw

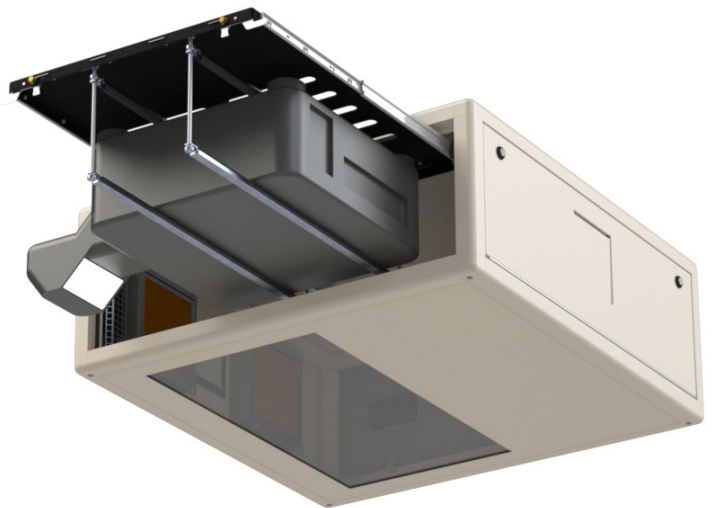

Now that UST lenses are becoming available for large format projectors the creative community is waking up to their amazing potential for mapping, informational signs and advertising. UST outdoor enclosures allow you to paint the outside of your building without having to own the block across the street!

UST enclosures are wider than standard landscape enclosures, to allow for the extreme width

of the projection beam without clipping.

Cyclone UST enclosures may be configured to mount above the image (projecting down) or below it (projecting up).

The lenses may be fixed but the projector mount allows consid-

erable adjustment of pan, tilt and roll.

For the present, these UST enclosures are specially built for your project: Contact the factory and talk to us about your next UST adventure!



# Cyclone Outdoor Projector Enclosures

All Cyclones come with four M12 threaded sockets — one at each corner — top and bottom. Larger models have additional threaded sockets midway along their length for additional security.

Stainless steel bolts are provided for attachment to any suitable support structure.

Tempest recommends only the use of stainless steel hardware for installing enclosures outdoors.

Three additional rigging options are available for any Cyclone enclosure:

## Unistrut Kit

Easy attachment to any structure using these two Unistrut rails. Simply use spring nuts supplied to bolt to your structure, without worrying about precise hole locations.

Unistruts may be mounted top (shown here) or bottom.

*Two Cyclone 55.240 for Christie Roadster, with 51.SK Stacking Kit. The stacking kit gives the enclosures the required 3" [75] airgap, and assembles easily with clevis pins*



*Cyclone 55.310 with 51.C2 Cyclovator.*

*NOTE: Cyclovator requires 51.UR.xxx Unistrut Rail Kit*

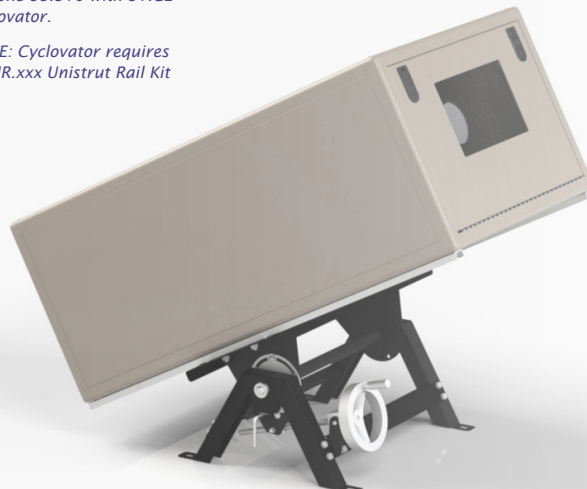

## Rigging Options



*Cyclone 55.240 for Christie Roadster, with 55.UR.240 Unistrut Kit. Unistrut rails may be mounted top or bottom.*

## Stacking Kit

Stack two or more Cyclone enclosures of the same type using this stacking kit.

Male and female parts attach to the threaded corner holes, and are simply joined together using a stainless steel clevis pin.

*See also the swivel stacking kit on the next page.*

## Cyclovator 2

Our fabled Cyclovator has a new look for G4! Now tucked snugly under the center of gravity of the enclosure the new Cyclovator requires less effort to raise and lower, and is also far more stable in crosswinds.

Use Cyclovator on the ground to cover tall buildings, or on a rooftop to project to ground level. Either way, Cyclovator allows you to project up to about 60° off horizontal, and then bring the projector safely back to horizontal for service and lamp changes.

You can even bolt this Cyclovator to a truss or other structure and use it to hang any Cyclone enclosure at any angle.

In every case, Cyclovator has a positive index ring that you set to come back to your show position with absolute repeatability, time after time...

# Cyclone Outdoor Projector Enclosures

## Sun Shade

This reflective aluminum panel mounts easily on the top of any Cyclone enclosure to provide extra daytime protection in hot, sunny climates. The cover not only deflects sunlight, but also provides a 75mm air gap between the shade and the enclosure top, promoting convective air movement. Use in conjunction with 55.TI thermal insulation in sunny areas with daytime temperatures frequently above 40°C (104°F).

*See also Thermal Insulation Kit, next page.*

## Rigging Options

*55.SH.xxx Sun Shade attaches easily to the Cyclone's top rigging points. Note that the xxx matches the enclosure part number, eg 55.SH.310 for Cyclone 55.310 shown here.*



## Swivel Stacking Kit

Stack two Cyclone enclosures (must be the same model), and angle them up to 60 degrees apart — great for short -throw edge blending jobs.

Stainless steel stacking kits attach to M12 rigging points, and locking bolts are provided to secure pan angle when aligned.

Swivel Stacking kit part number must match Cyclone enclosure — eg 55.SS.310 is the Swivel Stacking kit for two Cyclone 55.310 enclosures as shown here.



# Cyclone

## Outdoor Projector Enclosures

### Individual Fan Monitoring

G4 Cyclone enclosures can also tell you how each fan in a whole installation is performing. DEC4 compares calculated and actual fan speed, and is able to alert you if one of the fans in a system needs attention.

Combined with Tempest's upcoming remote monitoring service this means you could be receiving an alert on your smartphone one day telling you it's time to check fan two on enclosure three!

### Climate and Filter Protection

#### 55.TI Thermal Insulation Kit

Cyclone enclosures may be used safely in climates with temperatures ranging from 0-40°C. In hot climates where the enclosures may be exposed to direct sun during the day, and in cold areas where the temperature may drop below freezing, we offer a factory installed insulation kit. With the TI kit Cyclone may be used in temperatures down to -20°C, and it will also thrive in desert sun with daytime temperatures above 50°C.

*See also Sun Shade on previous page.*

#### 55.IC.xx Inlet Cowl

Use this cowl to keep rain out of the inlet filter if the Cyclone enclosure is angled more than 45° up or down.

#### 55.DFB.xx Desert Filter Baffle

In desert areas severe windblown sand may damage Cyclone's inlet filter, allowing sand and dust ingress in sandstorm conditions. The desert baffle slows down these particles, preventing filter abrasion.

### Positive Pressure and Salt Air

We do a lot of cruise ship jobs, as well as beach resorts and attractions where salt air can be a real problem. Now all Tempest G4 outdoor enclosures can be supplied with a Constant Positive Pressure setting that runs the enclosure fan(s) all the time at low power, maintaining just enough positive pressure to prevent salt or other pollutants sneaking in the back door when the projector is not running.

Specify option 55.PP.

### System Monitoring

#### 51.485 RS485 Comms Board

Daisy-chain a group of Cyclone enclosures together with this RS485 board — one per enclosure.

#### 51.EN Ethernet Comms Bridge

Use this RS485/Ethernet adapter to connect one Cyclone or a group of Cyclones connected using RS485 to a PC or Tempest System Manager

#### 51.TSM System Manager

The Tempest System Manager (coming soon) monitors any Tempest G4 system, with any number of enclosures. System manager may be connected to a PC for local monitoring, and/or to the internet, for remote monitoring.

## G4 Fan Control

## More Options

### 51.RMS Remote Monitoring Service

We do the work for you! We monitor your installation 24/7 and send you email alerts if we spot anything out of the ordinary. Requires Tempest System Manager — coming soon.

*See below for more information on DEC4 operation, Goldilocks™ OS and system monitoring.*

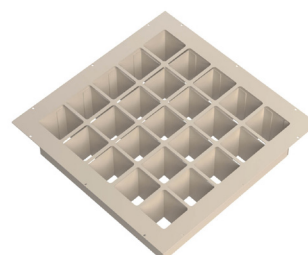

*Desert Filter Baffle*

# Cyclone

## Outdoor Projector Enclosures

### Goldilocks™

How do we keep projectors from roasting when it's 50°C and there's no shade?

And prevent condensation from destroying your projector overnight?

Tempest's unique Goldilocks™ Operating System (patents pending) brings enclosure control to a new level.

Goldilocks keeps the air temperature inside your enclosure just right, removing heat from the projector when the lamp is on or when the enclosure is heated by the sun. We're changing the air about every second.

Goldilocks uses a heater to maintain a minimum temperature in cold climates.

And Goldilocks tracks temperature and humidity 24/7, keeping relative humidity inside your enclosure just right by using heaters to raise the air temper-

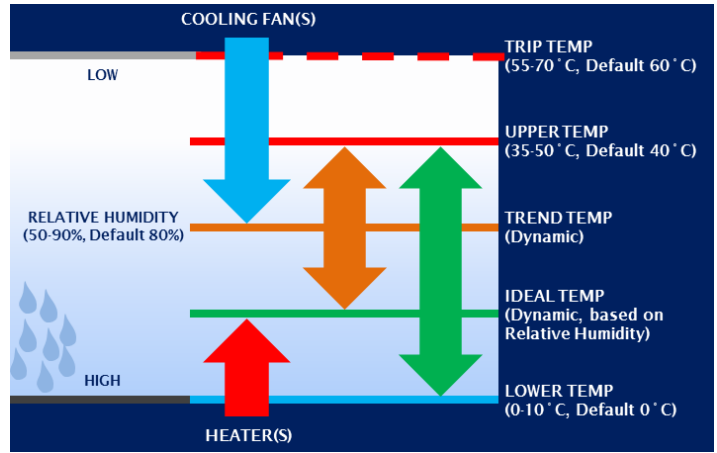

ature when needed, adapting constantly to prevent deadly condensation.

New to these Fourth Generation enclosures, Goldilocks features a homogenizing blower that stirs the air periodically inside the enclosure when the projector is not in use, preventing hot and cold spots and further reducing condensation risk.

### Data Logging

Also new with G4, Goldilocks logs all system events for a week, providing invaluable insights in the event of a field service issue. Data logs will be recorded longer term in the G4 System Manager (see below) and will be available locally via USB or remotely over a network or the internet.

### Remote Monitoring

It's important to understand that most Cyclone installations are running on factory default settings and are not connected to any kind of network. In many cases that's just fine, but in larger systems or mission-critical applications a remote monitoring system is a lifesaver.

Cyclone reports everything it knows on the user interface display on the back door. Now you can get the same information remotely, in several different ways:

#### TCP/IP Direct

Plug in an Ethernet board to your Cyclone, and now you can find out what's going on in the enclosure. Temperature, humidity, line voltage, current, projector, fan and heater status are just some of the data you can monitor using this feature.

Use Tempest's prepackaged front end, write your own, or integrate with many popular projector control protocols.

#### RS485 to TCP/IP

For larger systems we offer a simple RS485 plug-in board so you can daisy-chain between groups of enclosures, bridging to Ethernet at one or more enclosure locations. Either way,

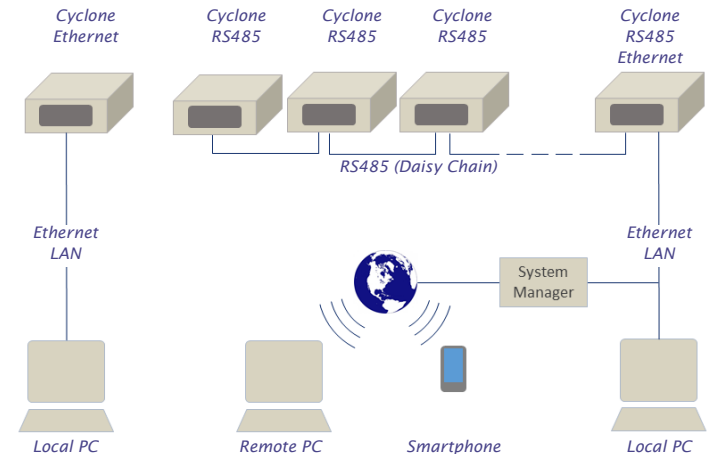

you get all the information we know about back in the control room.

#### Web-based Monitoring

With the addition of a Tempest G4 System Manager (coming soon), the system now serves up a web page that can be monitored anywhere.

With the G4 System Manager, Tempest will offer a real-time system monitoring service, alerting you by email if anything happens to your system.

#### And on your Smartphone!

Not cool enough for you? System Monitor will also feature a smartphone app, so you can stay connected to your Tempest enclosures anytime, anywhere.

For more on  
DEC4, Goldilocks  
and remote  
monitoring,  
download the  
Cyclone User  
Manual from  
[www.tempest.biz](http://www.tempest.biz)



# Cyclone G4 Ordering Guide

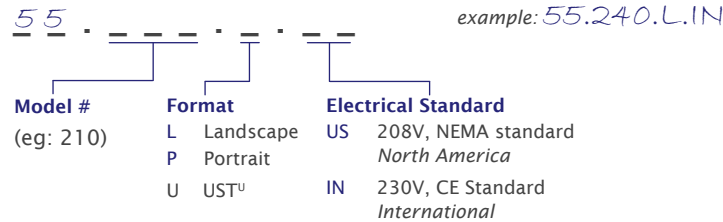

Model	Description	Dimensions (lwh)	Weight	Projector Type <sup>1</sup>	Shipping Dimensions (lwh)/Weight
55.210.L	Cyclone 210.L	51x32x22in 130x81x56cm	145lb/66kg	Panasonic PT-DZ21K, PT-RZ12K, PT-RZ21K, Barco F90-W13, DPI Highlite 4K, Titan Quad	70x38x32in/178x97x81cm 253lb/115kg
55.210.P	Cyclone 210.P	51x25x34in 130x64x86cm	175lb/80kg		70x33x50in/178x84x127cm 305lb/139kg
55.240.L	Cyclone 220.L	53x34x26in 135x86x66cm	190lb/86kg	Christie Roadster, (suffix.R)	70x38x32in/178x97x81cm 330lb/150kg
55.240.P	Cyclone 240.P	53x25x34in 135x64x86cm	182lb/83kg	BARCO HDX, (suffix H)	70x33x50in/178x84x127cm 374lb/170kg
55.250.L	Cyclone 250.L	51x38x24in 130x97x61cm	188lb/86kg	Epson Pro L25000U	70x38x32in/178x97x81cm 327lb/149kg
55.250.P	Cyclone 250.P	51x25x41in 130x64x104cm	212lb/96kg		70x33x50in/178x84x127cm 368lb/167kg
55.310.L	Cyclone 310.L	59x34x25in 150x86x64cm	203lb/92kg	Christie Boxer, Christie Crimson, Barco UDX, DPI Insight 4K	70x38x32in/178x97x81cm 353lb/161kg
55.310.P	Cyclone 310.P	59x26x36in 150x66x91cm	224lb/102kg		70x33x50in/178x84x127cm 389lb/177kg
55.320.L	Cyclone 320.L	62x38x30in 157x96x76cm	247lb/112kg	Panasonic PT-RZ31K/RQ32K Barco FLM/HDF, DPI Insight Dual	70x44x32in/178x112x81cm 430lb/196kg
55.320.P	Cyclone 320.P	62x28x38in 157x71x96cm	260lb/118kg		70x33x50in/178x84x127cm 389lb/177kg
55.324.L <sup>4</sup>	Cyclone 324.L	62x38x34in 157x96x86cm	247lb/112kg	Christie CP4325, D4K40	70x38x32in/178x97x81cm 430lb/196kg
55.324.P <sup>4</sup>	Cyclone 324.P	62x31x40in 157x79x102cm	260lb/118kg		70x33x50in/178x84x127cm 389lb/177kg
55.400 <sup>d</sup>	Cyclone G4 400	71x42x33in 180x107x84cm	260lb/118kg	Christie Roadie 45K	76x48x43in/193x122x109cm 528lb/240kg
55.450 <sup>d</sup>	Cyclone G4 450	71x38x38in 180x97x97cm	280lb/127kg	Christie D4K35, CP2220/30	76x48x43in/193x122x109cm 539lb/245kg
55.45B <sup>d</sup>	Ballast Encl. <sup>2</sup>	31x24x26in 79x61x66cm	65lb/30kg	Christie Ballast	37x30x32in/94x76x81cm 143lb/65kg
55.500 <sup>d</sup>	Cyclone G4 500	71x38x38in 180x97x97cm	280lb/127kg	BARCO HDQ <sup>3</sup>	76x48x43in/193x122x109cm 528lb/240kg

<sup>1</sup> For projectors not shown here, please contact factory — we will be happy to accommodate any projector type  
<sup>2</sup> Ballast Enclosure for certain Christie 30-45K projectors includes 6'2m DC pigtails, so DC cables are not required  
<sup>3</sup> Barco HDQ — rigging Frame and Air Diffuser are not used in the Cyclone enclosure.  
<sup>4</sup> 55.324 is the same as 55.320, except for Christie CP4325 Dual Power Connectors  
<sup>d</sup> Consult factory for current dimensions and portrait availability  
<sup>u</sup> All UST versions are custom or semi-custom. Please consult factory for details  
 All Cyclone products are built to order. Please consult factory for lead times.  
 All sales are subject to Tempest Lighting, Inc. Standard Terms and Conditions of Sale, available for download at [www.tempest.biz](http://www.tempest.biz).  
 All Schedule B Export Code: 9405.99.0000

## Custom Colors

All the enclosures in this brochure are shown in our popular standard light bronze finish.

White, Black or any RAL color are available to special order.

## Available Options

- |                  |   |                 |   |
|------------------|---|-----------------|---|
| <b>55.UR.xxx</b> | Unistrut Rail Kit (Use the 3-digit enclosure model #, eg 55.UR.200) | <b>51.EN</b>    | Ethernet Bridge   |
| <b>51.SK</b>     | Stacking Kit  | <b>51.TSM</b>   | Tempest G4 System Manager (coming soon)                               |
| <b>51.SS.xxx</b> | Swivel Stacking Kit (xxx = Cyclone model #)                         | <b>51.HF.11</b> | Spare Inlet Filter Cyclone Portrait 55.320 (2 per enclosure)          |
| <b>55.C2</b>     | Cyclovator 2 (requires 55.UR.xxx)                                   | <b>51.HF.15</b> | Spare Inlet Filter Cyclone Landscape 55.2-3xx, Portrait 55.324 and up |
| <b>55.TI</b>     | Thermal Insulation Kit (factory fitted)                             | <b>51.HF.22</b> | Spare Inlet Filter Cyclone 55.400 and up                              |
| <b>51.SH.xxx</b> | Sun Shade (xxx = Cyclone model #)                                   | <b>51.HF.23</b> | Spare Inlet Filter Cyclone Portrait 55.2-310                          |
| <b>55.IC.15</b>  | Cyclone Inlet Cowl for Cyclone 55.2-3xx                             | <b>55.PP</b>    | Positive Pressure Option  |
| <b>55.IC.22</b>  | Cyclone Inlet Cowl for Cyclone 55.400 and up                        | <b>55.AC</b>    | Tempest AC Assist — consult Factory                                   |
| <b>55.DFB.15</b> | Cyclone Desert Baffle for Cyclone 55.2-3xx                          |                 |   |
| <b>55.DFB.22</b> | Cyclone Desert Baffle for Cyclone 55.400 and up                     |                 |   |

For custom options please consult factory

CAD drawings and user manuals at [www.tempest.biz](http://www.tempest.biz)

# Cyclone Configurator

Please complete this form and email to us at [info@tempest.biz](mailto:info@tempest.biz)

Name	
Company	
Email	
Phone	
Project Name & Location	
Projector type	
Cyclone Model	55. _____
Quantity	
Destination Country	
Install Date	
Type	Landscape <input type="checkbox"/> Portrait <input type="checkbox"/> Ultra Short Throw <input type="checkbox"/>
Projector Slide	Front <input type="checkbox"/> Back <input type="checkbox"/>
Projector Mount	Feet Down <input type="checkbox"/> Feet Up <input type="checkbox"/>
<b>Required Options</b>	
Thermal Insulation	Yes <input type="checkbox"/> No <input type="checkbox"/>
Inlet Cowl	Yes, Qty _____ No <input type="checkbox"/>
Desert Filter Baffle	Yes, Qty _____ No <input type="checkbox"/>
Positive Pressure	Yes, Qty _____ No <input type="checkbox"/>
Sun Shade	Yes, Qty _____ No <input type="checkbox"/>
ActiveCool	Yes, Qty _____ No <input type="checkbox"/>
Cyclovator	Yes, Qty _____ No <input type="checkbox"/>
Stacking Kit	Yes, Qty _____ No <input type="checkbox"/>
Swivel Stacking Kit	Yes, Qty _____ No <input type="checkbox"/>
Unistrut Kit	Yes, Qty _____ No <input type="checkbox"/>
Ethernet Comms	Yes, Qty _____ No <input type="checkbox"/>
Spare Inlet Filter	Yes, Qty _____ No <input type="checkbox"/>

Color	Standard, Light Bronze <input type="checkbox"/>
	Custom, RAL # _____
	Gloss Level _____%

Custom Requests:

Factory Use Only:	
SO Number	
Date	

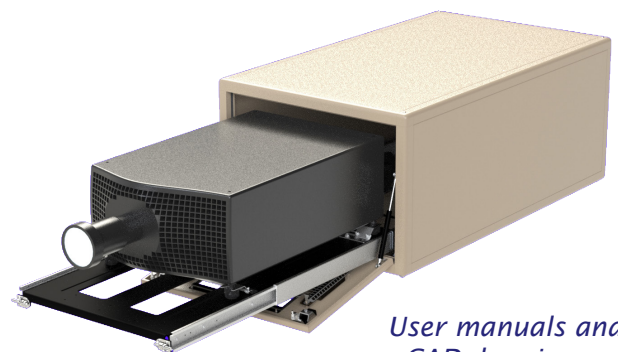

User manuals and  
CAD drawings at  
[www.tempest.biz](http://www.tempest.biz)