



User Manual

Tornado G4

Tornado Marine G4

Revision 01.7

July 2019

© Tempest Lighting, Inc.



Table of Contents

Table of Contents.....	2
Approvals – Europe	5
Approvals – China	6
Introduction	7
IMPORTANT: Safety Advisories	7
Installation.....	8
Dimensions, Rigging Points, and Maximum Luminaire Dimensions/Power	8
Airflow Clearance	10
Snow Clearance	10
Mounting Hardware Options	11
Mounting Bolts	11
Globe Down Tornado Enclosures	11
Horizontal Tornado Enclosures.....	11
Drainage	12
Wiring the Enclosure	13
Power Wiring	13
SAFETY NOTICE	13
Electrical Standards	13
Local Isolator Switch.....	13
Wiring Access – Globe-up Models.....	14
Wiring Access – Globe-down and Horizontal Models	14
One or Two Power Circuits?	16
Single Feed Power Termination.....	17
Split Feed Power Termination	17
AC Supply Voltage.....	17
Wiring – North America/Japan 200-208VAC	18
Wiring – International 220-250VAC	19
Remote Monitoring Connections	20
Direct Ethernet Monitoring Network	20
Line Termination Switch Settings	21
DEC4 Ethernet Adapter – 51.EN	22
Default Configuration.....	22
Additional Support	22
Tempest Equipment Management Protocol	23
DMX/RDM Monitoring Network.....	24
RS485 (DMX/RDM) Cable Terminations.....	25

Luminaire Power Control using DMX512	25
Digital Enclosure Control	26
Schematic.....	26
DEC4 Main Functions	27
Factory Settings – Basic Mode	27
Other Operating Modes	28
Monitor Mode	28
Control Mode.....	28
Service Mode	28
DEC4 Control Parameters	29
Control Interface	30
User Interface LCD Display.....	31
Control Interface Operation	31
Control Menu.....	32
Set DMX Options	32
Set Temp Units	33
Set Temp Ranges	33
Set Lamp On Point.....	33
Reset Lamp Hours.....	33
Status Display.....	34
Safe Mode	35
Safe Mode – What to do:.....	35
Mounting the Luminaire.....	37
Luminaire Base Handles	37
Mounting Bars	38
Mounting The Luminaire.....	39
Omega Clamps.....	40
Screws	41
Quarter-Turn Fasteners (QTF)	42
Install Luminaire in the Tornado Base	43
Vari-Lite Truss Adapters	44
Connect Luminaire Power.....	45
Routine Maintenance	46
Cleaning the Acrylic Globe	46
Cleaning Painted Parts	46
Use of Power Washers	47
Check Inlet Filter.....	47
Exhaust Filters.....	48
Check DEC Control Function	49



Check Temperature/Humidity Sensor	49
For After Sales Support	49
Troubleshooting.....	50
Warranty	52
Appendix – TEMP Protocol.....	53
Physical Layer.....	53
Developer’s Guide	53

Approvals – Europe



CERTIFICATE AND DECLARATION OF CONFORMITY
FOR CE MARKING

Tempest Lighting, Inc.

11845 Wicks Street, Sun Valley, CA 91352, USA

t: +1 818 787 8984 f: +1 818 252 7101 e: info@tempest.biz

www.tempest.biz

Tempest Lighting, Inc. declares that their

Tornado G4 Luminaire Enclosure Series 55.xxx.xx

complies with the Essential Requirements of the following EU Directives:

Low Voltage Directive 2006/95/EC

Test Report G4.51.LVD

Electromagnetic Compatibility Directive 2004/108/EC

Test Report G4.51.EMC

and further conforms with the following EU Harmonized Standards:

EN 60065 : 2002

Test Report 60065.G4.51.01

EN 60529:2001-2002

Test Report 60529.G4.51.02

EN 61000-6-3:2007+A1:2011

Test Report 61000.G4.51.03

EN61000-6-1:2007

Test Report 61000.G4.51.03

EN55015:2006+A2:2009

Test Report 61000.G4.51.03

Dated: 1st July 2016

Position of signatory: President

Name of Signatory: Tim Burnham

Signed below:

on behalf of Tempest Lighting, Inc.



.....

Approvals – China



强制性认证目录外产品确认书
Confirmation Letter for Products
Outside the Scope of China Compulsory Certificate

Ref. No: CL-TEMPEST-160818-1

申请人: Applicant: Tempest Lighting Inc.		地址: Address: 11845 Wicks St., Los Angeles, CA 91352 United States	
生产厂名称: Factory: Tempest Lighting, Inc.		地址: Address: 11845 Wicks St., Los Angeles, CA 91352, USA	
产品名称: Product Name: 投影仪外壳, 灯具外壳 Projector Enclosures Moving Light Enclosures Lighting Enclosures	型号: Model: 18xx.IN, 19xx.IN, 2xxx.IN, 66xx.IN, 52.xxx.IN, 53.xxx.IN, 54.xxx.IN, 55.xxx.IN, 56.xxx.IN	商标: Trademark: Tornado, Twister, Thunder, Blizzard, Whispr, Typhoon, Cyclone, Tacit	
产品标准: Standard: /		HS code: 9405.99.0000	
产品描述(包括使用场所) Product Description (utilization of product) : Enclosures for high-powered luminaires and video projectors for outdoor use and indoor noise attenuation. For professional use only. 产品为用于户外和室内噪声衰减大功率灯具和视频投影仪的外壳。仅供专业使用。			
确认意见 Conclusion: According to the product description, the models above are out of CCC scope 基于产品描述, 如上型号的产品在中国强制性产品目录之外。 本确认书的有效有效期至: August 18th, 2017 Validity Period			



Introduction

Thank you for purchasing a Tempest enclosure! We have worked hard to provide you with the very best product available for its purpose, and we shall continue to do everything possible to ensure that it works well for you for many years to come.

Please read this manual before starting work!

In the event of difficulty, please contact your Tempest reseller or Tempest direct:

info@tempest.biz

+1 818 787 8984

We will do everything we can to help you get the very best results from your Tempest enclosure.

IMPORTANT: Safety Advisories

- All installation and rigging work done must where applicable be designed and built in accordance with norms and standards of the local authority having jurisdiction of the installation site. It is the responsibility of the installer to obtain such approvals as may be required to achieve full compliance.
- All electrical work must be carried out by a suitably licensed electrical contractor in full compliance with local electrical standards.
- Lifting: some enclosures and the equipment inside them may be heavy. Use properly rated lifting equipment where appropriate and never attempt to carry out work with fewer than the number of workers needed to lift safely.
- It is the responsibility of the installer to ensure that all local building, safety and electrical codes are strictly adhered to in the installation of this enclosure. Tempest Lighting, Inc., its employees and agents are in no way responsible for damage arising from failure to follow either the instructions in this manual or building, safety and electrical codes prevailing at the installation location.
- Do not attempt to install or operate the enclosure before fully reading and understanding this manual
- Never allow anyone who has not read this manual to open the enclosure or perform maintenance on the luminaire within.
- Never leave the enclosure unattended when open.
- Always make sure all bolts and latches are tight and safety locks are in place after performing any form of maintenance on the unit.
- Do not open any electrical boxes until power has been shut off to all supply lines to the enclosure (including the one powering the luminaire).
- Do not open the enclosure in wet weather.

Installation

Dimensions, Rigging Points, and Maximum Luminaire Dimensions/Power

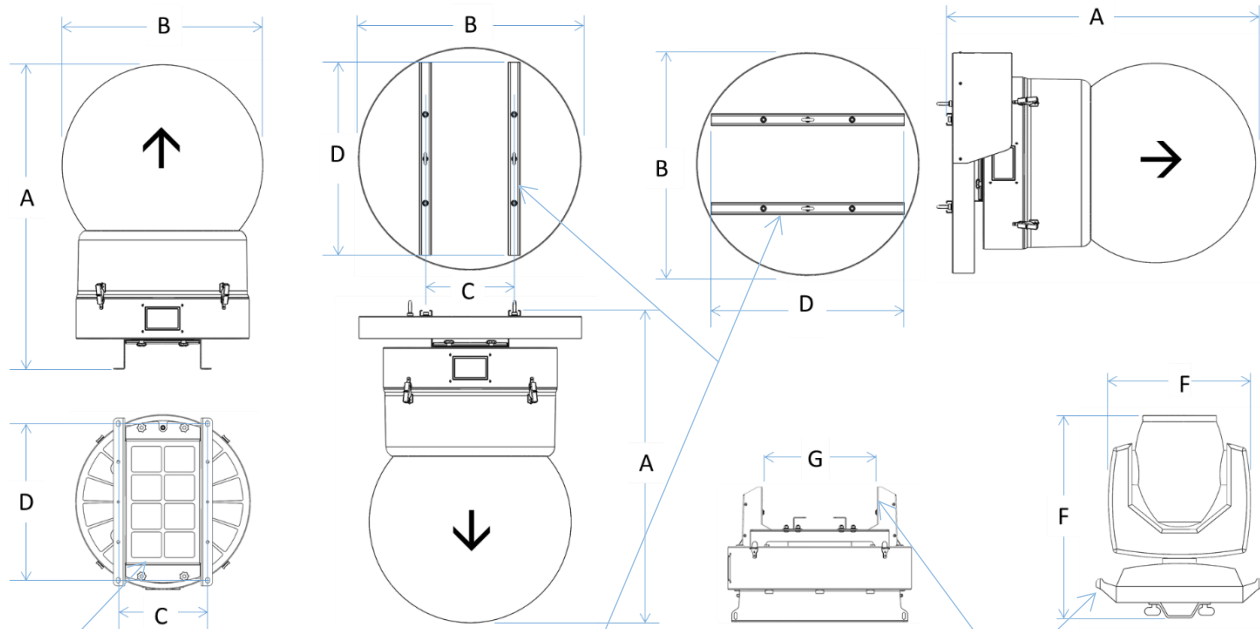

Rigging Points – Globe Up:
Use M12 stainless steel bolts (supplied with shipping pallet) to attach to structure

Rigging Points – Globe Down/Horizontal:
Use M12 stainless steel bolts and Spring Nuts (supplied with shipping pallet) to attach Unistrut rails to structure

Base Width (G): It may be necessary to remove base handles for some luminaires.

Model #	Description	↑ ↓ →	A Height	B Diameter	C Mounting Centers	D Mounting Centers	Weight Lbs/kg	E Luminaire Max Height	F Luminaire Max Width	G Luminaire Base Width	Luminaire Max Watts
1850.xxG	Tornado 1850	↑	32"/813	23"/584	11.95"/304	21"/533	42/19	16.5"/420	16"/410	14.5"/370	500W
1850.xxGV	Tornado 1850	↓	33"/838	30"/762	11.95"/304	23"/584*	45/21	16.5"/420	16"/410	14.5"/370	500W
1850.xxGH	Tornado 1850	→	33"/838	30"/762	11.95"/304	23"/584*	46/21	16.5"/420	16"/410	14.5"/370	500W
1850.xxM	Tornado Marine 1850	↑	33"/838	23"/584	11.95"/304	21"/533	42/19	16.5"/420	16"/410	14.5"/370	500W
1850.xxMV	Tornado Marine 1850	↓	34"/864	30"/762	11.95"/304	23"/584*	45/21	16.5"/420	16"/410	14.5"/370	500W
1850.xxMH	Tornado Marine 1850	→	34"/864	30"/762	11.95"/304	23"/584*	46/21	16.5"/420	16"/410	14.5"/370	500W
1900.xxG	Tornado 1900	↑	38"/965	24"/610	11.95"/304	21"/533	52/24	24.5"/620	16"/410	14.5"/370	600W
1900.xxGV	Tornado 1900	↓	39"/991	30"/762	11.95"/304	23"/584*	60/27	24.5"/620	16"/410	14.5"/370	600W
1900.xxGH	Tornado 1900	→	39"/991	30"/762	11.95"/304	23"/584*	60/27	24.5"/620	16"/410	14.5"/370	600W
1900.xxM	Tornado Marine 1900	↑	39"/991	24"/610	11.95"/304	23"/584*	52/24	24.5"/620	16"/410	14.5"/370	600W
1900.xxMV	Tornado Marine 1900	↓	40"/1016	30"/762	11.95"/304	23"/584*	60/27	24.5"/620	16"/410	14.5"/370	600W
1900.xxMH	Tornado Marine 1900	→	40"/1016	30"/762	11.95"/304	23"/584*	60/27	24.5"/620	16"/410	14.5"/370	600W
1925.xxG	Tornado 1925	↑	42"/1070	27"/690	11.95"/304	21"/533	52/24	28"/710	16"/410	14.5"/370	600W
1925.xxGV	Tornado 1925	↓	43"/1090	30"/762	11.95"/304	23"/584*	60/27	28"/710	16"/410	14.5"/370	600W
1925.xxGH	Tornado 1925	→	43"/1090	30"/762	11.95"/304	23"/584*	60/27	28"/710	16"/410	14.4"/370	600W

Model #	Description	↑ ↓ →	A Height	B Diameter	C Mounting Centers	D Mounting Centers	Weight Lbs/kg	E Luminaire Max Height	F Luminaire Max Width	G Luminaire Base Width	Luminaire Max Watts
1925.xxM	Tornado Marine 1925	↑	43"/1090	27"/690	11.95"/304	21"/533	52/24	28"/710	16"/410	14.5"/370	600W
1925.xxMV	Tornado Marine 1925	↓	44"/1118	30"/762	11.95"/304	23"/584*	60/27	28"/710	16"/410	14.5"/370	600W
1925.xxMH	Tornado Marine 1925	→	44"/1118	30"/762	11.95"/304	23"/584*	60/27	28"/710	16"/410	14.5"/370	600W
1975.xxG	Tornado 1975	↑	45"/1150	27"/690	11.95"/304	21"/533	57/26	30.5"/780	16"/410	14.5"/370	600W
1975.xxGV	Tornado 1975	↓	46"/1168	30"/762	11.95"/304	23"/584*	65/30	30.5"/780	16"/410	14.5"/370	600W
1975.xxGH	Tornado 1975	→	46"/1168	30"/762	11.95"/304	23"/584*	65/30	30.5"/780	16"/410	14.5"/370	600W
1975.xxM	Tornado Marine 1975	↑	46"/1168	23"/584	11.95"/304	21"/533	57/26	30.5"/780	16"/410	14.5"/370	600W
1975.xxMV	Tornado Marine 1975	↓	47"/1194	30"/762	11.95"/304	23"/584*	65/30	30.5"/780	16"/410	14.5"/370	600W
1975.xxMH	Tornado Marine 1975	→	47"/1194	30"/762	11.95"/304	23"/584*	65/30	30.5"/780	16"/410	14.5"/370	600W
2000.xxG	Tornado 2000	↑	45"/1150	32"/820	16.23"/412	28.5"/724	110/50	30.5"/780	21"/530	19.25"/490	1200W
2000.xxGV	Tornado 2000	↓	39"/991	36"/914	16.23"/412	30"/762*	115/55	30.5"/780	21"/530	19.25"/490	1200W
2000.xxGH	Tornado 2000	→	39"/991	36"/914	16.23"/412	30"/762*	115/55	30.5"/780	21"/530	19.25"/490	1200W
2000.xxM	Tornado Marine 2000	↑	39"/991	32"/820	16.23"/412	28.5"/724	110/50	30.5"/780	21"/530	19.25"/490	1200W
2000.xxMV	Tornado Marine 2000	↓	40"/1016	36"/914	16.23"/412	30"/762*	115/55	30.5"/780	21"/530	19.25"/490	1200W
2000.xxMH	Tornado Marine 2000	→	40"/1016	36"/914	16.23"/412	30"/762*	115/55	30.5"/780	21"/530	19.25"/490	1200W
2300.xxG	Tornado 2300	↑	53"/1350	36"/914	16.23"/412	28.5"/724	111/51	38"/970	21"/530	19.25"/490	1700W
2300.xxGV	Tornado 2300	↓	54"/1370	36"/914	16.23"/412	30"/762*	126/57	38"/970	21"/530	19.25"/490	1700W
2300.xxGH	Tornado 2300	→	54"/1370	36"/914	16.23"/412	30"/762*	126/57	38"/970	21"/530	19.25"/490	1700W
2360.xxG	Tornado 2360	↑	53"/1350	36"/914	16.23"/412	28.5"/724	111/51	38"/970	VL6000-specific		
2360.xxGV	Tornado 2360	↓	54"/1370	36"/914	16.23"/412	30"/762*	126/57	38"/970	VL6000-specific		
2360.xxGH	Tornado 2360	→	54"/1370	36"/914	16.23"/412	30"/762*	126/57	38"/970	VL6000-specific		
2300.xxM	Tornado Marine 2300	↑	54"/1370	36"/914	16.23"/412	28.5"/724	111/51	38"/970	21"/530	19.25"/490	1700W
2300.xxMV	Tornado Marine 2300	↓	55"/1397	36"/914	16.23"/412	30"/762*	126/57	38"/970	21"/530	19.25"/490	1700W
2300.xxMH	Tornado Marine 2300	→	55"/1397	36"/914	16.23"/412	30"/762*	126/57	38"/970	21"/530	19.25"/490	1700W
2400.xxG	Tornado 2400	↑	61"/1530	42"/1067	19.48"/495	34.50"/876	204/93	44"/1120	28"/710	24.25"/615	2500W
2400.xxGV	Tornado 2400	↓	62"/1575	42"/1067	19.48"/495	36"/914*	209/95	44"/1120	28"/710	24.25"/615	2500W
2400.xxM	Tornado Marine 2400	↑	61"/1530	42"/1067	19.48"/495	34.50"/876	204/93	44"/1120	28"/710	24.25"/615	2500W
2400.xxMV	Tornado Marine 2400	↓	62"/1575	42"/1067	19.48"/495	36"/914*	209/95	44"/1120	28"/710	24.25"/615	2500W
2500.xxG	Tornado 2500	↑	67"/1700	48"/1220	19.48"/495	34.50"/876	209/95	52"/1320	28"/710	24.25"/615	3000W
2500.xxGV	Tornado 2500	↓	68"/1725	48"/1220	19.48"/495	36"/914*	214/97	52"/1320	28"/710	24.25"/615	3000W
2500.xxM	Tornado Marine 2500	↑	67"/1700	48"/1220	19.48"/495	34.50"/876	209/95	52"/1320	28"/710	24.25"/615	3000W
2500.xxMV	Tornado Marine 2500	↓	68"/1725	48"/1220	19.48"/495	36"/914*	214/97	52"/1320	28"/710	24.25"/615	3000W

Airflow Clearance

Observe the minimum clearances shown around your enclosure

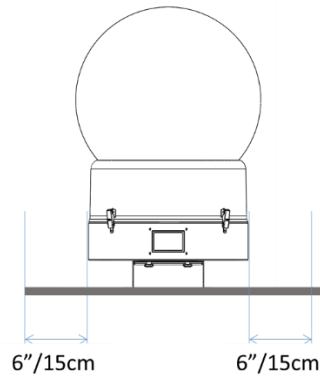

Snow Clearance

In areas where snow is likely, make sure the base of the enclosure is at least 24" [60cm] above highest potential snow drift level.

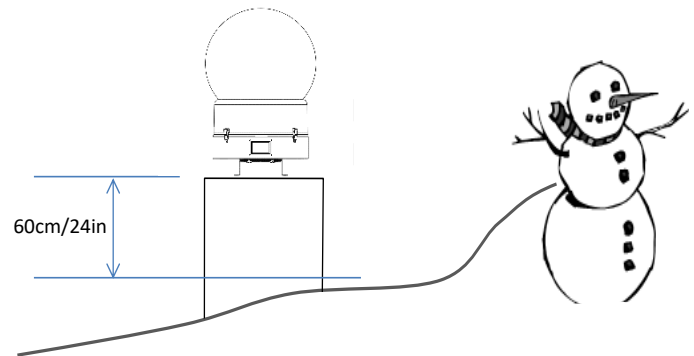

Mounting Hardware Options

Mounting Bolts

1. DO NOT DISCARD THE BOLTS ATTACHING THE ENCLOSURE TO THE SHIPPING PALLET
2. Each Enclosure must be mounted with FOUR points.
3. Mountings must be made using M12 or ½" bolts
4. Tempest recommends the use of stainless steel mounting hardware.
5. Bolt enclosure to a stable structure capable of supporting the weight of the enclosure plus the luminaire enclosed.

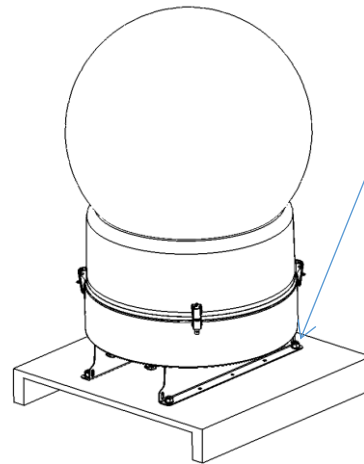

⑩ M12-1.75 x 40 bolts, washers, nuts
DO NOT DISCARD!



NOTE:
Globe Down and Horizontal enclosures also supplied with Unistrut Spring nuts.



Globe Down Tornado Enclosures

6. Bolt the Tornado enclosure to a suitable overhead structure using the bolts and Unistrut spring nuts supplied
7. To hang from a lighting truss, use four hanging clamps or half-couplers, bolted to Unistrut spring nuts
8. Screw the eyebolts supplied into the center threaded holes in the Unistruts and secure to the overhead structure or truss with a safety cable (not supplied) rated for 5 x the total weight of the Tornado enclosure plus luminaire.

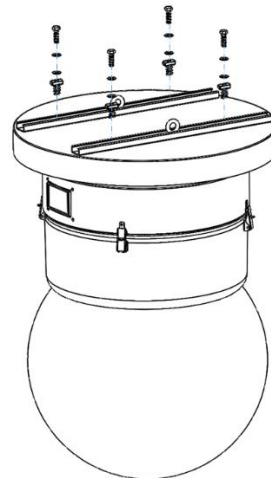

⑥ Use the M12 bolts, washers and Unistrut spring nuts provided to attach globe-down Tornado enclosures to a suitable overhead support.

Horizontal Tornado Enclosures

9. Bolt the Tornado enclosure to a suitable overhead structure using the bolts and Unistrut spring nuts supplied – see illustration (6).

IMPORTANT SAFETY NOTICE

Installer must ensure that all mounting points are secure and conform to local safety regulations. Tempest Lighting Inc. accepts no responsibility for damage or injury arising from inappropriate or unsafe installation.

⑧ Safety cable Eyebolts

⑦ Attach hanging clamps or half couplers to the Unistrut rails to hang Tornado from a lighting truss

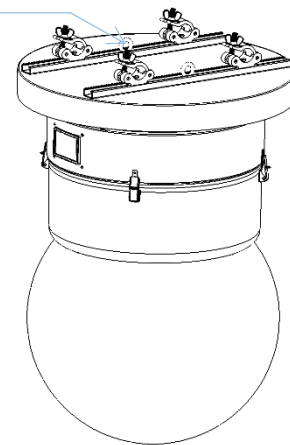

Drainage

For base up/globe down or horizontal operation, a small drainage hole should be drilled in the globe, to permit any water draining through the enclosure to exit harmlessly.

Note: this is not required in sheltered installations, such as under an overhang or canopy.

YOU MUST USE THE APPROPRIATE TAPERED DRILL BIT.

A tapered drill bit is included with the printed manual packet in each Tornado shipment.

Replacements are available from Tempest free of charge.

A standard drill bit may crack the plexiglass globe. Tempest Lighting will not be responsible for such damage.

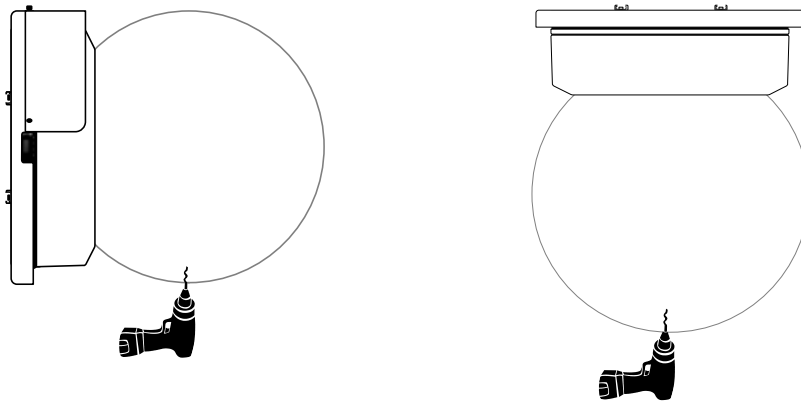

Horizontal Enclosures – be sure to replace the globe with the drainage hole at the lowest point after relamping.

Wiring the Enclosure

Power Wiring

SAFETY NOTICE

All power wiring must be performed by a competent electrician, appropriately licensed in the jurisdiction where the installation takes place. All electrical work must be done in full compliance with all electrical and safety norms applicable to the installation site. Isolate all power feeds before opening the enclosure.

Tempest Lighting, Inc., its employees and agents will not be held responsible for damage or injury caused by disregarding this notice.

Electrical Standards

Important:

Enclosure model numbers including **.US** are for use in countries using US and Japanese style electrical systems:

200-208VAC 50/60Hz

Enclosure model numbers including **.IN** are for use in countries using European style electrical systems:

220-250VAC 50/60Hz

Note:

- (1) All Tornado and Tornado Marine G4 exhaust fans are 120VAC, regardless of electrical standard. The control electronics provide a variable ac supply to the exhaust fans up to 120V.
- (2) Heaters are rated 200-250V, dependent on electrical standard.
- (3) Electronics are autosensing for any voltage 90-265VAC, 50/60Hz
- (4) ***Tornado enclosures may be supplied wired for 120V operation to special order.***

Local Isolator Switch

Tempest strongly recommends installing a local 2-pole isolator switch on the AC power supply to the enclosure, so that technicians may safely perform maintenance on the enclosure and its contents. In some jurisdictions this is a code requirement.

Use lockout and tagout procedures in compliance with local electrical codes and safe working practices.

If using the split power feed feature, two isolators will be required.

ALWAYS ISOLATE POWER TO THE TORNADO ENCLOSURE WHEN PERFORMING INSTALLATION OR MAINTENANCE WORK WITH THE GLOBE REMOVED.

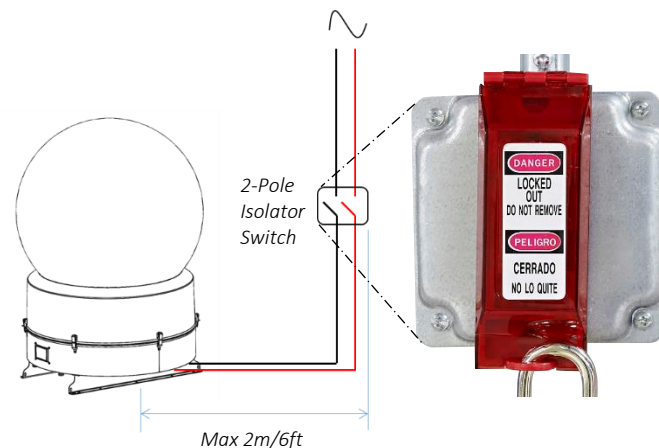

Wiring Access – Globe-up Models

Locate the two Conduit entry holes on the underside of the enclosure:

Conduit openings accept PG21 (International) and $\frac{3}{4}$ " NPT (North America) conduit fittings.

Use permanent or flexible, outdoor rated, conduit to connect power and signal cables to your Tornado enclosure.

ALWAYS RUN POWER AND SIGNAL CABLES IN SEPARATE CONDUITS.

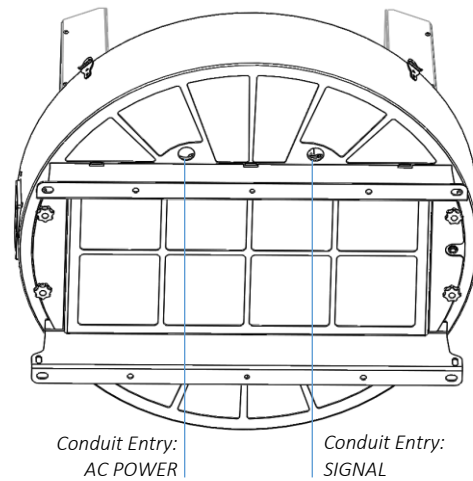

Wiring Access – Globe-down and Horizontal Models

Locate the two Conduit entry holes on the enclosure rain guard:

Conduit openings accept PG21 (International) and $\frac{3}{4}$ " NPT (North America) conduit fittings.

USE LIQUID-TIGHT CONDUIT FITTINGS OR CABLE GLANDS.

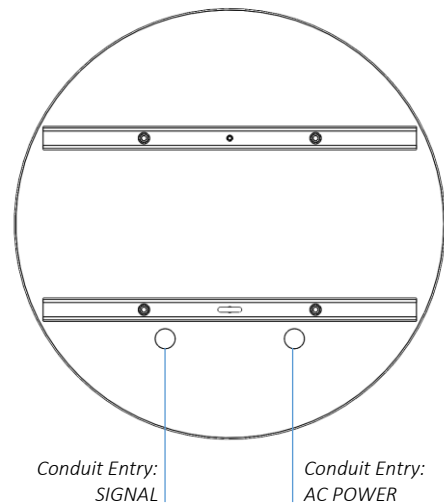

Use permanent or flexible, outdoor rated conduit to connect power and signal cables to your Tornado enclosure.

Use the plastic sleeves supplied to protect cables between the conduit fittings and the internal wiring terminals.

ALWAYS RUN POWER AND SIGNAL CABLES IN SEPARATE CONDUITS.

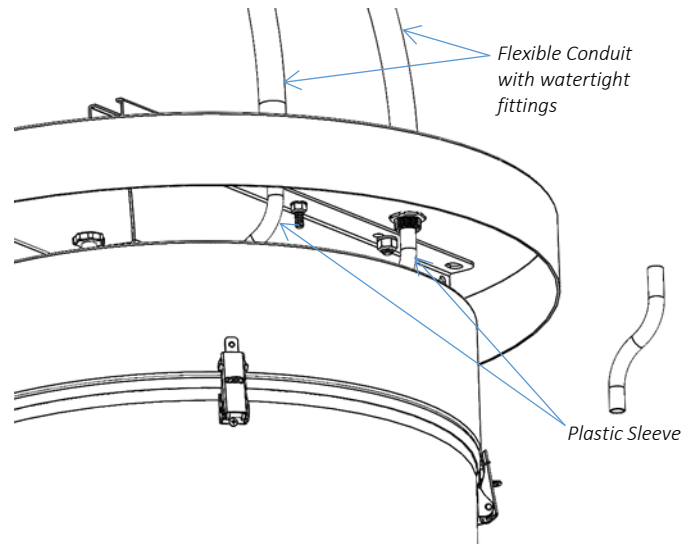

Remove the DEC4 Controller cover.

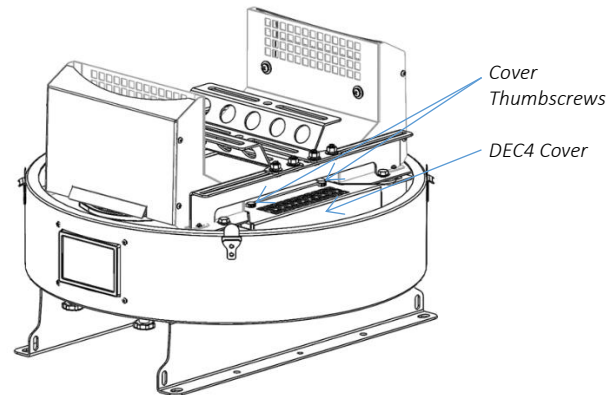

Identify the following parts:

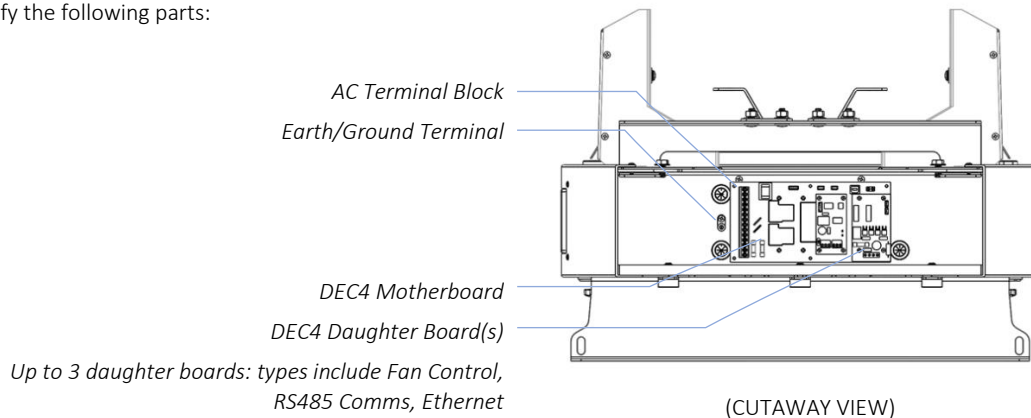

One or Two Power Circuits?

Tempest enclosures may be wired on single or double circuit supplies. On a single feed, both enclosure and luminaire are permanently on. With a split (double) feed supply, you can switch off the luminaire when not in use, while the enclosure continues to protect it 24/7.

Tip: most people use single feed.

Tip: even wired for single feed, you can use DMX to switch the luminaire power on and off – see the DEC4 section below.

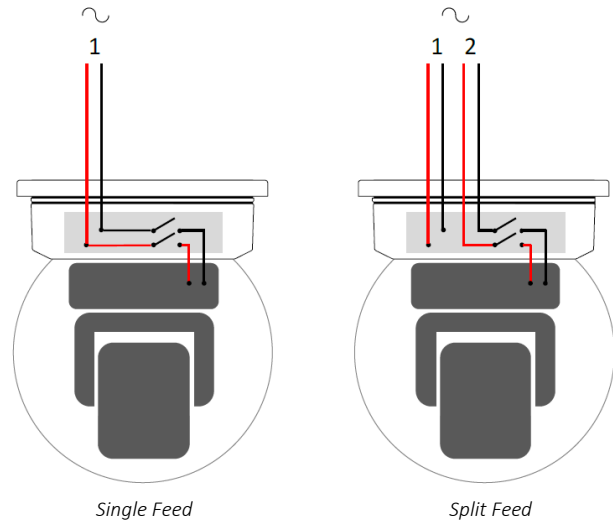

Single Feed

- Enclosure and luminaire are permanently on.
- Enclosure and Luminaire must be rated for the same voltage.
- Supply must be rated for luminaire current plus 150 watts.
- Supply must be permanently ON.

Split feed

- Enclosure power must be permanently ON.
- Luminaire power may be switched off.
- Enclosure power must be rated for:
 - Tornado 1850-1975: 650 watts
 - Tornado 2000-2300: 1150 watts
 - Tornado 2400-2500: 2000 watts
- Luminaire power must be rated for the luminaire (see luminaire manual).

For **single feed** wiring, **no modification** to the DEC4 Controller motherboard is needed.

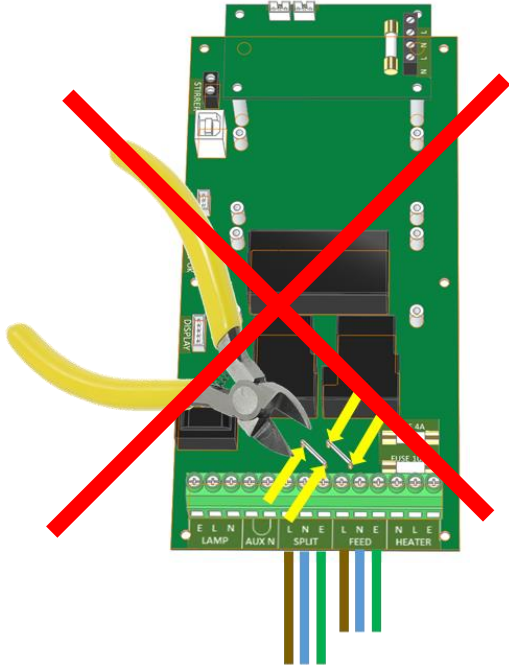

Single Feed Power Termination

- Connect Earth/Ground wire to Ground Terminal
- Connect Live and Neutral to the terminals marked FEED

IMPORTANT:

For **split feed** wiring, use a side cutter to cut both AC links at both ends:

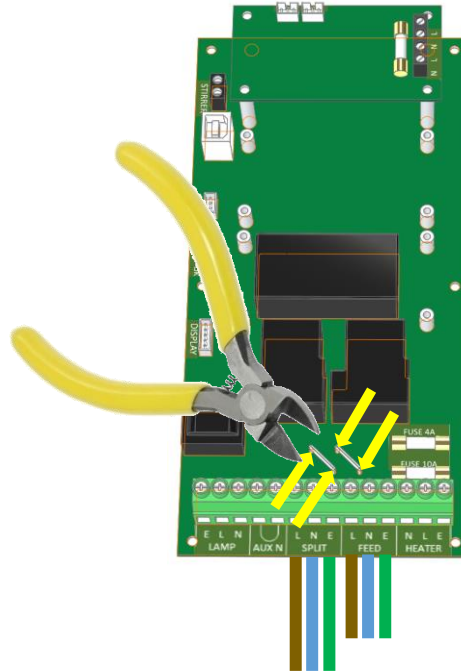

Split Feed Power Termination

- **STOP!** Did you cut the power links? See above.
- Connect Earth/Ground wire to Ground Terminal
- Connect Enclosure feed to the terminals marked FEED
- Connect Luminaire feed to the terminals marked SPLIT

SEE WIRING DIAGRAMS BELOW

AC Supply Voltage

Tempest Tornado enclosures require supply voltage in the nominal range 200-250VAC, 50/60Hz.

- North American installations – use a 208V supply (2 x 120V hots), and connect one hot to Line and one to Neutral terminals.
- North American 120V versions are available to special order.

Wiring – North America/Japan 200-208VAC

Note: For clarity, internal wiring is not shown.

Single Feed

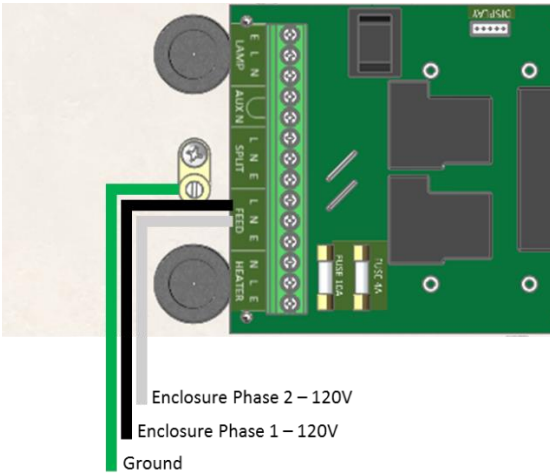

Split Feed

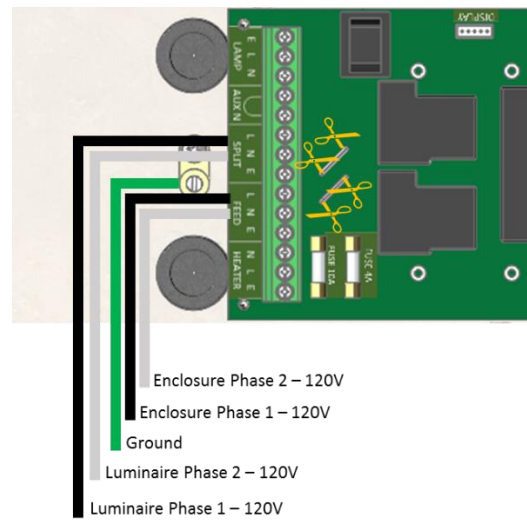

Wiring – International 220-250VAC

Note: For clarity, internal wiring is not shown.

Single Feed

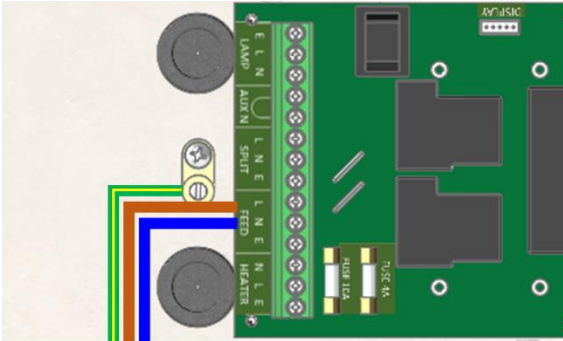

Enclosure Line – 230V
 Enclosure Neutral – 230V
 Earth

Split Feed

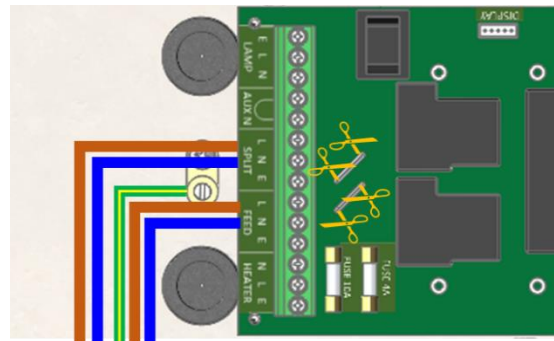

Enclosure Line – 230V
 Enclosure Neutral – 230V
 Earth
 Luminaire Line – 230V
 Luminaire Neutral – 230V

Remote Monitoring Connections

Tempest G4 enclosures optionally support four types of remote monitoring:

1. Direct via Ethernet, using Tempest TEMP protocol (see Appendix – TEMP Protocol)
Requires 51.EN Ethernet board
2. Grouped via RS485, using an Ethernet bridge and Tempest TEMP protocol (see Appendix – TEMP Protocol)
Requires one 51.485 RS485 board per enclosure and one 51.EN Ethernet board per bridge
3. Grouped via RS485, using DMX/RDM – see next page
Requires one 51.485 RS485 board per enclosure, and one JESE RDM-TRI Interface

Direct Ethernet Monitoring Network

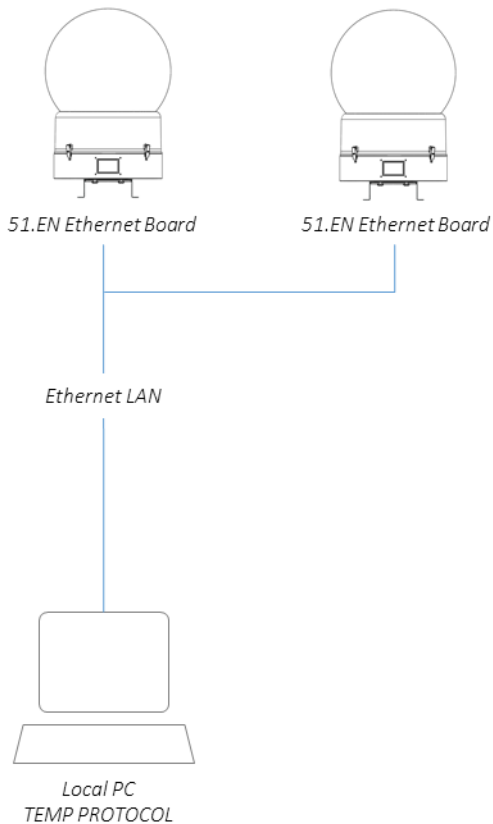

See Appendix for TEMP protocol programming information.

Line Termination Switch Settings

1. DMX/RDM control over RS485:

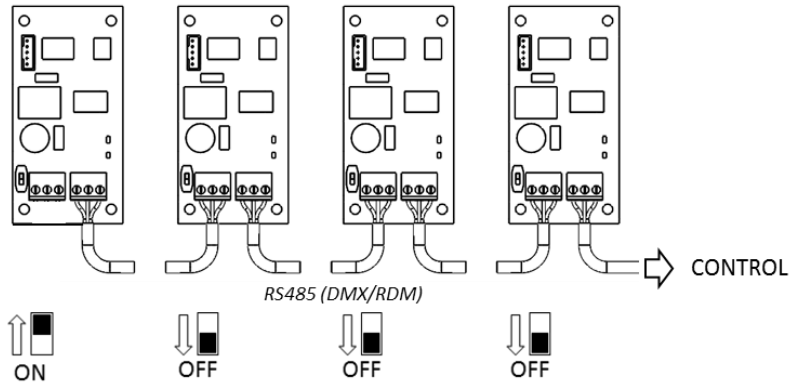

2. TEMP Control of an enclosure group via Ethernet

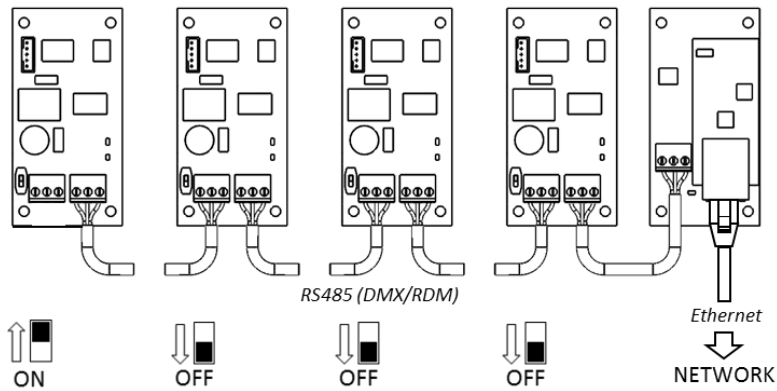

3. TEMP Control of a single enclosure via Ethernet

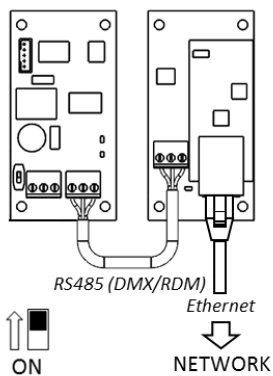

DEC4 Ethernet Adapter – 51.EN

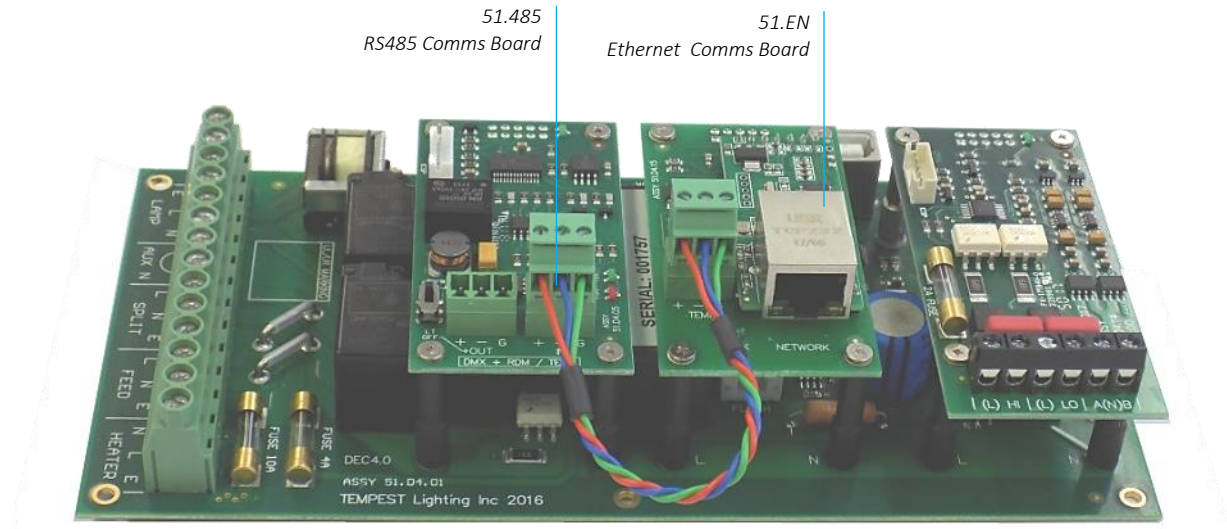

As a default, DEC4 communicates using DMX512 and RDM, over RS485.

With the addition of the 51.EN Ethernet board, any DEC4 – or any group of DEC4 boards connected using RS485 – may be connected to an Ethernet network – see above.

Default Configuration

The bridge module is supplied in DHCP TCP port server configuration, with all traffic on port 3308. These settings may be changed with a web browser on port 80 at the DHCP assigned address. Login to the home page using 'admin' for user name as password.

The bridges may be discovered with a UDP broadcast on port 1500 and a payload of

```
(Hex) 30 31 32 33 34 35 36 37 38 39 30 31 32 33 34 35 36 37 38 39
      30 31 32 33 34 35 36 37 38 39 30 31 32 33 34 35 36 37 38 39
```

The bridge will respond from its DHCP address

Additional Support

The network IP is developed by Jinan USR, more details and software configuration utilities may be found by visiting their web site at <https://www.usriot.com>

Tempest Equipment Management Protocol

TEMP allows you to access status information and set configuration values on DEC3.3 and DEC 4 enclosure controllers, using the 51.EN Ethernet Adapter, over an Ethernet network.

Download the Developer Guide at
www.tempest.biz/tech_support

IMPORTANT:

Tempest warrants that, if correctly implemented, TEMP will provide a reliable and accurate method of monitoring Tempest DEC3 and 4 controllers over an Ethernet network. However, the integrator is entirely responsible for the connection between the Ethernet Bridge and the network.



DMX/RDM Monitoring Network

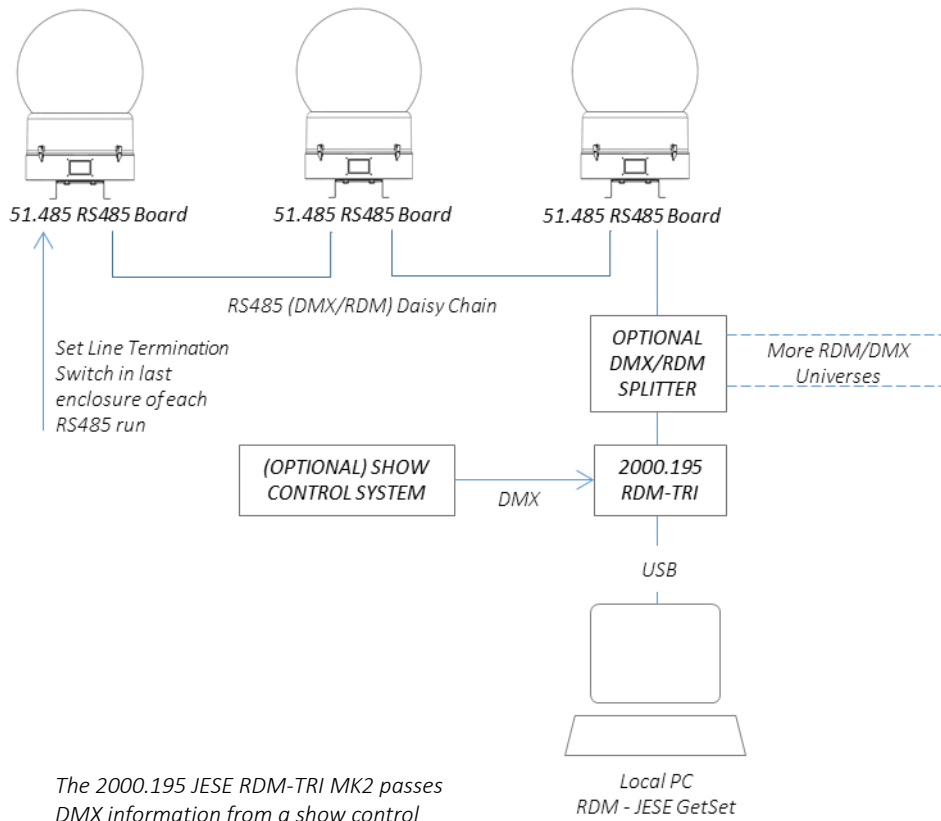

The 2000.195 JESE RDM-TRI MK2 passes DMX information from a show control system to each DEC4 controller.

Set a DMX address for each controller in the range 1-510. See DEC4 section below for more information.

Note: Tempest System Manager and web-based monitoring will be available early 2017

RS485 (DMX/RDM) Cable Terminations

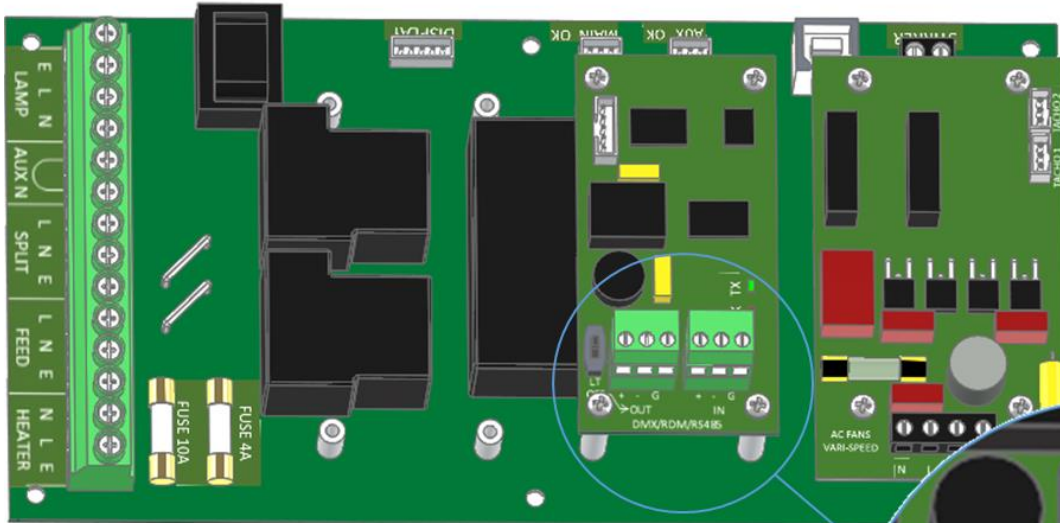

Loop a shielded twisted pair cable (eg Belden 9841, though many people now use a CAT5e cable) from the control/monitoring point, around all enclosures.

Maximum total cable length is 1,200M (4,000ft). For longer runs and widely distributed systems, use a DMX/RDM splitter (make sure that it supports RDM) and multiple cable runs.

Use the termination switch to terminate each RS485 cable run at the last enclosure on each run.

RS485 Line Termination (LT) Switch:
TERMINATED

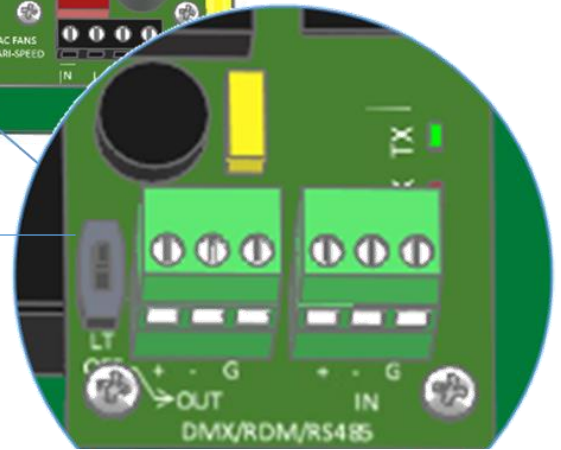

Data + Data - Common Data + Data - Common

DATA OUT

DATA IN

Luminaire Power Control using DMX512

The DEC4 controller includes a 30A 2-pole relay that protects the enclosed equipment in the event of a serious high temperature event by cutting off power.

You may use DMX512 to control power to the luminaire inside the enclosure. This is very useful in hot locations, where the luminaire may be stressed by being held in standby mode all day under hot sun. By powering the luminaire down it will tolerate much higher temperatures without harm.

Tempest recommends the JESE RDM-TRI interface to monitor enclosure status in any installation and control the enclosure power relay in smaller systems.

More complex installations are very likely to include some kind of show control system that will certainly include DMX control. This is the preferred method of controlling power to the luminaires.



Tempest recommends the JESE SH8 DMX/RDM Splitter for large or complex RS485 networks.

JESE RDM-TRI interface connects to a PC via USB to monitor and control a network of Tempest enclosures.
Tempest Item # 2000.195



Digital Enclosure Control

DEC4™ – that’s Digital Enclosure Control, fourth Generation – is the brain of your Tempest enclosure. It will maintain the internal environment in a comfortable temperature and humidity range, and prevent condensation – the real killer of outdoor equipment. DEC4 monitors internal and external temperature, humidity and lamp current at all times, and uses this information to control the enclosure’s lamp relay, fan(s) and heater(s). It can report back over an RS485 network, using the RDM protocol (Remote Device Management), or connect to your TCP/IP network for remote monitoring and management using Tempest’s TEMP protocol.

Typical DEC4 configuration, with Motherboard, fan control board and RS485 comms board

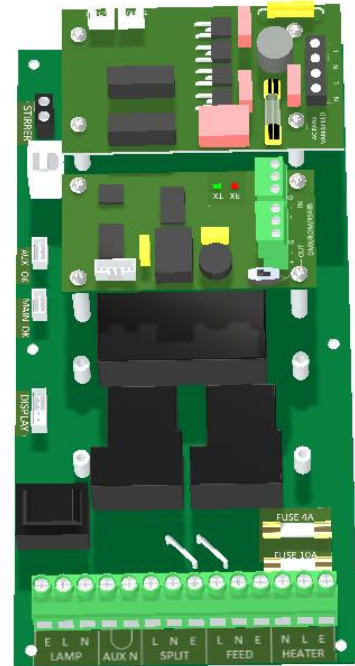

Schematic

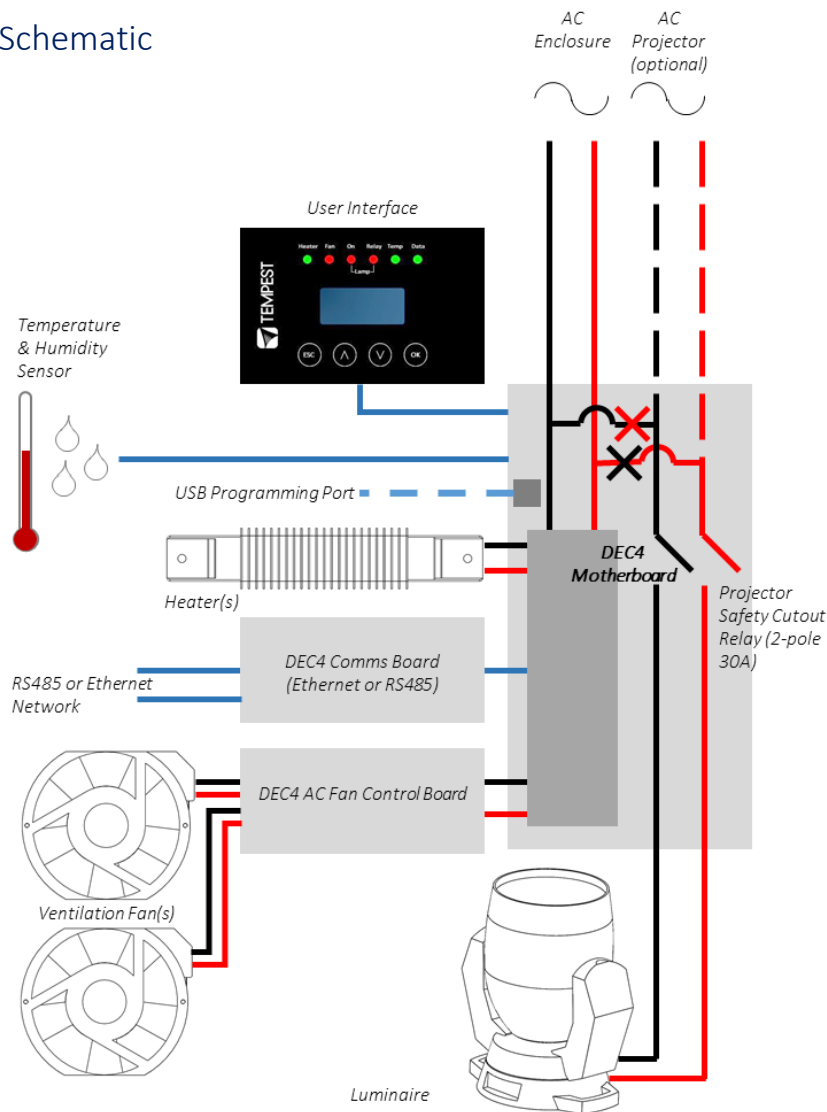

DEC4 Main Functions

1. Sense current to luminaire (lamp on/off)
2. Record lamp hours
3. Monitor temperature and humidity inside Enclosure
4. Monitor temperature outside enclosure
5. Maintain internal temperature at safe operating level
6. Maintain relative humidity within safe limits to prevent condensation
7. Isolate luminaire in case of unsafe temperature
8. Report status over RS485, RDM, TCP/IP
9. Maintain positive pressure (optional) 24/7 to prevent ingress of salt air and other contaminants
10. Circulates air internally to prevent hot and cold spots when luminaire is idle

DEC3.3 constantly monitors the following parameters:

- Luminaire/Luminaire current
- Line Voltage
- Temperature
- Humidity

DEC 3.3's patented Goldilocks™ algorithm uses a combination of sensors, heaters and fans to maintain a safe operating temperature and a safe relative humidity level that will not allow condensation to take place.

As air is heated it is able to support more moisture without condensing, so Goldilocks uses heat to raise the air temperature inside the enclosure in the event that relative humidity approaches dewpoint.

Factory Settings – Basic Mode

In most applications, DEC3.3 will operate correctly with its factory default settings, in Basic operating mode.

You do not need to do anything. Please skip to the Power Connections section below.

- Standard default temperature and humidity settings
- DMX, RDM and Remote Monitoring disabled
- Best for standalone operation
- Supports TEMP remote monitoring – see appendix

If your needs are more complex, read on.

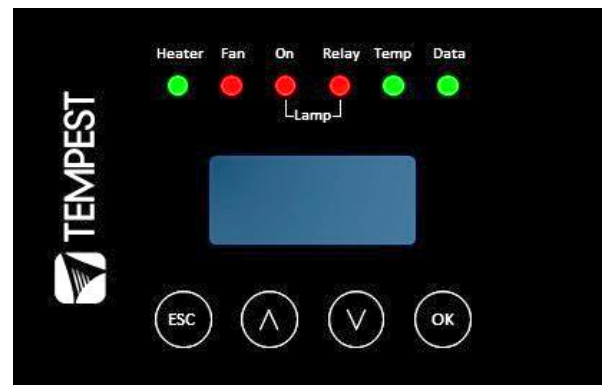

Other Operating Modes

Monitor Mode

As Basic mode, plus:

- RDM status reporting over RS485
- RDM configuration – settings may be changed remotely or at the enclosure control panel

Control Mode

As Basic mode, plus:

- Enclosure functions as a 1-channel DMX device, with remote control of the lamp relay
 - DMX level > 75% enables normal relay operation (normally ON)
 - DMX level < 25% disables normal relay operation (relay turns OFF)
 - This allows you to force a hard reset of the lamp relay in the event of a luminaire malfunction
- Control mode is recommended for show control applications, but can be risky in live show operation, since the DMX slot used for the enclosure MUST be kept high to prevent the lamp relay from opening.

Service Mode

For trained service personnel only

- Normal operation is suspended and the enclosure functions as a 3-channel DMX device:
 - Lamp Relay (Slot 1)
 - Fans (Slot 2)
 - Heater (Slot 3)
- Service mode is ONLY for troubleshooting – DO NOT use Service mode for normal operation.

DEC4 Control Parameters

Temperature and Humidity Ranges

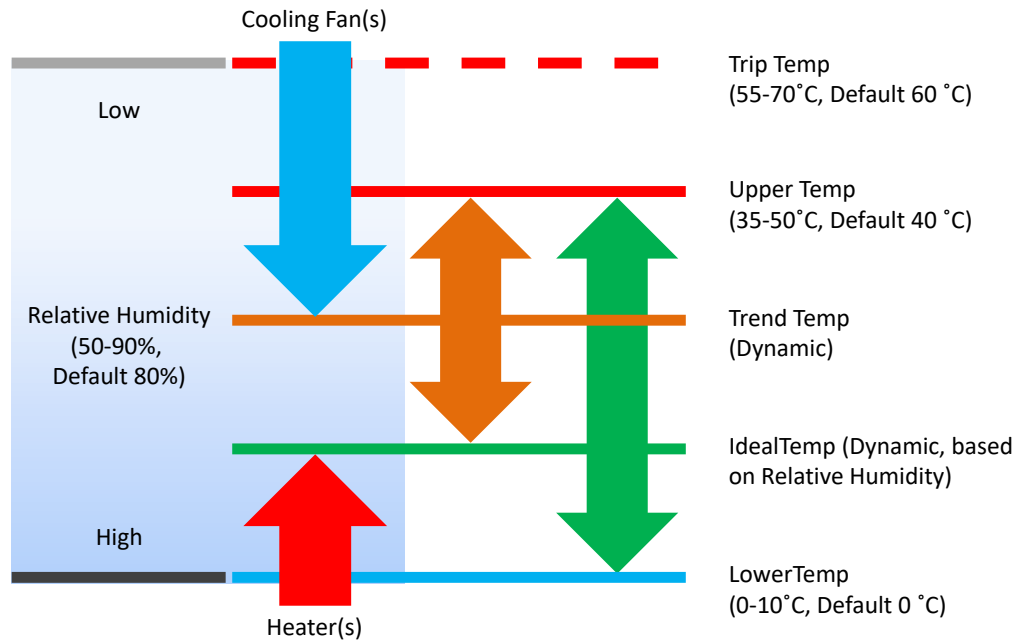

Notes:

- 1 In moving light enclosures the temperature sensor is located in the exhaust airflow. Temperatures shown may be higher than those around the luminaire.
- 2 We recommend using the factory default settings for several weeks or months before making any changes. In most cases they will not be necessary.

Control Interface

LED Indicators

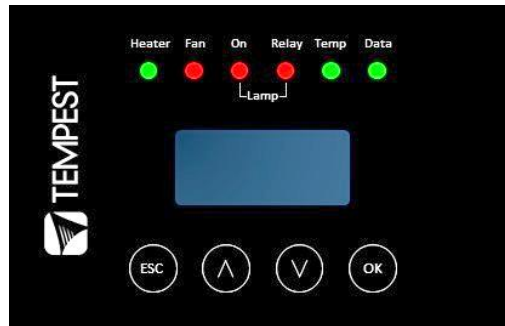

Heater	ON (Green) 	Heater is ON, to maintain lower temperature level or to prevent condensation
Fan	ON (Green) 	Lamp is ON, or Temperature is HIGH and Fan is cooling enclosure. Short burst when lamp off indicates fan moving air to stabilize temp/humidity
Lamp On	ON (Green) 	Current sensing shows lamp is ON Lamp hour counter is running
	OFF	Current sensing shows lamp is OFF Lamp hour counter is not running
Lamp Relay	ON (Green) 	Lamp relay is closed (normal) Luminaire power receptacle is energized
	ON (Red) 	Lamp relay is open due to over-temperature event. Luminaire power receptacle is isolated.
Temp	FLASHING (Green) 	Temperature is below lower temp setting
	ON (Green) 	Temperature is in normal range
	ON (Amber) 	Humidity is above target limit
	ON (Red) 	Temperature is above top setting
	FLASHING (Red) 	Temperature is above Trip level Luminaire power is isolated
Data	OFF	DEC4 is in BASIC Mode – Data not used. OR DEC4 is in TEMP, Monitor or Control Mode and no valid data packet has been detected.
	ON (GREEN) 	Good data packet received.
	ON (RED) 	Control Mode: Data Fail. A previously good data signal has failed. Monitor Mode: No RDM information being received (this is normal)

User Interface LCD Display

The display on the Control display provides additional status information, depending on the operating mode:

Basic Mode & Monitor Mode

28 °C	47%	<i>internal temperature, relative humidity</i>
209V	OFF	<i>line voltage, lamp status</i>

DMX Mode & Service Mode

28 °C	47%	<i>internal temperature, relative humidity</i>
209V	OFF	<i>line voltage, lamp status</i>

Alternating with:

DMX: 001	<i>DMX Start Address</i>
No DMX	<i>DMX Status</i>

Control Interface Operation

The Control Interface is normally LOCKED.

- To UNLOCK, hold **ESC** and **OK** together for **5 seconds**.
- You are now in the CONTROL MENU
- Use **↑↓** to scroll up and down the menu.
- Press **OK** to enter a menu item
- Use **↑↓** to set the item parameter, or to scroll to the next menu level.
- Use **ESC** to go BACK, or **OK** to confirm settings (**↵**).
- To LOCK, hold **ESC** for 5 seconds.

Menu will time out after ten minutes.

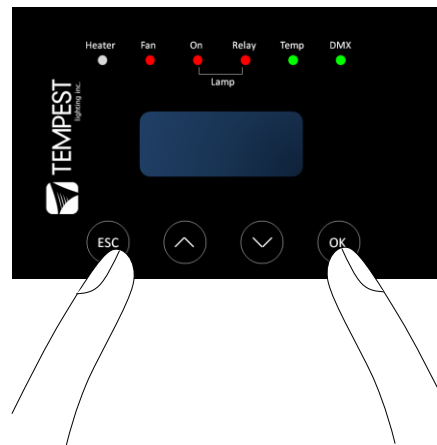

Control Menu

Set DMX Options

SET DMX MODE

From the Front Panel, this menu item allows the user to check (and if necessary change) the RDM mode.

BASIC	Standalone operation, no DMX/RDM (factory default)
MONITOR	Standalone, plus support for RDM remote configuration and monitoring
CONTROL	Monitor, plus use of a single DMX slot to control Lamp relay
TEMP	Same as Basic, but supports remote monitoring over RS485 with Ethernet adapter and Tempest TEMP protocol
SERVICE	Monitor, plus use of three DMX slots to control Lamp, Heater and Fan

Important: Please ensure that the DEC3.3 is NOT left in Service Mode.

SET DMX ADDRESS (in Monitor, Control or Service modes)

Select a DMX starting address in the range 001 to 510

1 – Lamp Relay

In Service Mode an addition two slots are available

2 – Fan Duty Control

3 – Heater Duty Control

Note that the DMX control is designed using a SAFETY pile-on Logic. So the DMX input can only override automatic settings within safe limits.

SET DMX CURVE

DMX Curves affect the way the fixture relay is controlled in Control Mode.

DMX levels are shown as %.

Response Curve 1 (default)

DMX level 0-25 Relay disabled (open)

DMX level 26-75 No change to relay status

DMX level 76-100 Relay enabled (normally closed)

Response Curve 2

DMX level 0-19 No change to relay status

DMX level 20-40 Relay disabled (open)

DMX level 41-59 No change to relay status

DMX level 60-80 Relay enabled (normally closed)

DMX level 81-100 No change to relay status

SET DMX RESPONSE

DMX Response sets a delay time before DMX Control Mode settings are acted on. Setting a response delay of a few seconds would prevent unintended fixture relay state changes in the event of a short accidental change in DMX level.

NOTE: from firmware revision 0.00.100, DEC holds last valid DMX level if DMX is interrupted.

Response Delay Values are:

No Delay (default), 1, 2, 5, 10, 15, 20, 30, 60 seconds.

Set Temp Units

Choose to display temperature values in Celsius or Fahrenheit (default Celsius)

Note that temperature settings must be entered in Celsius.

Set Temp Ranges

Set three temperature trigger points for Bottom, Top and Trip temperatures, in °C.

SET TEMP LOWER (minimum temperature to be maintained)

(default 0°C, permissible range 0-10°C).

SET TEMP UPPER (maximum desired temperature)

(default 40°C, permissible range 35-50°C).

SET TEMP TRIP (temperature at which load will be isolated – see note)

(default 60°C, permissible range 55-70°C).

Note: A thermal emergency is when enclosure ventilation fails with the lamp on, in which case the temperature will rise very quickly. To avoid nuisance tripping we recommend setting a higher Trip temperature, 60°C or above.

Set Lamp On Point

The lamp current at which DEC detects the luminaire/luminaire lamp is running. Default is 1 Amp, which allows for equipment fans and power supplies to run without changing the air in the enclosure. Lamp on point may be set in 0.2 Amp increments between 0.2 Amps and 2.0 Amps.

Reset Lamp Hours

Reset each time you change the lamp in the luminaire.

Make this a part of your maintenance instructions.

Status Display

View current status information, using the arrow keys to scroll through:

- a) Humidity – relative humidity in %
- b) Air temperature, in degrees C or F
- c) PCB temperature (this will usually be significantly higher than air temperature)
- d) Voltage – line Voltage reaching the DEC
- e) Current being drawn by luminaire/light, in Amps
- f) Lamp Hours elapsed since last reset
- g) Firmware version

Safe Mode

In certain circumstances, the DEC User Interface may display the message SAFE MODE. This can happen if the Humidity sensor stops reporting, or reports an extreme value, indicating the probability of a sensor error. This situation may arise either because of a faulty sensor* or in conditions of extremely high absolute humidity.



In SAFE MODE, the normal Goldilocks operation is temporarily suspended, and the enclosure works to return the internal environment to a condition from which normal operation may be resumed.

SAFE MODE is SAFE! It indicates that attention may be needed, but not that your equipment is at risk.

** Some sensors shipped before mid-2017 have had a limited operational life in harsher conditions. Tempest has since developed a new class of capacitive sensor that is far more resilient, especially in demanding conditions.*

The new class of sensors (MG Type) have either:

- a) A piece of green tape on the sensor cable

And/or

- b) TEMPEST logo on the plastic sensor case

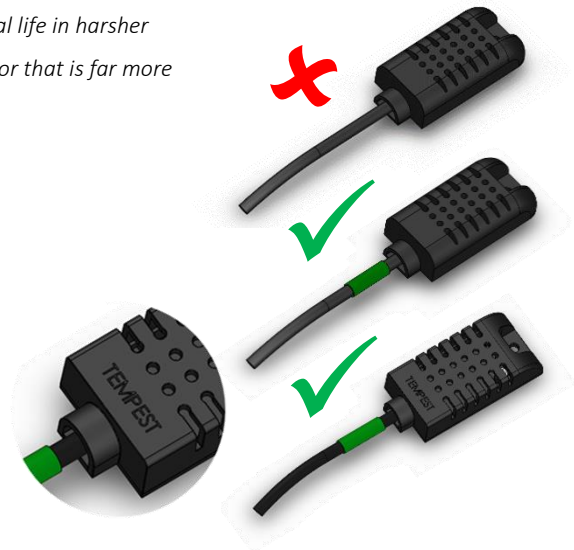

Safe Mode – What to do:

If you see **SAFE MODE** on your User Interface Display:

1. Check the temperature/humidity sensor:
 - a. If it does NOT have either a Tempest logo or a piece of green tape on the cable, contact Tempest for a free-of-charge replacement. If you have more than one enclosure, we suggest replacing the sensors on ALL your enclosures.
2. If the sensor has either a Tempest logo or a piece of green tape on the cable, then:

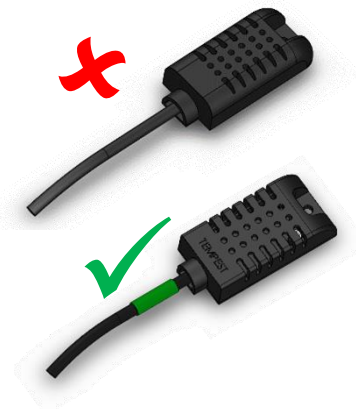

- a. Check that the sensor cable is not damaged and that it is plugged in to the header on the DEC Mother board labeled MAIN
- b. Check the actual climate conditions – could the absolute humidity be close to 100%? If it is, SAFE MODE is operating correctly, and all is well.



Mounting the Luminaire

Luminaire Base Handles

The distance between the fan/heater chimneys is limited.

Dimension G:

Tornado 1850-1975	14.5"/370mm
Tornado 2000-2300	19.25"/490mm
Tornado 2400-2500	24.25"/615mm

In some cases, it will be necessary to remove the handles from the luminaire base to fit it between the chimneys.

Follow the luminaire manufacturer's service instructions to remove the base handles before installing the luminaire.

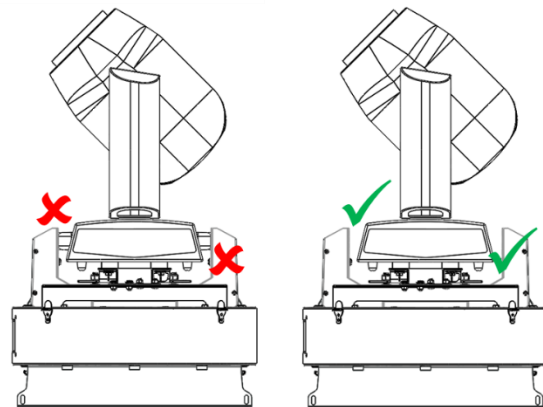
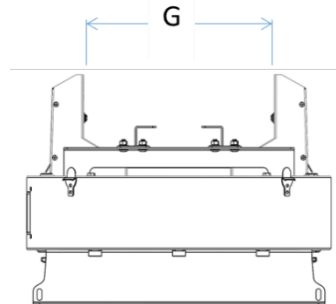

Mounting Bars

Tornado's luminaire mounting system is extremely flexible. Its stainless steel construction resists corrosion in any environment and is very robust.

The mounting bars may be configured in four different ways, depending on the luminaire size and chosen mounting method (see below).

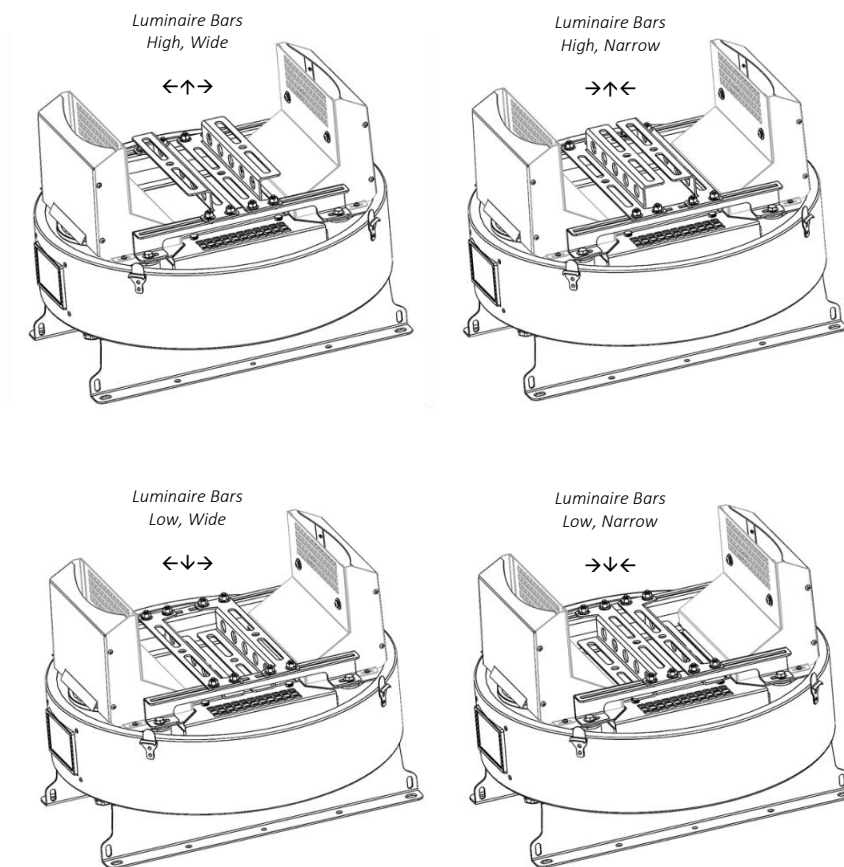

Mounting The Luminaire

Moving lights from different manufacturers come with various different mounting options, all of which will install readily to Tornado's luminaire mounts.

1. To mount the luminaire, first remove the two mounting bars, by removing the 8mm nuts and carriage bolts.
2. Choose the mounting method below:

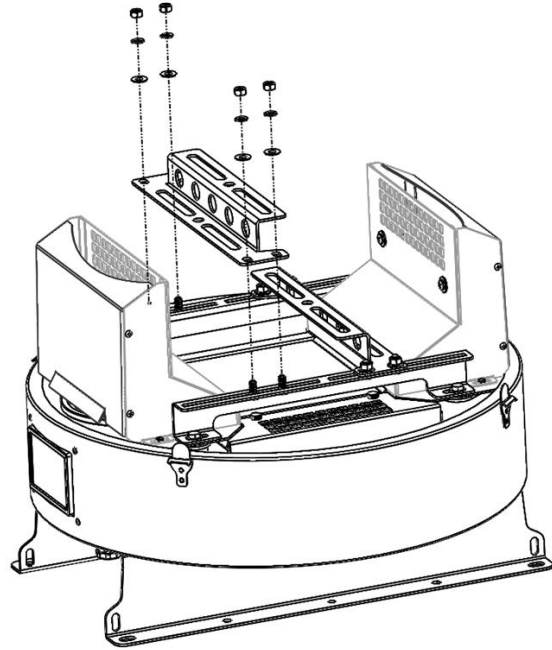

Omega Clamps

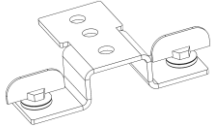

Most luminaires come with omega clamps of some kind, and this is the easiest mounting method.

1. Simply bolt the omega clamp to the two luminaire mounting bars. *Note: This will probably work best in one of the LOW positions (shown here), due to the height of the omega brackets.*
2. Check that the luminaire is centered and that the ends of the mounting bars are parallel.

NOTE: In some cases, you may need to add a nut under the omega clamp, to clear the omega handle.

NOTE: This mounting method may not provide maximum rigidity. Some luminaires might be unsteady when stopping at the end of rapid moves.

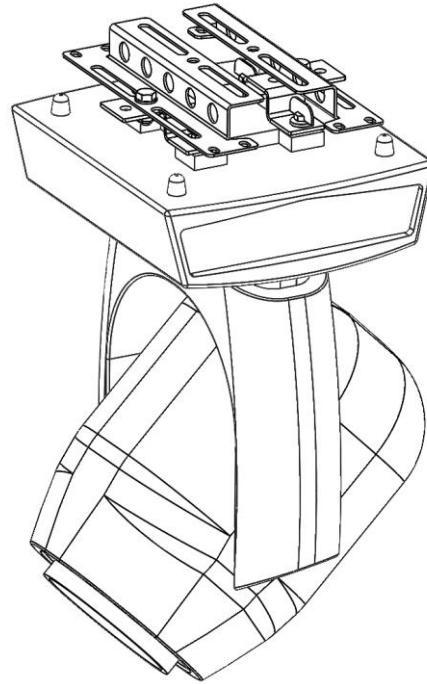

Example – Clay Paky Super Sharpy/Mythos.

1. Bolt the center hole of the mounting bar (wide side) to the center hole of the omega clamp, using the M10 bolts provided. *Using this side of the mounting bar ensures that the height of the omega clamps will not raise the luminaire too high in the enclosure.*
2. Secure the omega clamp to the luminaire base using the two quarter-turn fasteners provided.

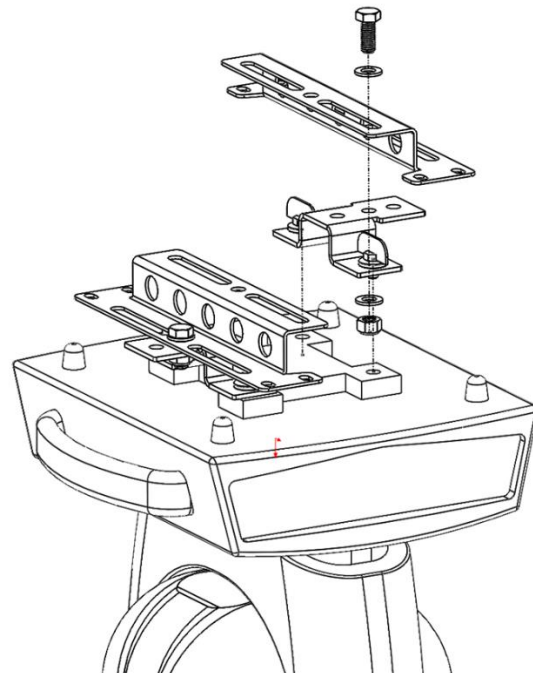

Screws

Many luminaire bases incorporate threaded holes for mounting screws.

1. Simply screw into the luminaire base using the appropriate screws (not supplied).
2. Check that the luminaire is centered and that the ends of the mounting bars are parallel.
3. This is the most robust mounting method.

Tip: In some cases, you may find suitable threaded holes by removing the rubber feet from the luminaire base.

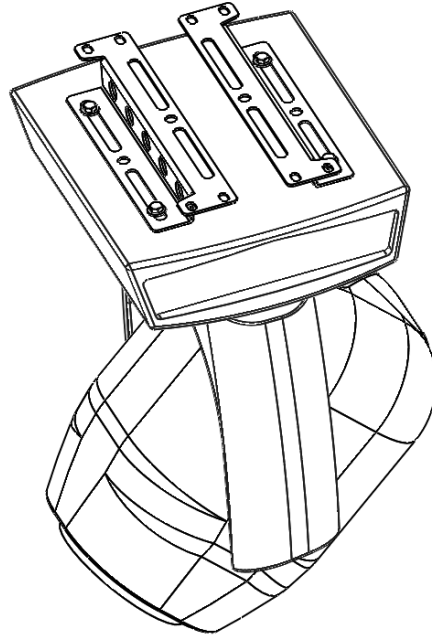

Quarter-Turn Fasteners (QTF)

Many luminaires with omega clamps do NOT have threaded mounting holes. In this case:

1. Use a hammer to knock out the steel pin from the omega clamp quarter-turn fasteners.
2. Remove the QTF from the omega clamp.

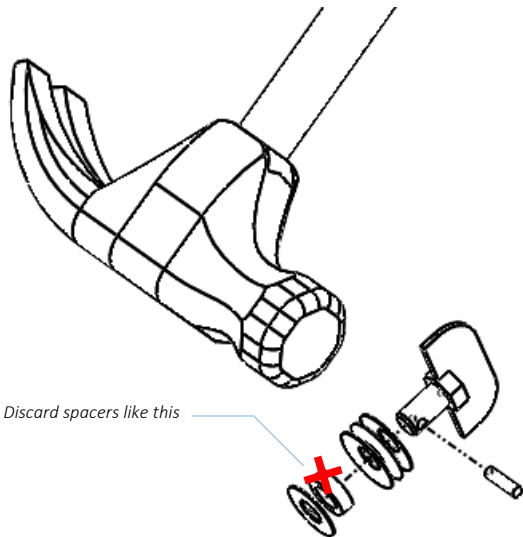

3. If there is a spacer on the QTF, remove and discard it
4. Re-assemble the QTF and replace the pin (tap home with a hammer)
5. Use the QTFs to fasten the mounting bars to the luminaire base.

TIP: If the QTFs are not tight, take them apart and add a flat washer to pack out the length.

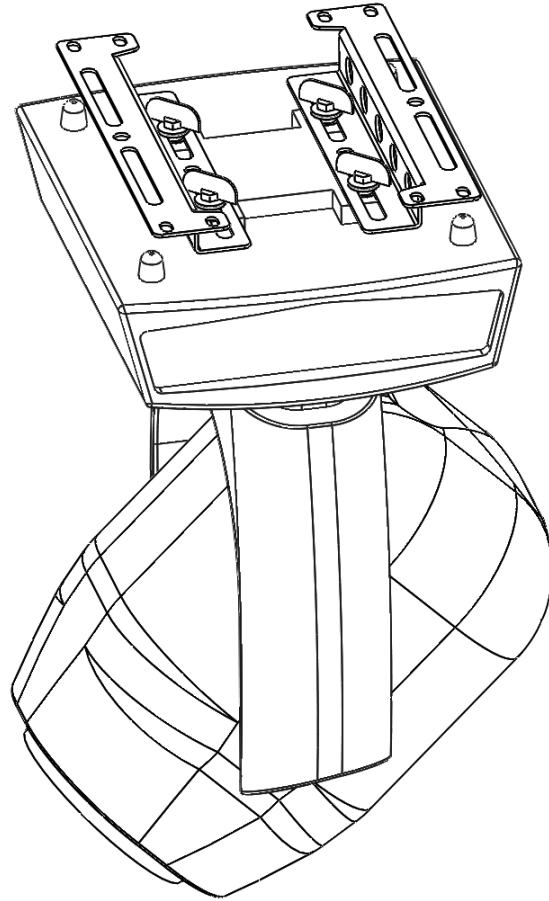

6. Re-assemble the QTF. NOTE: Some QTFs may have spacers that are too wide (>12.7mm/.5in) to fit the Tornado mounting slots. Discard these spacers.
7. Use the QTFs to secure the mounting bars to the luminaire base.

Check that the luminaire is centered and that the ends of the mounting bars are parallel.

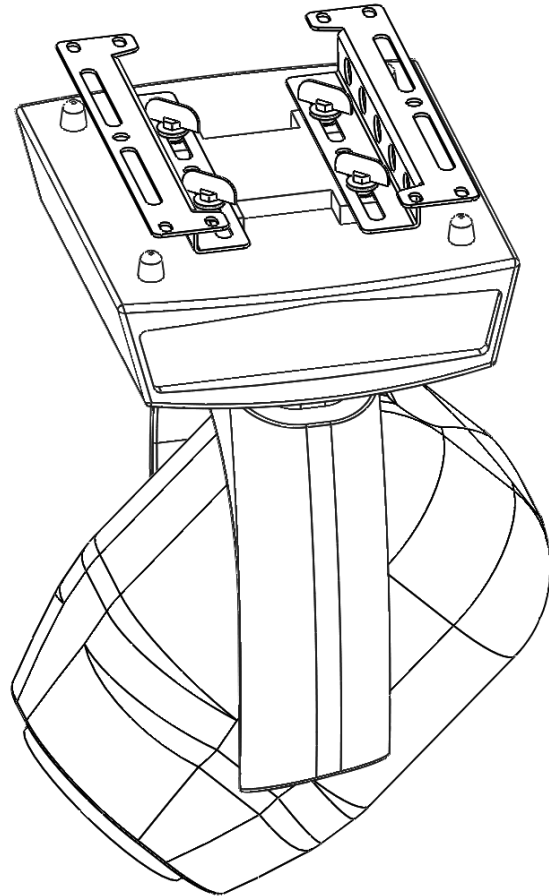

Install Luminaire in the Tornado Base

Now take the luminaire, with mounting bars, and install into the Tornado enclosure base, using the 8mm carriage bolts, washers and nuts you removed at the start of this process.

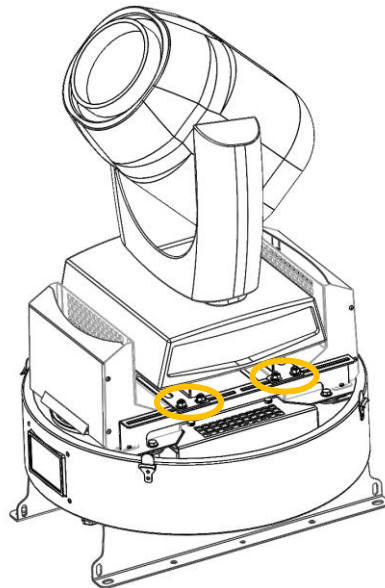

Vari-Lite Truss Adapters

Vari-Lite luminaires come with a pair of proprietary truss adapter brackets that snap onto 'buttons' on the base of the luminaire.

1. Snap the adapter brackets onto the luminaire buttons, following the manufacturer's instructions

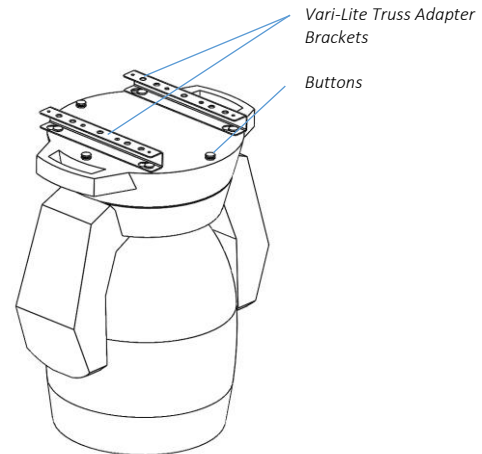

2. Bolt the luminaire mounting bars to the truss adapter brackets, using the M12 mounting hardware supplied
3. Replace the whole assembly in the Tornado base and secure with the 8mm carriage bolts supplied.

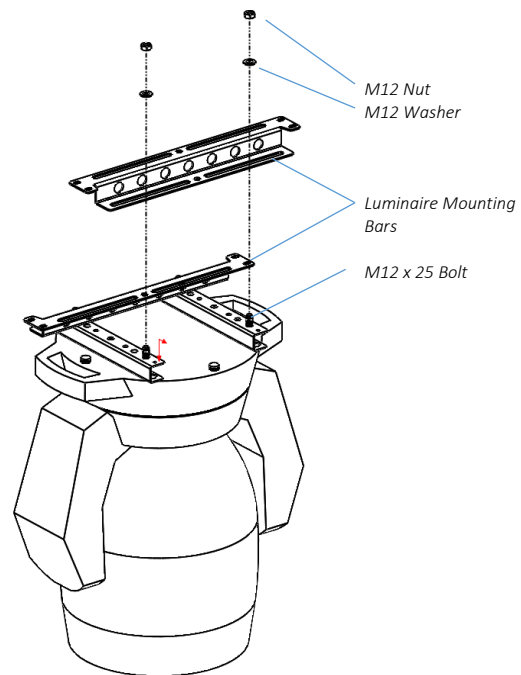

Connect Luminaire Power

1. Connect the luminaire power cable into the PowerCon True outlet provided
2. Connect luminaire control wiring, following manufacturer's instructions
3. Connect all cables and test luminaire

IMPORTANT:

YOU **MUST** CONNECT THE LUMINAIRE TO THE LUMINAIRE OUTLET. IF THE LUMINAIRE FEED BYPASSES THE DEC CONTROLLER, THE VENTILATION SYSTEM WILL NOT WORK AND THE LUMINAIRE WILL OVERHEAT.

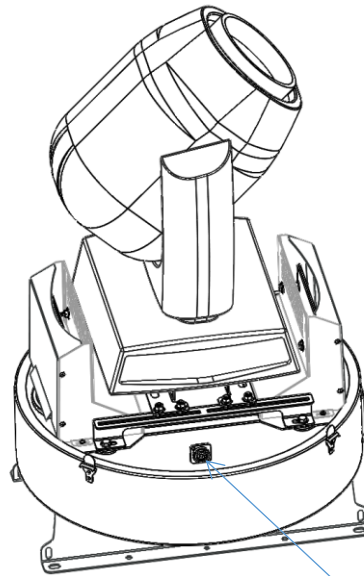

Neutrik PowerCon True
Outlet.
Use Neutrik PowerCon
True plug, item #
NAC3MX-W

Routine Maintenance

Maintenance schedules are very dependent on local conditions, and will vary significantly between installations, depending on:

- Climate type
- Air quality
- Usage patterns
- Enclosure type – Standard or Marine

Therefore, we recommend initially performing routine maintenance every three months, and adjusting the time intervals based on local experience. In many cases a six-month or twelve month cycle may be adequate.

Cleaning the Acrylic Globe

Clean Tornado globe using an acrylic cleaner/polish, window cleaning fluid or detergent. Use a soft, lint free cloth.

DO NOT USE AGGRESSIVE HYDROCARBON-BASED SOLVENTS SUCH AS GOO-GONE.



Cleaning Painted Parts

Use a mild detergent and a soft cloth or sponge to clean exposed painted metal parts



Use of Power Washers

It is acceptable to clean globe-up Tornado enclosures with a power washer from above.

DO NOT use a power washer jet to clean globe-down or horizontal Tornadoes from below. **This may cause water damage to the enclosure filters and electronics and will void the warranty.**

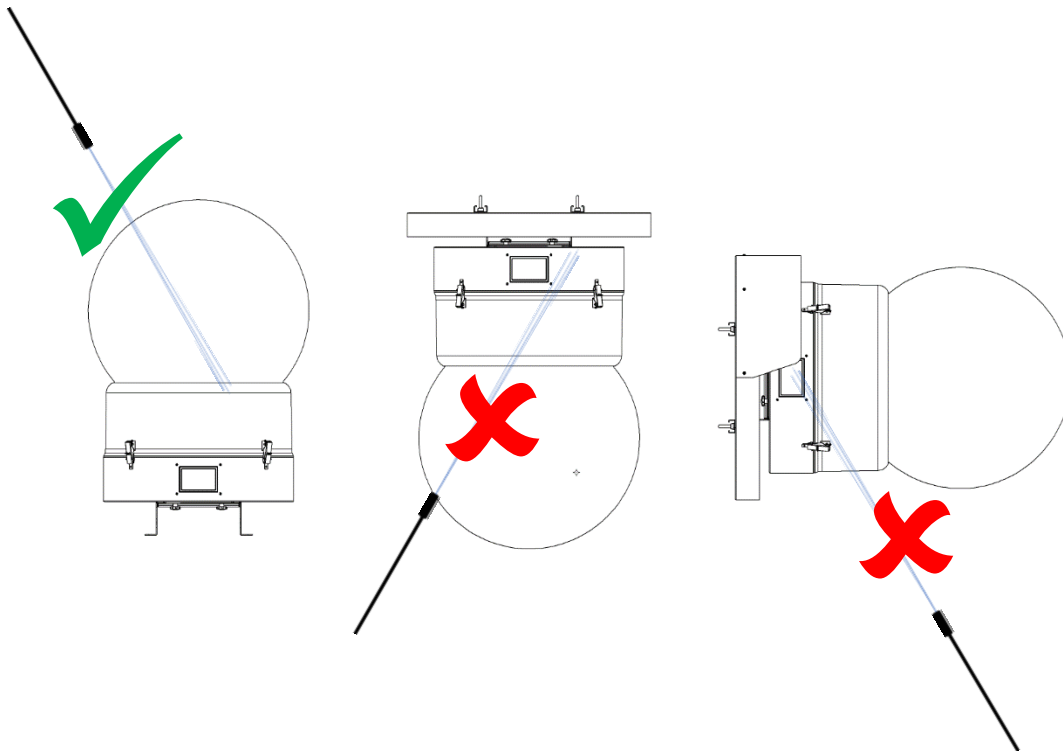

Check Inlet Filter

In most cases the inlet filter will be good for 1-2 years. If the filter becomes clogged the temperature inside the enclosure will start to rise. This is an indication that the filter must be changed.

If the inlet filter is compromised by being damaged, missing, or used beyond the end of its life, the equipment inside the enclosure may suffer damage, and will not be covered by Tempest's warranty.

Tornado Foam Inlet Filters may be washed, using water and mild detergent, and re-used.

Inlet Filter Part Numbers:

20.024.23	Tornado 1850-1975 Electrostatic Filter
21.022.23.HF	Tornado Marine 1850-1975 Salt Fog Filter
20.024.32	Tornado 2000-2300 Electrostatic Filter
21.022.32.HF	Tornado Marine 2000-2300 Salt Fog Filter
20.024.38	Tornado 2400-2500 Electrostatic Filter
21.022.38.HF	Tornado Marine 2400-2500 Salt Fog Filter

Tornado Marine Salt Fog Filters must be replaced when clogged or compromised.

To replace the inlet filter

1. Loosen the filter knobs on the back of the enclosure
2. Remove the filter knobs on the front of the enclosure (DEC User Interface side)
3. Slide out the filter Tray
4. Replace the filter (electrostatic foam filters may be washed with water and a mild detergent)
5. Replace the filter tray
6. Tighten all filter knobs

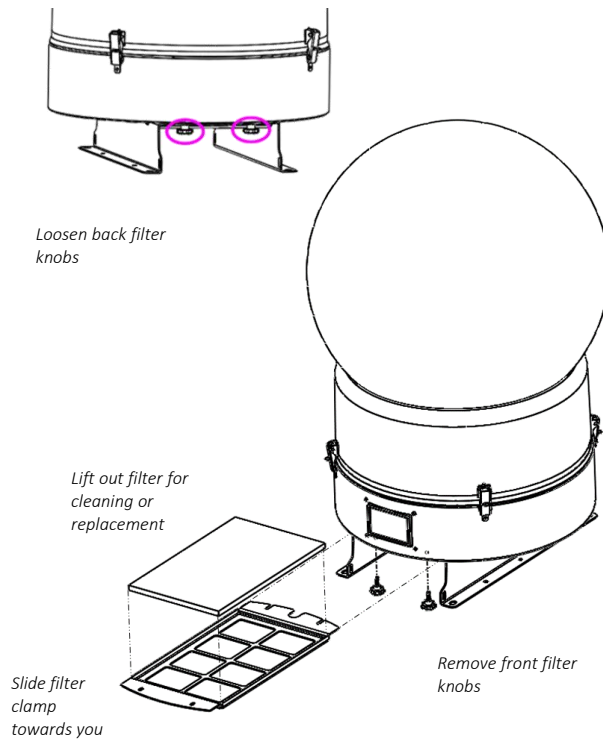

Exhaust Filters

The exhaust filters are located each side of the inlet filter. Examine by removing the enclosure globe assembly. Normally, exhaust filters should have a longer life than inlet filters.

Exhaust filters are primarily used to prevent large insects and wind-blown debris such as leaves from entering the enclosure.

Exhaust filters may be removed and cleaned using a hose pipe or running tap, with mild detergent if required.

Exhaust Filter Part Numbers

20.025.23L	Tornado 1850-1975 Exhaust Filter, Left
20.025.23R	Tornado 1850-1975 Exhaust Filter, Right
20.025.32L	Tornado 2000-2360 Exhaust Filter, Left
20.025.32R	Tornado 2000-2360 Exhaust Filter, Right
20.025.38L	Tornado 2400-2500 Exhaust Filter, Left
20.025.38R	Tornado 2400-2500 Exhaust Filter, Right

Each Tornado G4 enclosure requires one Left and one Right exhaust filter.

Check DEC Control Function

Power down the enclosure and remove the globe assembly.

Reconnect Power:

- a) When the DEC controller initializes correctly, you will hear a loud BEEP
- b) Fans will run for a few seconds. Place your hand above each airflow chimney to check airflow
- c) Heater will run long enough to become warm (but not hot).

If all three indications are good, the DEC and active components are in good working order.

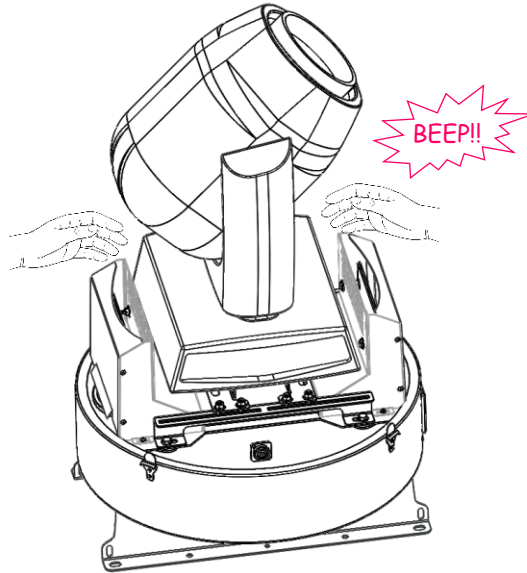

Check Temperature/Humidity Sensor

If the sensor above the DEC4 cover is defective, the controller may not operate correctly. A defective sensor will result in one of three messages appearing on the DEC user interface.

If you see any of these messages, contact Tempest for a replacement sensor.

RH: 5%
RH: 100%
RH: #####

For After Sales Support

Contact your Tempest dealer or email info@tempest.biz

Troubleshooting

Luminaire does not have power:

1. Check Luminaire power switch
2. Check luminaire is plugged into DEC4 luminaire outlet
3. Check that enclosure feed circuit is on
4. Check DEC4 User Interface leds are on. If feed circuit is on and UI leds are off, check feed wiring to DEC terminals and meter DEC4 luminaire outlet for power
5. If UI lamp led is on and DEC4 luminaire outlet is live, there is a luminaire fault.

Enclosure overheats:

1. **Is the luminaire connected to the DEC4 luminaire receptacle?** If the luminaire is powered independently the controller has no way to know when to turn on the exhaust fans!
2. Is the filter clogged or obstructed?
3. Check that the Fan led on the UI is on when the luminaire is running. If not, then the luminaire is probably not connected to the DEC (see 1).
4. If the fan led is on, check that the fan is running. If not, check fan wiring. If wiring is ok, fan may be faulty.
5. Check the UI display for RH (relative humidity) message. If display reads RH 5%, RH 100%, or RH###, there is a sensor fault. Contact Tempest for a replacement sensor.

Dirt/Debris inside enclosure

1. Filter is either missing or damaged?
2. Filter is not properly seated
3. Side panels or back door is not firmly latched

Water in enclosure

1. Check the drain holes in the bottom of the enclosure. If they become blocked, and water that gets in cannot escape.
2. Check seals around the globe and globe collar

Fan LED is on but fans do not operate

The exhaust fan is protected by a 20mm 4A slow-blow fuse on the DEC4 motherboard, and a secondary fuse on the fan board. In very exceptional cases it is possible that either fuse could fail. Check visually.

The fuse is protected with a clear resin sealant and soldered to the circuit board. With care, you can de-solder the fuse and replace it, but we recommend replacing the DEC4 motherboard to maintain the integrity of the board's conformal coating.

Heater LED is on but heater does not operate

The heater is protected by a 20mm 10A slow-blow fuse on the DEC4 motherboard. In very exceptional cases it is possible that it could fail. Check visually.

The fuse is protected with a clear resin sealant and soldered to the circuit board. With care, you can de-solder the fuse and replace it, but we recommend



None of the above?

replacing the DEC4 motherboard to maintain the integrity of the board's conformal coating.

Contact info@tempest.biz

Warranty

INSPECTION/WARRANTY/RETURNS.

A. Customer, at its sole expense, shall inspect all Goods promptly upon receipt and accept all Goods that conform to the specifications or catalog. All claims for any alleged defect in or failure of the Goods or Seller's performance to conform to the Contract, capable of discovery upon reasonable inspection, must be set forth in a written rejection notice detailing the alleged non-conformity, and be received by Seller within thirty (30) calendar days of Customer's receipt of the Goods. Failure by Customer to notify Seller of the alleged non-conformity within thirty (30) days will be conclusive proof that the Goods have been received by Customer without defects or damage, and in the quantities specified on the bill of lading and shall constitute an irrevocable acceptance of the Goods and a waiver of any such claim in connection with the Goods.

B. Seller warrants to Customer only that the Goods will be free from defects in material and workmanship at the time of delivery and, subject to the exceptions and conditions set forth below, for the following period (the "Warranty Period"): twelve (12) months from the date of shipment by Seller. Seller may provide additional years of warranty coverage beyond 12 months, at the rate of 2.5% of the net sale price per year, up to a total of four additional years' coverage beyond the standard 12 month warranty period. Seller will remedy a defect as set forth in paragraph 7 D, below, (the "Warranty"). The Warranty is subject to each of the following exceptions and conditions:

1. Customer must promptly (and in all events within the Warranty Period) notify Seller of any alleged defect in a written notice (the "Notice") which shall set forth the quantity, catalog number, finish, original purchase order number, Seller's invoice number on which Goods were originally billed and a statement of the alleged defect, along with digital photographs showing such defects where feasible.

2. The Warranty shall not apply: (i) to any claimed defect that was capable of discovery upon reasonable inspection and deemed to be waived under paragraph A, above; (ii) to any Goods that have been subject to misuse, abnormal service or handling, or altered or modified in design or construction; (iii) to any Goods repaired or serviced by any person other than Seller's authorized service personnel or to Goods installed other than according to installation instructions, or (iv) with respect to normal wear and tear.

3. Seller makes no Warranty with respect to parts or components that are not the product of Seller, and specifically makes no warranty whatsoever for equipment housed inside enclosure products manufactured by Seller.

4. The Warranty is Seller's exclusive warranty with respect to the Goods. Seller makes no warranties, guarantees or representations, express or implied, to Customer except as set forth in this section. ALL OTHER WARRANTIES, EXPRESS OR IMPLIED, INCLUDING, WITHOUT LIMITATION ANY IMPLIED WARRANTY OF MERCHANTABILITY OR OF FITNESS FOR USE OR FOR A PARTICULAR PURPOSE, ARE HEREBY EXCLUDED AND DISCLAIMED.

C. Seller will accept the return of Goods properly rejected under paragraph A, above, or as to which Notice of an alleged breach of Warranty has been timely given and such Goods may be returned to Seller, freight prepaid, but only upon Customer's receipt of Seller's written return material authorization ("RMA") and shipping instructions. The RMA shall be void if the Goods are not received within 45 days after issuance of the RMA. No deduction or credit in respect of any rejected or returned Goods shall be taken until Customer has received Seller's further written deduction or credit/authorization following Seller's inspection to confirm nonconformity or defect. Seller will charge to Customer any and all costs incurred by Seller in connection with the handling, shipping, inspection and disposition of any returned Goods that are determined by Seller not to have been nonconforming upon Delivery or as to which the warranty hereunder is not applicable.

D. UPON ANY PROPER RETURN PURSUANT TO PARAGRAPH C, ABOVE, WHETHER IN CONNECTION WITH A REJECTION OF GOODS OR AN ALLEGED BREACH OF WARRANTY AND BASED UPON THE CONDITIONS SET FORTH IN THIS PARAGRAPH 7, SELLER AGREES THAT IT WILL, AS THE SOLE AND EXCLUSIVE REMEDY UNDER THE CONTRACT OR OTHERWISE, FOR ANY NONCONFORMITY OR BREACH OF WARRANTY, AND AT SELLER'S SOLE ELECTION: (i) REPAIR SUCH GOODS; OR (ii) REPLACE SUCH GOODS.

Appendix – TEMP Protocol

AVAILABLE TO SPECIAL ORDER

Tempest can optionally provide a firmware load that facilitates TEMP over RS485, suitable for interfacing to an Ethernet adapter. TEMP is a lightweight proprietary ASCII based protocol, intended for rapid integration into management systems. With TEMP and a suitable RS485 to Ethernet adaptor connected to the DEC DMX connectors, your DEC may be configured and monitored over an IP network. Please contact factory for ordering information.

Physical Layer

1. EITHER: Use a 51.EN Ethernet daughter board plugged directly to the DEC4 motherboard, connected to your TCP/IP network.
2. OR: Use a 51.485 RS485 daughter board on each of a number of DEC4 motherboards, and use one of the convertors listed below to bridge to your TCP/IP network.

Suitable Converters include:

<http://gridconnect.com/rs485-ethernet.html>

<http://www.audon.co.uk/lan232/ENET485-POE.html>

<http://uk.rs-online.com/web/generalDisplay.html?id=brainboxes>

Developer's Guide

Download the Developer Guide from www.tempest.biz/tech-support.