

Rigging Points
- 4 x M12

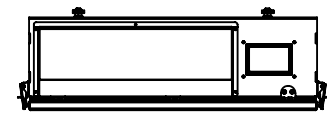

Inlet Cowl, Filters

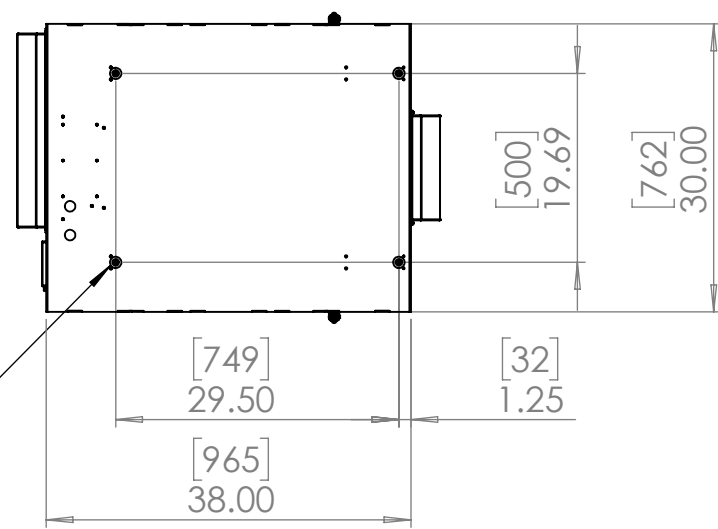
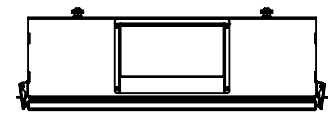
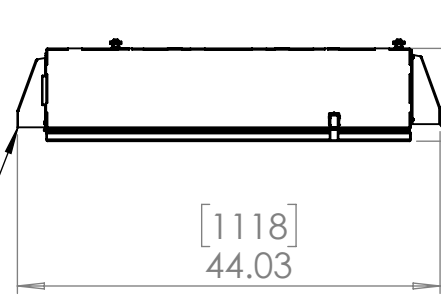

Exhaust Cowl, Insect Screen

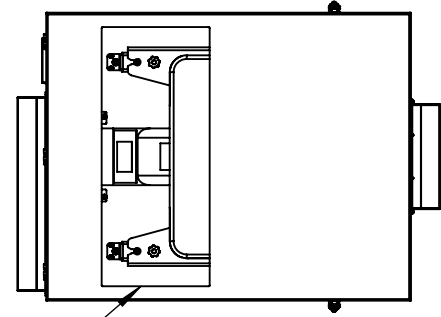

Tempered optical grade port glass

Note:
Enclosure is shown hanging, base-up, projecting downwards. It may also be installed base-down, projecting upwards, by inverting the inlet and exhaust cowls.

UNLESS OTHERWISE SPECIFIED:
DIMENSIONS ARE IN INCHES
TOLERANCES:
FRACTIONAL ±
ANGULAR: MACH ± BEND ±
TWO PLACE DECIMAL ±
THREE PLACE DECIMAL ±
INTERPRET GEOMETRIC TOLERANCING PER:
MATERIAL
Aluminum
FINISH
Powder Coat Lt Bronze
DO NOT SCALE DRAWING

	NAME	DATE
DRAWN	TB	8/3/2017
CHECKED		
ENG APPR.		
MFG APPR.		
Q.A.		
COMMENTS:		



TITLE: Blizzard 100 UST		
SIZE B	DWG. NO. 52.100.UST	REV 02
SCALE: 1:50		SHEET 1 OF 3

8 7 6 5 4 3 2 1

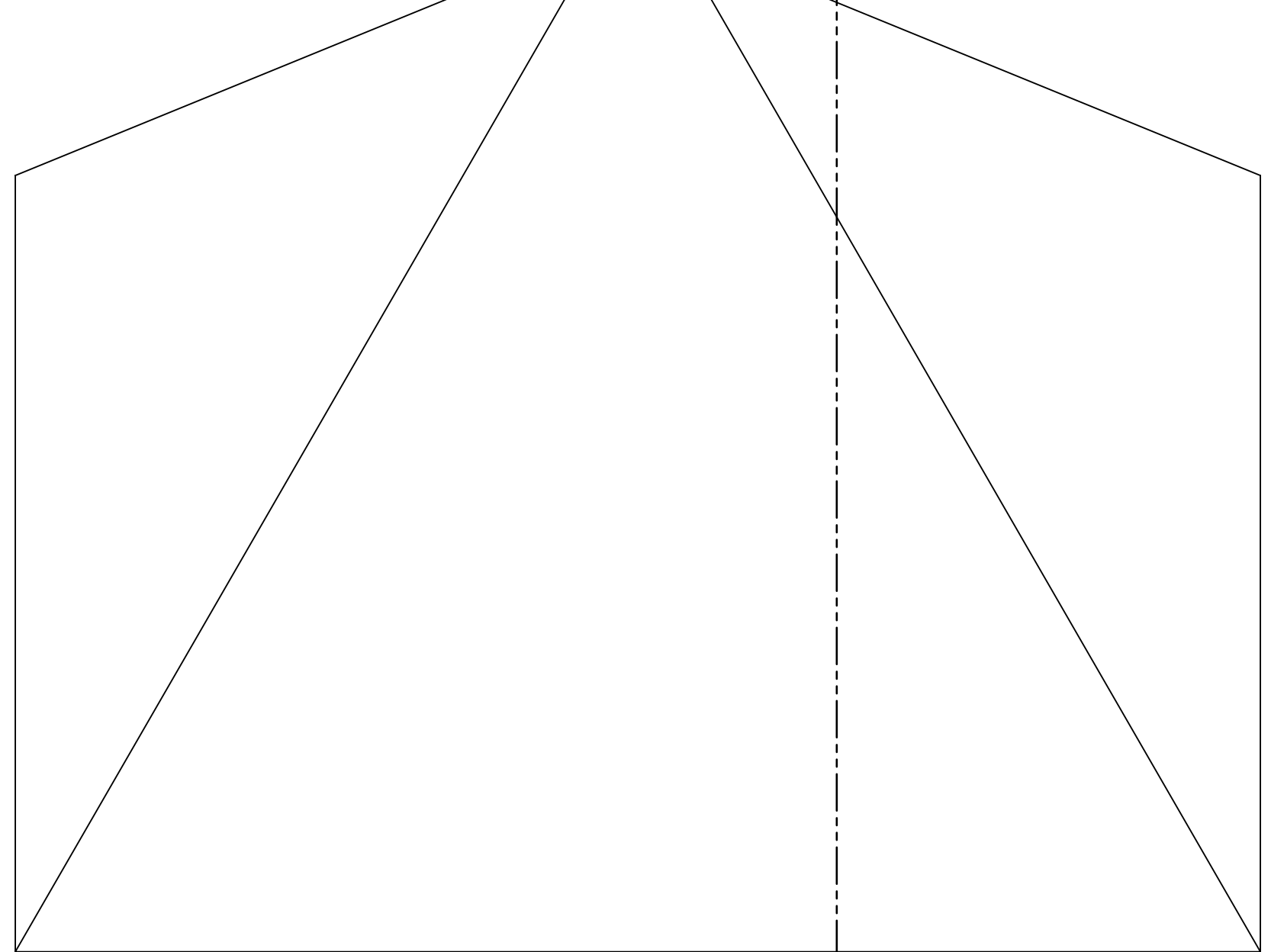
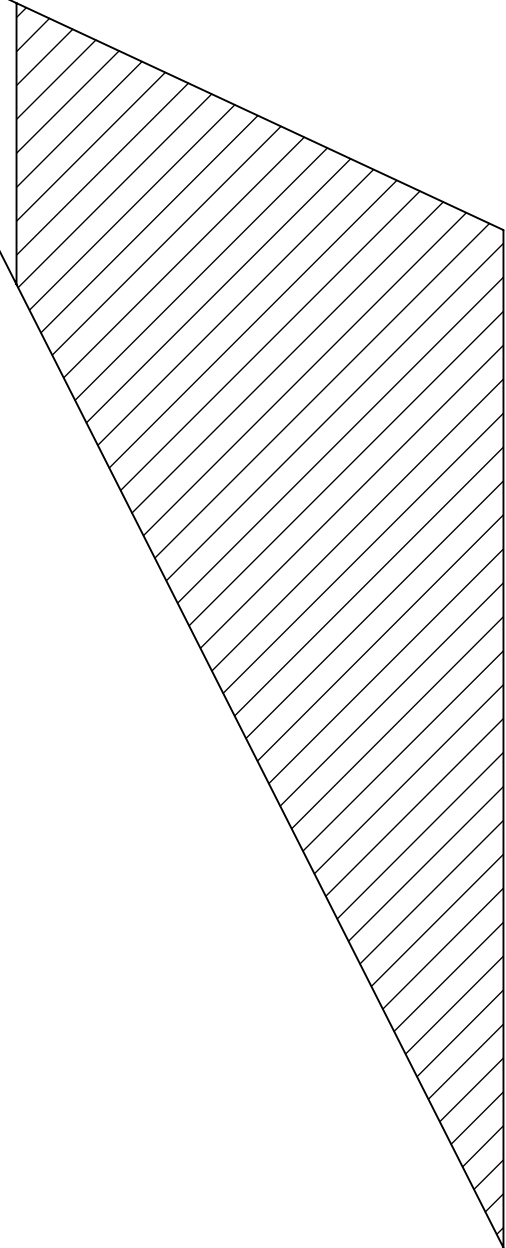
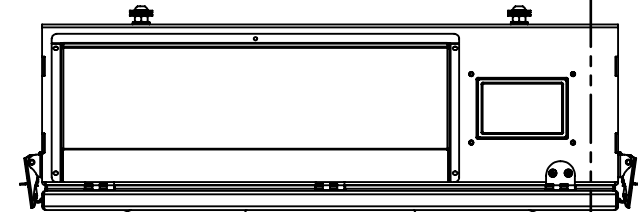
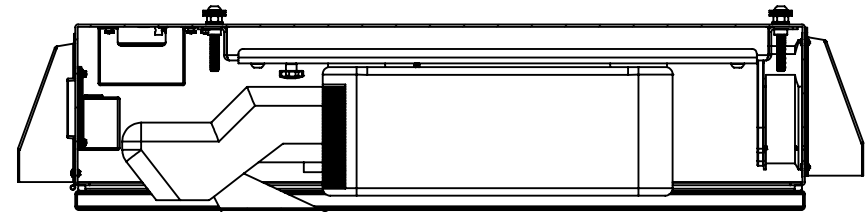

SECTION C-C
SCALE 1:10

UNLESS OTHERWISE SPECIFIED:
DIMENSIONS ARE IN INCHES
TOLERANCES:
FRACTIONAL ±
ANGULAR: MACH ± BEND ±
TWO PLACE DECIMAL ±
THREE PLACE DECIMAL ±
INTERPRET GEOMETRIC TOLERANCING PER:
MATERIAL
Aluminum
FINISH
Powder Coat Lt Bronze
DO NOT SCALE DRAWING

	NAME	DATE
DRAWN	TB	8/3/2017
CHECKED	←	
ENG APPR.	C	
MFG APPR.		
Q.A.		
COMMENTS:		



TEMPEST
lighting inc.

TITLE: Blizzard 100 UST

SIZE	DWG. NO.	REV
B	52.100.UST	02

SCALE: 1:50 SHEET 2 OF 3

8 7 6 5 4 3 2 1

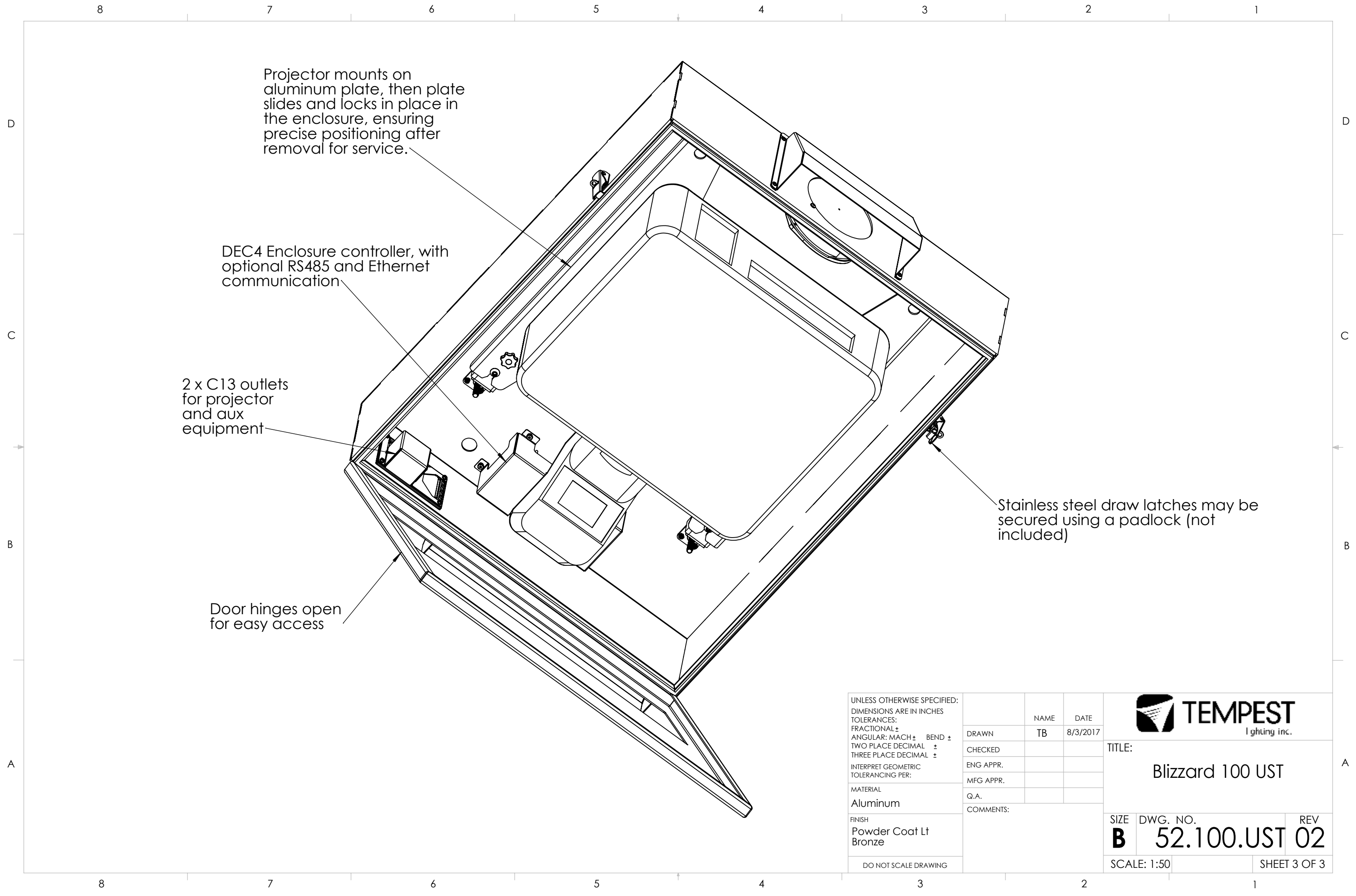

UNLESS OTHERWISE SPECIFIED:
 DIMENSIONS ARE IN INCHES
 TOLERANCES:
 FRACTIONAL ±
 ANGULAR: MACH ± BEND ±
 TWO PLACE DECIMAL ±
 THREE PLACE DECIMAL ±
 INTERPRET GEOMETRIC TOLERANCING PER:
 MATERIAL
 Aluminum
 FINISH
 Powder Coat Lt Bronze
 DO NOT SCALE DRAWING

	NAME	DATE
DRAWN	TB	8/3/2017
CHECKED		
ENG APPR.		
MFG APPR.		
Q.A.		
COMMENTS:		



TITLE: Blizzard 100 UST		
SIZE B	DWG. NO. 52.100.UST	REV 02
SCALE: 1:50		SHEET 3 OF 3